

PREPARED BY AND TO BE RETURNED TO:
LOUIS D. ZARETSKY, ESQ.
RITTER, ZARETSKY & LIEBER, LLP
555 NE 15TH STREET #100
MIAMI, FLORIDA 33132

**DECLARATION OF CONDOMINIUM
FOR
GARDENS OF BRIDGEHAMPTON, A CONDOMINIUM**

Section 1: Introduction and Submission.....	1
Section 2: Definitions	1
Section 3: Description of Condominium.....	2
Section 4: Restraint upon Separation and Partition of Common Elements.....	6
Section 5: Ownership of Common Elements and Common Surplus and Share of Common Expenses; Voting Rights	7
Section 6: Amendments.....	7
Section 7: Maintenance and Repairs	8
Section 8: Additions, Alterations or Improvements by the Association	9
Section 9: Additions, Alterations or Improvements by Unit Owner.....	9
Section 10: Additions, Alterations or Improvements by Developer	10
Section 11: Operation of the Condominium by the Association; Powers and Duties	10
Section 12: Management Agreement.....	12
Section 13: Determination of Assessments	12
Section 14: Collection of Assessments	13
Section 15: Insurance	14
Section 16: Reconstruction or Repair After Fire or Other Casualty.....	16
Section 17: Condemnation.....	17
Section 18: Occupancy and Use Restrictions	18
Section 19: Selling, Leasing and Mortgaging of Units.....	20
Section 20: Compliance and Default.....	20
Section 21: Termination of Condominium	21
Section 22: Additional Rights of Mortgagees and Others.....	21
Section 23: Disclaimer of Warranties	22
Section 24: Arbitration.....	23
Section 25: Additional Provisions.....	23

132 pgs.

Gardens of Bridgehampton LLC, a Delaware limited liability company, hereby declares as follows:

Section 1: Introduction and Submission

1.1 The Land. The Developer owns the fee title to certain land together with improvements thereon located in Duval County, Florida, as more particularly described in Exhibit "A" hereto (the "Land").

1.2 Submission Statement. The Developer hereby submits the Land together with all improvements from time to time erected or to be installed thereon to the condominium form of ownership and use in the manner provided for in the Florida Condominium Act as it exists on the date hereof, subject to the reservations, easements and restrictions of record.

1.3 Property Subject to Certain Restrictions and Easements. The Condominium Property (as defined hereinafter) is subject to the covenants, conditions, restrictions, easements and reserved rights of the Developer contained in this Declaration.

1.4 Name. The name by which this condominium is to be identified is GARDENS OF BRIDGEHAMPTON, A CONDOMINIUM (the "Condominium").

Section 2: Definitions

For purposes of this Declaration and the exhibits attached hereto, the following terms shall have the respective meanings ascribed to them in this Section, except where the context clearly indicates a different meaning or a specific limited meaning is detailed:

2.1 "Act" or "Condominium Act" or "Florida Condominium Act" means the Florida Condominium Act (Chapter 718, Florida Statutes) as it exists on the date hereof.

2.2 "Articles" or "Articles of Incorporation" means the Articles of Incorporation of the Association, as may be amended from time to time. A certified copy of the original Articles of Incorporation are attached hereto as Exhibit "B".

2.3 "Assessment," as further described and defined in Sections [13] and [14] hereof, means a share of the funds required for the payment of Common Expenses as provided in this Declaration and which from time to time is assessed against the Unit Owner.

2.4 "Association" or "Condominium Association" means GARDENS OF BRIDGEHAMPTON CONDOMINIUM ASSOCIATION, INC., a Florida corporation not-for-profit, the sole entity responsible for the operation of the Condominium. Where utilized herein or in the exhibits attached hereto, the term "Corporation" shall be deemed to be synonymous with the term "Association."

2.5 "Association Property" means the property, real and personal, in which title or ownership is vested in, or which is dedicated on a recorded plat or leased to, the Association for the use and benefit of its members.

2.6 "Buildings" means the structures within which the Units and certain Common Elements are located on the Condominium Property.

2.7 "Board of Directors" or "Board" means the Board of Directors of the Association.

2.8 "By-Laws" mean the By-Laws of the Association, as may be amended from time to time. A copy of the original By-Laws are attached hereto as Exhibit "C".

2.9 "Common Elements" mean and include:

- (a) The portions of the Condominium Property which are not included within the Units;
- (b) Easements over, under, across, and through Units for conduits, ducts, plumbing, wiring and other facilities for the furnishing of utility and other services to the Units and the Common Elements;
- (c) An easement of support in every portion of a Unit which contributes to the support of any other Unit or the Buildings;
- (d) The property and installations required for the furnishing of utilities and other services to more than one Unit or to the Common Elements;
- (e) Any hallways, foyers, doors, elevators, stairwells, alarm systems, access systems, or security systems not contained within a specific Unit;
- (f) All pipes, lines, wiring, facilities and conduits located within the walls which bound and are contained within a Unit and which provide services to more than one Unit; and
- (g) Any other parts of the Condominium Property designated as Common Elements pursuant to this Declaration or the Act.

2.10 "Common Expenses" mean all expenses incurred by the Association to accomplish its duties as contemplated by the Act, this Declaration the Articles or the Bylaws and which shall be assessed or imposed against Units in the Condominium by the Association as authorized by the Act. If approved by the Board of Directors, "Common Expenses" shall include the cost of mangrove trimming and the cost of a master television antenna system

or duly franchised cable television service obtained pursuant to a bulk contract or other provider on a bulk basis (as distinguished from any equipment or services which may be installed within or adjacent to or provided to any of the Commercial Units as elsewhere provided herein) . For all purposes of this Declaration, "Common Expenses" shall also include all reserves required by the Act or otherwise established by the Association, regardless of when reserve funds are expended. References herein to Common Expenses also shall include Residential Limited Common Expenses unless the context would prohibit or it is otherwise expressly provided.

2.15 "Common Surplus" means the excess of all receipts of the Association collected on behalf of the Association, including, but not limited to, Assessments, rents, profits and revenues on account of the Common Elements, over and above the amount of Common Expenses.

2.16 "Condominium Parcel" means a Unit together with the undivided share in the Common Elements and the Common Surplus which is appurtenant to said Unit.

2.17 "Condominium Plat" means the condominium drawings required by Section 718.104 of the Act and recorded in the Condominium Book and Page identified on the first (1st) page hereof constituting Exhibit "A" hereto. For purpose of reference, a reduced-in-size copy of the Condominium Plat is attached hereto.

2.18 "Condominium Property" means the Land and the improvements constructed thereon which have been submitted to condominium ownership under this Declaration, subject to the limitations thereof and exclusions therefrom.

2.19 "County" means Duval County, State of Florida.

2.20 "Declaration" or "Declaration of Condominium" means this instrument, as it may be amended from time to time.

2.21 "Developer" means Gardens of Bridgehampton LLC, a Delaware limited liability company, and its successors and such of its assigns as to which its rights hereunder are assigned by written instrument recorded in the public records of the County. Such assignment may be made on an exclusive or non-exclusive basis and may be an assignment of all or only portions of its rights of Developer hereunder; provided, however, that no such assignment shall make any assignee the "Developer" for purposes hereof unless such assignment is an assignment of all of Developer's rights hereunder and is exclusive, except as to any previously assigned rights.

2.22 "Institutional First Mortgagee" means a bank, savings and loan association, insurance company, credit union, real estate or mortgage investment trust, pension fund, an agency of the United States Government, mortgage banker, the Federal National Mortgage Association ("FNMA"), the Federal Home Loan Mortgage Corporation ("FHLMC") or any other lender generally recognized as an institutional lender, or the Developer, holding a first mortgage on a Unit or Units. A "Majority of Institutional First Mortgagees" shall mean and refer to Institutional First Mortgagee(s) of Units with regard to at least 51% of the voting interests which are appurtenant to Units subject to mortgages held by Institutional First Mortgagees.

2.24 "Limited Common Elements" mean those Common Elements, the use of which is reserved to a certain Unit or Units to the exclusion of other Units, as same are shown on the Condominium Plat or are specified in this Declaration. References herein to Common Elements also shall include all Limited Common Elements unless the context would prohibit or it is otherwise expressly provided.

2.25 "Management Agreement" means and refers to any agreement entered into by the Association from time to time for the operation and administration of the Condominium and the management of the Condominium Property.

2.26 "Occupant" means and refers to a person (be it an Owner or a tenant or lessee of an Owner) who resides in a Unit. Where the context dictates, an Occupant shall also be deemed to include the family members, occasional social guests, tenants, licensees and invitees.

2.27 "Primary Institutional First Mortgagee" means the Institutional First Mortgagee which owns, at the relevant time, Unit mortgages securing a greater aggregate indebtedness than is owed to any other Institutional First Mortgagee.

2.30 "Residential Unit" means each of the Units other than Commercial Units. References herein to Units or Parcels shall include Residential Units unless the context prohibits or it is otherwise expressly provided.

2.31 "Unit" or "Condominium Unit" means and refers to that portion of the Condominium Property which is subject to exclusive ownership and is located within the Condominium Property.

2.32 "Unit Owner" or "Owner of a Unit" or "Owner" means the record owner of legal title to a Condominium Unit.

Section 3: Description of Condominium

3.1 Identification of Units. The Condominium shall contain three hundred fifty-two (352) Residential Units.

Each such Unit is identified by a separate numerical or alpha-numerical designation as shown on the Condominium Plat, which exists as Exhibit "A" hereto, and which consists of a survey of the Land, a graphic description of the improvements located thereon (including the Units and the Buildings in which the Units are located), and a plot plan thereof. A reduced-in-size copy of the Condominium Plat as recorded in the Condominium Book and Page identified on the first (1st) page hereof, together with a copy of the legal description contained on the Condominium Plat, is attached to this Declaration for convenience. The Condominium Plat, together with this Declaration, is sufficient in detail to identify the Common Elements and each Unit and their relative locations and dimensions. There shall pass with a Unit as appurtenances thereto: (a) an undivided share in the Common Elements

and Common Surplus; (b) the exclusive right to use such portion of the Common Elements as may be the Limited Common Elements for such Unit; (c) an exclusive easement for the use of the air space occupied by the Unit as it exists at any particular time and as the Unit may lawfully be altered or reconstructed from time to time, provided that an easement in air space which is vacated shall be terminated automatically; (d) membership in the Association with the full voting rights appurtenant thereto; and (e) other appurtenances as may be provided by this Declaration or the Act.

Timeshare estates or interests will not be created with respect to any of the Units in the Condominium.

3.2 Unit Boundaries. Each Unit shall include that part of the Buildings containing the Unit that lies within the following boundaries:

(a) All Units.

(i) Upper and Lower Boundaries of Living Space. The upper and lower boundaries of each Unit shall be the following boundaries extended to their planar intersections with the perimetrical boundaries:

(1) Upper Boundaries of Living Space. The horizontal plane of the unfinished lower surface of the ceiling.

(2) Lower Boundaries of Living Space. The horizontal plane of the unfinished upper surface of the floor of the Unit.

(3) Interior Divisions of Living Space. Except as provided in subsections (1) and (2) above, no part of the floor of the top floor, ceiling of the bottom floor, stairwell adjoining the two-floors or nonstructural exterior walls shall be considered a boundary of the Unit.

(ii) Perimetrical Boundaries. The perimetrical boundaries of the Residential Unit shall be the vertical planes of the unfinished interior surfaces of the walls bounding the Unit and the centerline of the partitioning walls between units extended to their planar intersections with each other and with the upper and lower boundaries.

(iii) Apertures. Where there are apertures in any boundary, including, but not limited to, windows, bay windows, doors, skylights, balconies and porches, such boundaries shall be extended to include the windows, bay windows, doors, skylights and other fixtures located in such apertures, including all frameworks thereof; provided, however, that exterior surfaces made of glass or other transparent material and the exteriors of doors shall not be included in the boundaries of the Unit and shall therefore be Common Elements.

Notwithstanding the fact that no Unit may be divided or partitioned for purposes of sale or lease, a Unit may be combined with either the Unit directly above the subject Unit and/or the Unit directly below the subject Unit and/or the laterally-adjacent Unit in order to permit occupancy of such areas as one residential living space. In the event two (2) or more Units are combined there shall be no change the proportion or percentage by which the Unit Owner shares the Common Expenses and owns the Common Surplus. All assessments and voting rights shall be calculated as if such units were as originally designated on the exhibits attached to the Declaration, notwithstanding the fact that two (2) or more Units have been combined.

3.3 Limited Common Elements.

Limited Common Elements Appurtenant to All Units. To the extent applicable and subject to the provisions of this Declaration, each Unit may have as Limited Common Elements appurtenant thereto such portions of the Common Elements as are defined herein and/or shown on the Condominium Plat, including, but not limited to:

- (a) any portion(s) of the Common Elements, including, but not limited to, conduits, ducts, plumbing, wiring and other facilities, for the furnishing of utility and other services to a particular Unit shall be a Limited Common Element appurtenant to that Unit;
- (b) the mailbox assigned to a particular Unit which shall be located within the Condominium Property;
- (c) any entrance stairway and all improvements thereto as to which direct and exclusive access shall be afforded to any particular Unit or Units to the exclusion of others;
- (d) light and electrical fixtures outside the Unit or attached to the exterior walls of the Unit and which solely serve such Unit. The use and enjoyment of the Limited Common Elements shall be in accordance with the terms and provisions of this Declaration, the Articles of Incorporation, the By-Laws, any rules and regulations duly promulgated by the Association, and local, state, and federal statutes and ordinances.
- (e) Balconies and Terraces. Balconies and terraces abutting a Unit shall be for the exclusive use of the Unit Owner owning such abutting Unit. The Unit Owner shall be responsible for the maintenance and care of the balcony or terrace. A Unit Owner shall not enclose the exterior balconies or terraces without the prior written approval of the Board of Administration.
- (f) Parking. Parking is restricted to the parking spaces located in the garages and parking areas or spaces noted on the survey attached as Exhibit "A" hereto. The Developer, for so long as it owns any Unit for sale, reserves the exclusive right to assign to any Unit the exclusive use of one or more parking spaces. At such time that the Developer no longer has the right to assign any parking spaces, the remaining parking spaces, may be assigned by the Association. Two parking spaces shall be assigned to each Unit as of the date of closing for title to each Unit for the exclusive use of the Unit Owner. All

assignments of parking spaces shall be by separate written assignment which will indicate that it is made under this subsection, but it may not be recorded among the Public Records. So long as each Unit shall have one parking space appurtenant thereto at all times, a Unit Owner who has acquired additional parking spaces from the Developer or Association, shall have the right to transfer or assign the exclusive use to such additional space or spaces to another Unit Owner. By acquiring title to or taking possession of a Unit, or accepting assignment of a parking space and/or parking garage, each owner expressly assumes any responsibility for loss damage or liability resulting therefrom.

- (g) Those areas designated as Limited Common Elements which are on Sheets of Exhibit "A" attached hereto are not as yet assigned to any particular Unit. Developer reserves the right to assign those Limited Common Elements to individual Unit Owners for compensation. The Limited Common Elements designated on these Sheets of Exhibit "A" attached thereto may be used for any permissible use, including, but not limited to, space as a commercial/display/storage area or for any other lawful purpose as determined in Developer's sole discretion. Assignment of these areas will be in writing and may be recorded upon the public records.

Responsibilities of Unit Owners. Except as may be otherwise provided in this Section 3.3, all maintenance, repairs, replacements and reconstructions of, in or to any Limited Common Elements, whether structural or nonstructural, ordinary or extraordinary (including, without limitation, maintenance, repair, replacement and reconstruction of any exterior wall or railing of balcony patio) shall be performed by the Association, except as otherwise expressly provided to the contrary herein. Each Unit Owner shall be responsible for replacing the necessary light bulbs for the foregoing light fixture(s) with the same color and bulb wattage. Each Unit Owner shall be solely responsible for maintaining all portions of the security system serving the Unit, including, without limitation, all electrical lines and other facilities. Each Unit Owner shall also be solely responsible for any costs associated with false alarms and all annual licensing or registration of alarms. Except as may be otherwise provided in this Section 3.3, all maintenance, repairs, replacements and reconstructions of, in or to any Limited Common Elements, whether structural or nonstructural, ordinary or extraordinary (including, without limitation, maintenance, repair, replacement and reconstruction of any exterior wall or railing of balcony patio) shall be performed by the Association, except as otherwise expressly provided to the contrary herein. Each Unit Owner shall be responsible for replacing the necessary light bulbs for the foregoing light fixture(s) with the same color and bulb wattage. Each Unit Owner shall be responsible for the air-conditioning compressor contained within the limited Common Elements serving and providing service to such Unit Owner's unit. Each Unit Owner shall be solely responsible for maintaining all portions of the security system serving the Unit, including, without limitation, all electrical lines and other facilities. Each Unit Owner shall also be solely responsible for any costs associated with false alarms and all annual licensing or registration of alarms. The Association shall be responsible for the maintenance, repair, replacements and reconstruction, of parking spaces.

3.4 Easements. The following easements are hereby created (in addition to any easements created under the Act and any other provisions of this Declaration):

(a) Support. Each Unit shall have an easement of support and of necessity and shall be subject to an easement of support and necessity in favor of all other Units and the Common Elements.

(b) Utility and Other Services; Drainage. Non-exclusive easements are hereby reserved unto the Developer and also granted to the respective utility providers under, through and over the Condominium Property as may be required from time to time for the construction, use and maintenance of all utilities (whether public or private), cable television, communications and security systems, and other services which may serve the Condominium; provided, however, that these easements shall not permanently interfere with the residential use of the Units. A non-exclusive easement is also reserved unto the Developer and granted to all applicable governmental entities over and across the Common Elements for the purpose of providing drainage and for the installation, operation, use and maintenance of drainage facilities; provided, however, that the Association shall be responsible for the continuous maintenance of the easements and rights-of-way of the drainage system located on any and all portions of the Condominium Property.

(c) Encroachments. If: (a) any portion of the Common Elements encroaches upon any Unit; (b) any Unit encroaches upon any other Unit or upon any portion of the Common Elements; or (c) any encroachment shall hereafter occur as a result of (i) construction of the improvements; (ii) settling or shifting of the improvements; (iii) any alteration or repair to the Common Elements made by or with the consent of the Association or the Developer, as appropriate, or (iv) any repair or restoration of the improvements (or any portion thereof) or any Unit after damage by fire or other casualty or any taking by condemnation or eminent domain proceedings of all or any portion of any Unit or the Common Elements; then, in any such event, a valid easement shall exist for such encroachment and for the maintenance of the same so long as the improvements shall stand.

(d) Ingress and Egress. A non-exclusive easement in favor of each Unit Owner and resident, their guests and invitees, shall exist for pedestrian traffic over, through and across sidewalks, streets, paths, walks, and other portions of the Common Elements as from time to time may be intended and designated for such purpose and use and for vehicular and pedestrian traffic over, through and across such portions of the Common Elements as from time to time may be paved and intended for such purposes. None of the easements specified in this subsection shall be encumbered by any leasehold or lien other than those on the Condominium Parcels. Any such lien encumbering such easements (other than those on Condominium Parcels) automatically shall be subordinate to the rights of Unit Owners and the Association with respect to such easements.

(e) Construction; Maintenance. The Developer (including its designees, contractors, successors and assigns) shall have the right, in its (and their) sole discretion from time to time, to enter the Condominium Property and take all other action necessary or convenient for the purpose of completing the construction thereof, or any part thereof, or any improvements or Units located or to be located thereon, and for repair, replacement and maintenance purposes or where the Developer, in its sole discretion, determines that it is required or desires to do so.

(f) Sales and Management Activities. Until such time as the Developer no longer offers condominium parcels for sale or lease in the ordinary course of business, the Developer, its designees, successors

and assigns, shall have the right to use any such Units and parts of the Common Elements for Unit models; sales, management and construction offices; to show model Units and the Common Elements to prospective purchasers and, if applicable, tenants of Units; and to erect on the Condominium Property signs and other promotional material to advertise Units for sale or lease. In addition, until such time as the Developer has conveyed all Units to third parties, the Developer shall be required to permit the Management Firm to utilize an office located within the Buildings in order to perform the services required of it pursuant to the management agreement, and the management agreement shall specifically authorize the Management Firm to utilize the Common Elements as may be necessary for the performance of the Management Firm's duties under the management agreement (provided that such usage does not interfere with the residential use of the Condominium Property).

(g) Facilities and Services. Easements over, under, across and through Units for conduits, ducts, plumbing, wiring and other facilities for the furnishing of utility and other services to the Units and the Common Elements.

(h) Condominium Plat. All easements described or shown on the Condominium Plat.

(i) Developer Activities. Until such time as the Developer completes and no longer offers condominium parcels for sale or lease in the ordinary course of business, the Developer reserves the right to prohibit access to any portion of the Common Elements of the Condominium Property or uncompleted Units to any of the Occupants of the Condominium, and to utilize various portions of the Common Elements or the Units in connection with such construction and development. No Unit Owner or such Owner's guests or invitees shall in any way interfere or hamper the Developer, its employees, successors or assigns, in connection with such construction. Thereafter, during such time as the Developer, its successors or assigns, own any Units within the Buildings and is carrying on any business in connection therewith, including the selling, renting or leasing of such Units, the Unit Owners, their guests and invitees shall in no way interfere with such activities or prevent access to such Units by the Developer, its employees, its successors or assigns.

(j) Association Easement. A perpetual, non-exclusive easement is hereby granted to the Association and its successors and assigns over, across, under and through the Condominium Property for the purpose of permitting the Association to perform its obligations hereunder. Such easement shall permit access to the Units upon reasonable prior notice, except that no notice shall be required in the event of an emergency.

(k) Cable Television. The Developer reserves unto itself, its successors, assigns, contractors, designees and nominees, (i) ownership of any closed circuit, master antenna, community antenna or cable television system or the like (including any and all related conduits, wires, amplifiers, antennas, towers and other apparatus and equipment) which it (or one of its successors, assigns, designees or nominees) installs in part or whole on the Condominium Property (any such system and its related apparatus and equipment being hereinafter referred to as the "CATV System", (ii) a perpetual easement over, through and across the Condominium Property for the installation, servicing, maintenance, repair, replacement and removal of the CATV System or any part thereof, (iii) the right to connect the CATV System to whatever receiving source the owner of the CATV System deems appropriate, and (iv) the right to provide (or cause to be provided) mandatory or non-mandatory services to Units through the CATV System (and related, ancillary services to Units, including, but not limited to, security-related services) at charges not to exceed those normally paid for like services by residents or single family homes or condominium units within the general vicinity of the Condominium, and to retain or assign all such charges.

(l) Special Telephone Services. Telephone service shall be provided by Bell South. Bell South, its successors, assigns, contractors, designees and nominees, shall retain: (i) ownership of any telephone system (including any and all related conduits, wires and other apparatus and equipment) which it (or one of its successors, assigns, designees or nominees) installs in part or whole on the Condominium Property (any such system and its related apparatus and equipment being hereinafter referred to as the "Telephone System"), (ii) a perpetual easement over, through and across the Condominium Property for the installation, servicing, maintenance, repair, replacement and removal of the Telephone System or any part thereof, and (iii) the right to provide (or cause to be provided) mandatory or non-mandatory services to Units through the Telephone System (and related ancillary services), and to retain or assign the charges collected from Owners therefor.

A Unit Owner shall do nothing within or outside his Unit that interferes with or impairs, or may interfere with or impair, the provision of such utility, cable television, communications and security systems, or other service or drainage facilities or the use of these easements. The Association shall have the irrevocable right of access to each Unit during reasonable hours, when necessary, to maintain, repair or replace those items and areas, as detailed in Section 7.1 herein or as otherwise contemplated herein, for which the Association is responsible, and to remove any improvements interfering with or impairing such facilities or easements herein reserved, pursuant to the Declaration or as necessary to prevent damage to the Common Elements or to a Unit or Units.

Wherever in this Section or elsewhere in this Declaration an easement is granted or reserved to any party, such easement shall also benefit such party's successors, grantees, assigns, agents, employees, licensees, invitees and guests. All easements referred to herein shall be non-exclusive easements.

3.5 Special Easements and Rights to Grant Easements.

(a) Developer hereby reserves unto itself and its successors and its assigns, and grants to the Association with the power to assign, non-exclusive easements over, under and through the Condominium Property for the construction, maintenance and operation of electric, gas or other utility, cable television, security systems, communications, service or other easements pertaining to the construction, maintenance and operation of other equipment, conduits, pipes, lines and similar installations servicing the Condominium Property or other property with the power to relocate any such existing easements in any portion of the Condominium Property and/or Association Property, provided that such easements or the relocation of easements will not prevent or unreasonably interfere with the reasonable use of the Units for residential purposes.

Furthermore, until the Developer no longer holds units for sale or lease in the ordinary course of business or when the unit owners have assumed control of the Association, whichever comes first, Developer shall have the right and license for itself, its agents, successors and assigns to use, lease or assign any space on the roofs of the Condominium buildings provided that such space is not already assigned as a Limited Common Element to a

Residential Unit to any Person(s) for the construction, installation, use, maintenance, repair, replacement, improvement, removal and operation of telecommunication equipment signage. Developer shall have a non-exclusive, and irrevocable easement over the roof areas to exercise its rights set forth above. Without limitation this easement shall include the right to construct, install, use, maintain, repair, replace, improve, remove and operate any type of telecommunication equipment and signage on the roofs of the Condominium buildings. In addition, Developer shall have a non-exclusive and irrevocable easement over other portions of the Condominium for access to and from such roof areas and to construct, install, use, maintain, repair, replace, improve, remove and operate any utility lines servicing such telecommunication equipment. Notwithstanding the above, the Developer shall install such utility lines and locations already used for such purposes or in which other utilities lines are located. Developer and the Association hereby agree to indemnify each other for any damage or destruction caused to the property of the other in the exercise of any easement right granted in this Declaration.

Notwithstanding the foregoing, all easements, reservation and rights retained by Developer in this Section 3.5(a) shall terminate and be cancelable by the association once Unit Owners other than the Developer have assumed control of the association or when the Developer no longer offers units for sale or lease in the ordinary course of business, whichever occurs first.

(b) Developer hereby reserves unto itself and its successors and its assigns, and grants to the Association with the power to assign, non-exclusive easements over, under, upon and through the Condominium Property for the purposes of access to, constructing or maintaining improvements upon, providing utility services to or across, or providing drainage to or from the Condominium Property, any other property which may become part of the Condominium Property pursuant to this Declaration, or any other property adjacent to the Condominium Property, provided that any such easement shall not interfere with the reasonable use of the Units for residential purposes.

(c) Developer hereby reserves unto itself and its successors and its assigns non-exclusive easements over, upon, and through the Condominium Property for vehicular and/or pedestrian traffic by the Developer, its designees, successors, assigns, licensees, lessees, invitees, and guests within the Condominium Property, provided that any such easement shall not interfere with the reasonable use of the Units for residential purposes.

(d) Developer hereby reserves the right to install all lines, pipes and facilities throughout the Condominium Property as may be needed for the use of the Units individually and/or collectively from time to time. Developer shall assume all costs associated with such installations. Subsequent to installation, unless otherwise provided and agreed to by the affected Unit Owner(s), the Association shall be responsible for the maintenance of such lines, pipes and facilities.

(e) For as long as the Developer remains liable under any warranty, whether statutory, expressed, or implied, for any act or omission in the development of the Building or in the sale or marketing thereof, the Developer shall have the right to enter on the Condominium Property, and to take all actions necessary or convenient for the purpose of inspecting, testing, surveying, to determine the actions needed to fulfill any warranty or to determine the extent of the warranty, and to take those actions necessary to fulfill the Developer's responsibilities under the warranty. The Developer can nullify any warranty if the Association or a Unit Owner prohibit or limit access to the Common Elements or to a Unit as deemed necessary by the Developer in its sole discretion for any actions pursuant to the warranty.

(f) Developer hereby reserves the right to assign all or a portion of its rights hereunder, or all or a portion of such rights in connection with specific portions of the Condominium. In the event of any partial assignment, the assignee shall not be deemed the Developer, but may exercise such rights of the Developer as are specifically assigned to it. Any such assignment may be made on a nonexclusive basis. The rights of Developer under this Declaration are independent of the Developer's rights to control the Board of Directors of the Association, and, accordingly, shall not be deemed waived, transferred or assigned to the Unit Owners, the Board or the Association upon the transfer of control of the Association. Any assignment of Developer rights shall be evidenced by an instrument recorded with the formalities of a deed in the public records of the County.

3.6 Incidental Damage. Any damage to any Unit caused by, or as a result of, the carrying out of the maintenance responsibilities of the Association or another Unit Owner, or the negligence thereof, shall be repaired promptly by the Association as a Common Expense, or the Unit Owner, as the case may be. Any damage to any part of the Common Elements caused by or the result of any intentional act of a Unit Owner, the Unit Owner's family, agents, contractors, invitees, licensees or tenants, or by such Unit Owner in carrying out his maintenance responsibilities, if any, shall be repaired promptly at the expense of such Unit Owner.

3.7 Use of Multiple Units to Form One Comprehensive Residential Unit. A Unit may be combined with either the Unit directly above the subject Unit and/or the Unit directly below the subject Unit and/or the laterally-adjacent Unit in order to permit occupancy of such areas as one comprehensive residential space or commercial space. Such a combination of Units shall be for purposes of occupancy and use only and shall not be deemed an amendment to this Declaration. Further, any such combination shall not be considered to be a material alteration of or modification to the configuration or size of a Unit. In all events, the subject Units shall in no manner be considered to become one Unit, but rather shall at all times remain and be considered to exist in the same manner as prior to the combination for purposes of Assessments, voting and all other matters as provided herein.

Any such combination of Units shall be required to comply with all applicable building, health, safety, and other applicable codes and laws as may be applicable. Additionally, no construction activities to effect such a combination shall be commenced without the prior written approval of the Board of Directors, which approval cannot be unreasonably withheld. The Board shall ensure that the combination of Units shall have no detrimental impact on the structural integrity of the Building or the usage of the other Units in the Building. The Board shall act in a reasonable and prudent manner in recognizing the rights of the Owner to combine such Units in the manner contemplated by this paragraph. The Developer shall be exempt from the approval provisions of this paragraph.

Section 4: Restraint upon Separation and Partition of Common Elements

The undivided share in the Common Elements and Common Surplus which is appurtenant to a Unit, and the exclusive right to use all appropriate appurtenant Limited Common Elements, shall not be separated from such Unit

and shall pass with the title to the Unit, whether or not separately described. The appurtenant share in the Common Elements and Common Surplus, and the exclusive right to use all Limited Common Elements appurtenant to a Unit, cannot be conveyed or encumbered, except together with such Unit. The respective shares in the Common Elements appurtenant to Units shall remain undivided, and no action for partition of the Common Elements, the Condominium Property, or any part thereof, shall be undertaken, except as provided herein with respect to termination of the Condominium.

**Section 5: Ownership of Common Elements and Common Surplus and
Share of Common Expenses; Voting Rights**

5.1 Ownership Shares. The undivided share in the Common Elements and Common Surplus appurtenant to each Unit, as well as the undivided share of the Common Expenses to be paid with respect to each Unit, shall be computed on the following basis:

(a) The allocation of percentage shares in the Common Elements and Common Surplus, and the percentage share of the Common Expenses, appurtenant to each Unit is set forth in Exhibit "B" as attached hereto and made a part hereof by this reference. The allocation of percentage shares has been established by the Developer in the following manner:

(i) The approximate area of each Unit has been measured in square feet based upon the surface of the walls bounding the Unit.

(ii) The total of the Unit Area of all Units has been computed and is hereinafter referred to as the "Total Unit Area."

(iii) The Total Unit Area has been divided into the Unit Area of each Unit to determine the allocation of percentage shares for each Unit as set forth on Exhibit "D" to this Declaration.

(b) The foregoing methods of calculation were undertaken in order to establish a fair and equitable method of allocating sales values and assessment percentages to Units within the Condominium.

5.2 Voting. Each Unit Owner shall be a member of the Association. Each Unit shall be entitled to one vote to be cast by its Owner in accordance with the provisions of the By-Laws and Articles of Incorporation of the Association. The total number of votes shall at all times be equal to the number of Units submitted to the condominium form of ownership under this Declaration. Membership in the Association shall automatically terminate upon the termination of ownership of a Condominium Parcel, and the subsequent owner(s) taking title shall automatically become entitled to membership.

Section 6: Amendments

6.1 Amendment by Unit Owners. Except as otherwise provided in Section 6 herein below or elsewhere in this Declaration or the exhibits attached hereto, this Declaration (including the Condominium Plat) may be amended by affirmative vote of the Owners of 75% of all the Condominium Parcels at an Association meeting duly called for such purpose pursuant to the By-Laws; provided, however, that (1) no amendment to this Declaration shall be made which affects any of the rights and privileges provided to the Developer as defined herein without the written consent of such Developer, and (2) no amendment may change the configuration or size of a Unit without the written consent of the affected Unit Owner(s) and all record owners of liens, and (3) no amendment may change the configuration or size of any condominium Unit in any material fashion, unless the record Unit Owner(s) and all record owners of liens join in the execution of the amendment and unless at least a majority of the record owners of all other units approve the amendment.

6.2 Amendment by Developer.

(a) Amendment to Condominium Plans and Declaration. The Developer reserves the right to make whatever changes it may deem necessary in the Condominium Plat and this Declaration until such time as 51% of the Units have been conveyed to third parties not related to or affiliated with the Developer. The amendment reflecting such changes need only be executed by the Developer; provided, however, that no such amendment unilaterally approved by the Developer shall create timeshare estates, change the configuration or size of any Unit in any material fashion, materially alter or modify the appurtenances to any Unit, or change the proportion or percentage by which a Unit Owner shares the Common Expenses and owns the Common Surplus, unless such amendment is also approved by the record Owner of the affected Unit, all record owners of liens on such affected Unit, and at least a majority of the total voting interests of the Association.

(b) Special Amendment. Developer reserves the right and power to record a special amendment ("Special Amendment") to this Declaration at any time and from time to time which amends the Declaration and any provision therein (i) to comply with requirements of the FNMA, FHLMC, the Government National Mortgage Association, the Department of Housing and Urban Development, the Federal Housing Administration, the Veteran's Administration, or any other governmental agency or any other public, quasi-public or private entity which performs (or may in the future perform) functions similar to those currently performed by such entities; (ii) to induce any of such agencies or entities to make, purchase, sell, insure, guarantee or otherwise deal with first mortgages covering Units; and (iii) to bring this Declaration into compliance with applicable laws, ordinances or governmental regulations. In furtherance of the foregoing, a power coupled with an interest is hereby reserved and granted to the Developer to make or consent to a Special Amendment on behalf of each Unit Owner and the Association. Each deed, mortgage, trust deed, other evidence of obligation, or other instrument affecting a Unit and the acceptance thereof shall be deemed to be a grant and acknowledgement of, and a consent to the reservation of, the power of the Developer to make, execute and record Special Amendments. The right and power to make Special Amendments hereunder shall terminate on the turnover of the association to the Unit Owners other than the Developer.

(c) This Declaration and all exhibits hereto, where applicable, may be amended unilaterally by the Developer for the purposes set forth and pursuant to Section 718.110(5), Florida Statutes, to correct scrivener's errors.

6.3 Execution and Recording. An amendment, other than amendments made by the Developer alone pursuant to the Act or this Declaration, shall be evidenced by a certificate of the Association which shall include recording data identifying the Declaration and shall be executed with the same formalities required for the execution of a deed. Amendments by the Developer must be evidenced by a similar certificate executed by the Developer alone. An amendment of the Declaration is effective when the applicable certificate is properly recorded in the public records of the County.

6.4 Limitation. No amendment may be adopted which would eliminate, modify, prejudice, abridge or otherwise adversely affect any rights, benefits, privileges or priorities granted or reserved to the Developer without the consent of said Developer in each instance. The provisions of this paragraph may not be amended in any manner.

6.5 Procedure. No provision of this Declaration shall be revised or amended by reference to its title or number only. Proposals to amend existing provisions of this Declaration shall contain the full text of the provision to be amended, new words shall be inserted in the text underlined, and words to be deleted shall be lined through with hyphens. However, if the proposed change is so extensive that this procedure would hinder, rather than assist, the understanding of the proposed amendment, it is not necessary to use underlining and hyphens as indicators of words added or deleted, but, rather, a notation must be inserted immediately preceding the proposed amendment in substantially the following language: "Substantial rewording of Section _____ of the Declaration. See provision _____ for present text." Nonmaterial errors or omissions in the amendment process shall not invalidate an otherwise properly promulgated amendment.

Section 7: Maintenance and Repairs

7.1 Responsibility for the maintenance, repair and replacement of the Condominium Property is as follows:

(a) Common Elements. In addition to items to be maintained pursuant to Section 3.3 hereof, the Association shall manage, maintain, repair and replace, as part of the Common Expenses, all of the Common Elements as defined herein (except with respect to the Residential Limited Common Elements, as to which, anything herein to the contrary notwithstanding, all costs and expenses shall be paid solely by the Residential Unit Owners), including, but not limited to, the following:

- (i) all drainage and storm-water management systems, driveways, and adjacent drainage;
- (ii) all water and wastewater lines and piping serving the Units of the Condominium;
- (iii) all landscaping, lawn and grass areas and sprinkler systems within the Condominium Property;
- (iv) all entryways to the Buildings (other than living space and stairwells) and any controlled access and intercom systems serving the building (but specifically excluding the security systems for the Residential Units and the Commercial Units which specifically serve such Unit, and all fire and emergency warning systems and lights.
- (v) all portions of any landscaping islands located on, either in whole or in part, or adjacent to the Condominium Property.

However, the Association shall not perform such maintenance required of a Unit Owner who utilizes portions of the Limited Common Elements in accordance with Section 3.3 herein, as otherwise contemplated herein, or to the extent such maintenance arises from or is necessitated by the negligence, misuse or neglect of specific Unit Owners, in which case such cost and expense shall be paid solely by such Unit Owners.

(b) Units. The responsibility for maintenance, repair and replacement within the Units shall be shared by the Association and the Unit Owners as follows:

(i) By the Association. The Association shall be responsible for maintaining, repairing and replacing all water and wastewater lines and piping located outside of the Unit (except as otherwise stated in sub-paragraph (ii) below), all pipes, lines, wiring, facilities and conduits located within the walls and any soffits contained within a Unit and which provides services to more than one Unit, and any portions of any fire protection and emergency warning systems, including, sprinklers, alarms, dampers, barriers and lights contained within the physical boundaries of and servicing a Unit. In addition, with regard to the Residential Units, the Association shall be responsible for (1) maintaining the exterior surfaces (defined to be those walls that are visible from the exterior of the Building) and interior portions of all walls that serve to bound the balcony area contained within a Residential Unit and (2) painting the exterior surfaces of the front entry doors and the doors leading to the balcony from the living area and the cost of such maintenance shall constitute common expenses for the Residential Units. In accordance with Section **[20.1]**, a Unit Owner shall be liable for the expense of any maintenance, repair or replacement of any part of the Unit to be maintained by the Association under this paragraph made necessary by his negligence, misuse or neglect or by that of any member of his family or his or their guests, employees, agents or lessees.

(ii) By the Unit Owner. Each Unit Owner shall maintain, repair and replace everything within the confines of the Owner's Unit, which is not to be maintained by the Association pursuant to subsection (b)(i) of this section, including, but not limited to:

(A) The entire Unit as defined in Section 3.2 hereof which Unit shall include, without limitation, all apertures in any boundary of the Unit but which shall exclude the exterior surfaces made of

glass or other transparent material and the exterior of doors, which shall be maintained by the Unit Owner in such manner to preserve a uniform appearance among the Units in the Buildings;

- (B) The interior side of the entrance door to a Unit and the interior side of all other doors affording access to a Unit;
- (C) Interior paint, finish, covering, wallpaper and decoration of all walls, floors and ceilings;
- (D) All built-in shelves, cabinets, counters, storage areas and closets;
- (E) Any and all appliances and mechanical, ventilating, heating and air conditioning equipment contained within and serving the Unit;
- (F) All bathroom fixtures, equipment and apparatuses;
- (G) All electrical, plumbing (including connections and fixtures), telephone and television fixtures, apparatuses, equipment, outlets, switches, wires, pipes and conduits, ducts, electric lines and other facilities for the furnishing of utility and other services between the Unit and its individual service panel or meter or contained within a Unit;
- (H) All interior doors, interior surfaces, non-load-bearing walls, partitions, and room dividers;
- (I) All furniture, furnishings and personal property contained within the respective Unit; and
- (J) Balconies and storage facilities located thereon, if any;
- (K) Where a Limited Common Element consists of a balcony or terrace, the Unit Owner who has the right to the exclusive use of said balcony or right to the exclusive use of said balcony or terrace shall be responsible for the maintenance, care and preservation of the paint and surface of the walls and/or fences, including floor and ceiling, within said area, if any, and the fixed and/or sliding glass door(s) in the entrance way(s) and/or sliding glass door(s) in the entrance way(s) or other portions of said area, if any, and the wiring, electrical outlet(s) and fixture(s) thereon, if any, and the replacement of light bulbs, if any. Notwithstanding the foregoing, the Association shall maintain and repair the railings affixed to the balconies and the top wall of the balconies, which costs and expenses for said maintenance and repair of the railings and top wall of the balconies shall be a Common Expense to all Unit Owners;
- (L) Storage locker, if applicable.
- (M) All other maintenance or repair of or replacements involving a Unit as contemplated and authorized hereunder.

7.2 Notwithstanding the provisions of Section 7.1 herein, all modifications to the exterior of a Residential Unit must be approved in writing by the Board, or a committee designated by the Board and headed by an officer of the Association, prior to commencement of such work so as to maintain the character and to preserve the aesthetic and architectural qualities of the Condominium. The Association shall promulgate rules and regulations in accordance with the foregoing.

Section 8: Additions, Alterations or Improvements by the Association

Whenever, in the judgment of the Board of Directors, the Common Elements, or any part thereof, shall require capital additions, alterations or improvements (as distinguished from maintenance, repairs and replacements) costing in excess of \$50,000.00 in the aggregate in any calendar year, shall be considered material and substantial in nature, and the Association may proceed with such additions, alterations or improvements only if the making of such additions, alterations or improvements shall have been approved by the Owners of a majority of the Units represented at a meeting at which a quorum is attained. Any other such additions, alterations or improvements to such Common Elements, or any part thereof, costing in the aggregate \$50,000.00 or less in a calendar year may be made by the Board of Directors without approval of the Unit Owners. The cost and expense of any such additions, alterations or improvements to such Common Elements shall be as a "Capital Improvement Assessment" of the Unit Owners as provided in Section 13.2 hereof. For purposes of this Section 8, "aggregate in any calendar year" shall include the total debt incurred in that year, if such debt is incurred to perform the above-stated purposes, regardless of whether the repayment of any part of that debt is made beyond that year.

Section 9: Additions, Alterations or Improvements by Unit Owner

9.1 To the Common Elements. After the completion of the improvements included in the Common Elements which are set forth in this Declaration, or which are contemplated by the Developer in the completion of the development as set forth herein, there shall be no alterations or additions to the Common Elements (which by definition includes the Limited Common Elements), except as authorized by the Board of Directors and approved by not less than 75% of the total vote of the Unit Owners. In addition to the foregoing requirement, no alterations or additions may be made involuntarily to the Limited Common Elements of any particular Unit if such alteration or addition will adversely affect or prejudice the rights of such Unit Owner unless his consent first has been obtained. The cost of the foregoing shall be assessed as Common Expenses unless otherwise provided herein.

9.2 To the Units. Except as otherwise reserved by the Developer or detailed in Sections 3.4 or 18 herein, no Unit Owner shall make any alteration or improvement to such Owner's Unit except in accordance with this Section 9.2. A Unit Owner may make alterations and improvements to the interior of the Unit so long as such

alterations or improvements are not visible from the outside of the Unit or the Buildings, do not impair the structural integrity of the Unit or the Buildings, do not otherwise violate the terms of this Declaration, and are in compliance with all applicable building codes and laws. A Unit Owner may not expand, enlarge or relocate his Unit. Other alterations or improvements to a Unit which are not discussed in this Declaration may be made only if prior approval in writing is obtained from the Board or a committee designated by the Board and headed by an officer of the Association.

9.3 Indemnification by Unit Owner. A Unit Owner making or causing to be made any such additions, alterations or improvements to the Unit or the Limited Common Elements as contemplated herein agrees, and shall be deemed to have agreed, for such Owner, and such Owner's heirs, personal representatives, successors and assigns, as appropriate, to hold the Association and all other Unit Owners harmless from and to indemnify them for any liability or damage to the Condominium Property and expenses arising therefrom, and shall be solely responsible for the maintenance, repair and insurance thereof from and after that date of installation or construction thereof as may be required by the Association.

9.4 Power of Developer to Veto Certain Proposed Modifications. Notwithstanding any provision to the contrary, the Developer, having the intention in its development of the Condominium to maintain an uniform external appearance to the Buildings, shall have the power, until such time as the Developer no longer offers any Units for sale or lease in the ordinary course of business, to veto any proposed improvement as contemplated by this Section.

Section 10: Additions, Alterations or Improvements by Developer or Commercial Unit Owners

The restrictions of Section 9 hereof shall not apply to Developer-owned Units or Commercial Units. The Developer shall have the additional right, without the consent or approval of the Board of Directors or other Unit Owners, to make alterations, additions or improvements, structural and non-structural, interior and exterior, ordinary and extraordinary, in, to and upon any Unit owned by it, to the proposed or already constructed Unit located or to be located thereon, and Limited Common Elements appurtenant thereto. Such modifications shall include, without limitation: (i) the removal of walls, floors, ceilings and other structural portions of the Unit; (ii) changes to the layout or number of rooms in any Developer-owned Units; and (iii) changes to the size and/or number of Developer-owned Units by combining separate Developer-owned Units or otherwise. Any amendments to this Declaration or the Condominium Plat required by actions taken pursuant to this Section may be effected by the Developer alone without the consent of any other person; provided, however, if any such amendment shall change the configuration or size of any Unit in any material fashion, materially alter or modify the appurtenances to the Unit, or change the proportion or percentage by which the Unit Owner shares the Common Expenses and owns the Common Surplus, the execution of the amendment to the Declaration effecting such change must be joined in by the record owners of the Unit, all record owners of liens on the affected Unit, and at least seventy-five percent (75%) of the total voting interests in the Association. Without limiting the generality of Section 6.5 hereof, the provisions of this Section may not be added to, amended or deleted unless by, or with the prior written consent of, the Developer.

Section 11: Operation of the Condominium by the Association; Powers and Duties

11.1 Powers and Duties. The Association shall be the entity responsible for the operation of the Condominium. The powers and duties of the Association shall include those set forth in the By-Laws and Articles of Incorporation as amended from time to time. In addition, the Association shall have all the powers and duties set forth in the Act, as well as all powers and duties granted to or imposed upon it by this Declaration, including, without limitation:

(a) The irrevocable right to have access to any portion of each Unit and the Limited Common Elements appurtenant thereto from time to time during reasonable hours as may be necessary for the maintenance, repair or replacement of such portions thereof as required by this Declaration or the Act, for performing extermination services, or at any time and by force, if necessary, for making emergency repairs necessary to prevent damage to the Buildings, the Common Elements or to the Unit or any other Unit or Units.

(b) The power to make and collect Assessments and other related expenses authorized under the Act against Unit Owners, to lease, maintain, repair and replace the Common Elements, and to grant, modify or cancel easements pertaining to the Common Elements.

(c) The duty to maintain accounting records, according to good accounting practices, which shall be open to inspection by Unit Owners or their authorized representatives at reasonable times upon prior request.

(d) The power to contract for the management and maintenance of the Condominium Property and to authorize a duly licensed management agent (who may be an affiliate of the Developer) to assist the Association in carrying out its powers and duties by performing such functions as the submission of proposals, collection of Assessments, preparation of records, enforcement of rules and regulations, and perform the maintenance, repair and replacement required of the Association with such funds as shall be made available by the Association for such purposes. The Association also shall have the power to join with other condominium associations and entities in contracting for the maintenance and repair of the properties of such other condominiums and other type properties, and may contract for or may join with other condominium associations in contracting for the management of the properties of such other condominiums and other type properties, as may be more specifically provided for by the Articles of Incorporation and By-Laws of the Association.

(e) The power to borrow money, execute promissory notes and other evidences of indebtedness and to give as security therefor mortgages and security interests in property owned by the Association, if any. Such actions must be approved by a majority of the Board of Directors and a majority of the Owners of all the Units or by such greater percentage of the Board or Unit Owners as may be specified in the By-Laws with respect to certain borrowing, and no such action shall be permitted while the Developer owns any Unit without the prior written consent of the Developer.

(f) The power to adopt and amend rules and regulations concerning the details of the operation and use of the Condominium Property.

(g) The power to acquire, lease, mortgage and convey real and personal property and to grant, modify and cancel easements regarding such property, provided that such action may be done only (i) upon the approval of a majority of the Board of Directors and (ii) a finding by the Board that such action is for the benefit of the members of the Association. The requirements of Section 8 pertaining to the Unit Owners' approval of costs in excess of the threshold amount stated therein (including the proviso as to the debt incurred) shall also apply to this acquisition and dealing with Association-owned property; provided, however, that the acquisition of a Unit as a result of a foreclosure of the lien for Assessments shall be exempt from these requirements.

(h) The power to acquire or enter into agreements acquiring leaseholds, memberships or other possessory or use interests in lands or facilities for recreational purposes as long as such arrangements are also approved by the Owners of a majority of the Units.

(i) All of the powers which a corporation not-for-profit in the State of Florida may exercise pursuant to this Declaration, the Articles of Incorporation and By-Laws, Chapter 617, Florida Statutes, and the Act, in all cases except as expressly limited or restricted in the Act or the documents of the Condominium.

11.2 Conflict. In the event of conflict among the powers and duties of the Association or the terms and provisions of this Declaration or the exhibits attached hereto, this Declaration shall take precedence over the Articles of Incorporation, By-Laws and applicable rules and regulations; the Articles of Incorporation shall take precedence over the By-Laws and applicable rules and regulations; and the By-Laws shall take precedence over applicable rules and regulations, all as amended from time to time. Notwithstanding anything in this Declaration or its exhibits to the contrary, the Association shall at all times be the entity having ultimate authority over the Condominium, consistent with the Act.

11.3 Limitation of Liability of Association. Notwithstanding the duty of the Association to maintain and repair parts of the Condominium Property, the Association shall not be liable to Unit Owners for injury or damage, other than for the cost of maintenance and repair, caused by any latent condition of the Condominium Property. Further, the Association shall not be liable for any such injury or damage caused by defects in design or workmanship or any other reason connected with any additions, alterations or improvements done by or on behalf of any Unit Owners, regardless if whether or not same shall have been approved by the Association pursuant to the provisions hereof.

NOTWITHSTANDING ANYTHING CONTAINED HEREIN OR IN THE ARTICLES OF INCORPORATION, BY-LAWS, ANY RULES OR REGULATIONS OF THE ASSOCIATION OR ANY OTHER DOCUMENT GOVERNING OR BINDING THE ASSOCIATION (COLLECTIVELY, THE "ASSOCIATION DOCUMENTS"), THE ASSOCIATION SHALL NOT BE LIABLE OR RESPONSIBLE FOR, OR IN ANY MANNER BE A GUARANTOR OR INSURER OF, THE HEALTH, SAFETY OR WELFARE OF ANY OWNER, OCCUPANT OR USER OF ANY PORTION OF THE CONDOMINIUM PROPERTY, INCLUDING, WITHOUT LIMITATION, RESIDENTS AND THEIR FAMILIES, GUESTS, INVITEES, AGENTS, SERVANTS, CONTRACTORS OR SUBCONTRACTORS OR FOR ANY PROPERTY OF ANY SUCH PERSONS. WITHOUT LIMITING THE GENERALITY OF THE FOREGOING:

(a) **IT IS THE EXPRESS INTENT OF THE ASSOCIATION DOCUMENTS THAT THE VARIOUS PROVISIONS THEREOF WHICH ARE ENFORCEABLE BY THE ASSOCIATION AND WHICH GOVERN OR REGULATE THE USES OF THE CONDOMINIUM PROPERTY HAVE BEEN WRITTEN, AND ARE TO BE INTERPRETED AND ENFORCED, FOR THE SOLE PURPOSE OF ENHANCING AND MAINTAINING THE ENJOYMENT OF THE CONDOMINIUM PROPERTY AND THE VALUE THEREOF;**

(b) **THE ASSOCIATION IS NOT EMPOWERED, AND HAS NOT BEEN CREATED, TO ACT AS AN ENTITY WHICH ENFORCES OR ENSURES THE COMPLIANCE WITH THE LAWS OF THE UNITED STATES, STATE OF FLORIDA, DUVAL COUNTY, CITY OF JACKSONVILLE OR ANY OTHER JURISDICTION OR THE PREVENTION OF TORTIOUS ACTIVITIES; AND**

(c) **ANY PROVISIONS OF THE ASSOCIATION DOCUMENTS SETTING FORTH THE USES OF ASSESSMENTS WHICH RELATE TO HEALTH, SAFETY AND/OR WELFARE SHALL BE INTERPRETED AND APPLIED ONLY AS LIMITATIONS ON THE USES OF ASSESSMENT FUNDS AND NOT AS CREATING A DUTY OF THE ASSOCIATION TO PROTECT OR FURTHER THE HEALTH, SAFETY OR WELFARE OF ANY PERSON(S), EVEN IF ASSESSMENT FUNDS ARE CHOSEN TO BE USED FOR ANY SUCH REASON.**

EACH UNIT OWNER (BY VIRTUE OF HIS ACCEPTANCE OF TITLE TO HIS UNIT) AND EACH OTHER PERSON HAVING AN INTEREST IN OR LIEN UPON, OR MAKING ANY USE OF, ANY PORTION OF THE CONDOMINIUM PROPERTY (BY VIRTUE OF ACCEPTING SUCH INTEREST OR LIEN OR MAKING SUCH USES) SHALL BE BOUND BY THIS PROVISION AND SHALL BE DEEMED TO HAVE AUTOMATICALLY WAIVED ANY AND ALL RIGHTS, CLAIMS, DEMANDS AND CAUSES OF ACTION AGAINST THE ASSOCIATION ARISING FROM OR CONNECTED WITH ANY MATTER FOR WHICH THE LIABILITY OF THE ASSOCIATION HAS BEEN DISCLAIMED IN THIS PROVISION.

AS USED IN THIS SECTION, "ASSOCIATION" SHALL INCLUDE WITHIN ITS MEANING ALL OF THE ASSOCIATION'S DIRECTORS, OFFICERS, COMMITTEE AND BOARD MEMBERS, EMPLOYEES, AGENTS, CONTRACTORS (INCLUDING MANAGEMENT COMPANIES), SUBCONTRACTORS, SUCCESSORS AND ASSIGNS. THE PROVISIONS OF THIS ARTICLE SHALL ALSO INURE TO THE BENEFIT OF THE DEVELOPER AND ITS AFFILIATES, WHICH SHALL BE FULLY PROTECTED HEREBY.

11.4 Restraint Upon Assignment of Shares in Assets. The share of a Unit Owner in the funds and assets of the Association cannot be assigned, hypothecated or transferred in any manner except as an appurtenance to such Owner's Unit.

11.5 Approval or Disapproval of Matters. Whenever the decision of a Unit Owner is required upon any matter, whether or not the subject of an Association meeting, that decision shall be expressed by the same person who would cast the vote for that Unit if at an Association meeting, unless the joinder of all record Owners of the Unit is specifically required by this Declaration or by law.

11.6 Acts of the Association. Unless the approval or action of Unit Owners and/or a certain specific percentage of the Board of Directors is specifically required in this Declaration, the Articles of Incorporation, the By-Laws, applicable rules and regulations of the Association or applicable law, all approvals or actions required or permitted to be given or taken by the Association shall be given or taken by the Board of Directors without the consent of Unit Owners, and the Board may so approve and act through the proper officers of the Association without a specific resolution. When an approval or action of the Association is permitted to be given or taken hereunder or thereunder, such action or approval may be conditioned in any manner the Association deems appropriate or the Association may refuse to take or give such action or approval without the necessity of establishing the reasonableness of such conditions or refusal.

11.7 Amendment of By-Laws. No modification of or amendment to the By-Laws shall be valid unless set forth in or annexed to a duly recorded amendment to this Declaration. The By-Laws may be amended in the manner provided for therein, but no amendment to the By-Laws shall be adopted which would affect or impair the validity or priority of any mortgage covering any Condominium Parcel(s), or which would change the provisions of the By-Laws with respect to institutional mortgages without the written approval of all Institutional First Mortgagees of record. No amendment shall change the rights and privileges of the Developer without Developer's respective written consent. Any amendment to the By-Laws, as provided herein, shall be executed by the parties as required in this Section 11 and in Section 6 above, and said amendment shall be recorded in the public records of the County.

11.8 Binding Effect of Condominium Documents. Every Owner, whether having acquired ownership of a Unit by gift, conveyance or transfer by operation of law, or otherwise, shall be bound by the Articles of Incorporation, the By-Laws, the provisions of this Declaration and the management agreement. Membership in the Association shall automatically terminate upon the termination of ownership of a Condominium Parcel, and the subsequent Owner(s) taking title shall automatically become entitled to membership.

Section 12: Management Agreement

The Association may enter into a Management Agreement with an individual or company licensed to perform the duties of managing the condominiums property.

Section 13: Determination of Assessments

13.1 General Assessment. The Board of Directors shall from time to time, and at least annually, prepare and adopt a budget for the Condominium ("Budget for Common Expenses"), determine the amount payable by the Unit Owners to meet the Common Expenses of the Condominium, and allocate and assess such expenses among the Unit Owners in accordance with the provisions of this Declaration and the By-Laws ("General Assessment"). The Board of Directors shall advise all Unit Owners promptly in writing of the amount of the General Assessment payable by each of them as determined by the Board of Directors as aforesaid. The Budget for Common Expenses shall include the reserves required by law or determined appropriate by the Board, the costs of carrying out the powers and duties of the Association and any other expenses designated as Common Expenses by the Act, this Declaration, the Articles of Incorporation, the By-Laws or applicable rules and regulations of the Association. Incidental income to the Association, if any, may be used to pay regular or extraordinary Association expenses and liabilities, to fund reserve accounts, or otherwise as the Board shall determine from time to time, and need not be restricted or accumulated. Any adopted Budget for Common Expenses shall be subject to change by the Board of Directors, and the amount of the General Assessment shall be changed in accordance with such revised Budget for Common Expenses to cover actual expenses at any time. The expense of installation, replacement, operation, repair and maintenance of hurricane shutters by the Board pursuant to Section 7.3 of this Declaration and the Act shall constitute a Common Expense and shall be collected as provided in this Section. A Unit Owner who has previously installed hurricane shutters in accordance with Section 7.3 of this Declaration or laminated glass architecturally designed to function as hurricane protection which complies with the applicable building code shall receive a credit equal to the pro rata portion of the assessed installation cost assigned to each Unit. However, such Unit Owner shall remain responsible for the pro rata share of expenses for hurricane shutters installed on Common Elements of expenses for hurricane shutters installed on Common Elements and Association Property by the Board pursuant to Section 7.3 of this Declaration and shall remain responsible for a pro rata share of the expense of the replacement, operation, repair and maintenance of such shutters. Additionally, the cost of a master antenna television system or duly franchised cable television service, if any, obtained pursuant to a bulk contract, shall be deemed to be a Common Expense. The Board of Administration in Owners shall be authorized to include such costs in the provisions of this Declaration with respect to the collection of Assessments shall be applicable to the costs for cable television services and auxiliary services.

13.2 Special Assessments and Capital Improvement Assessments. In addition to General Assessments, the Board of Directors may levy "Special Assessments," and "Capital Improvement Assessments" upon the following terms and conditions:

(a) "Special Assessments" shall mean or refer to amounts levied against each Owner and such Owner's Unit, representing a portion of the costs incurred by the Association for specific purposes of a nonrecurring nature which are not in the nature of capital improvements. The Association may use the provisions of Section 13 of this Declaration to enforce payment of the shares of such Special Assessment.

(b) "Capital Improvement Assessments" shall mean and refer to amounts levied against each Owner and such Owner's Unit, representing a portion of the costs incurred by the Association for the acquisition, installation, construction or replacement (as distinguished from maintenance, repairs and replacement) of any capital improvements located or to be located within the Common Elements.

(c) Special Assessments and Capital Improvement Assessments may be levied by the Board of Directors and shall be payable in lump sums or installments, in the discretion of the Board; provided that, if such Special Assessments and Capital Improvement Assessments, in the aggregate in any year, exceed \$50,000.00 or cause the total Assessments levied to exceed 115% of Assessments for the preceding calendar year, the Board must obtain approval of a majority of the Owner of Units represented at a meeting duly called, noticed and held in accordance with the By-Laws and the Act.

13.3 "Limited Common Element Charges" shall mean and refer to amounts levied in accordance with Section 718.113(1), Florida Statutes, against the Owners of Units for the maintenance, repair, replacement and/or reconstruction of the Limited Common Elements described in Section 3.3 hereof which are appurtenant to such Units.

Section 14: Collection of Assessments

The General Assessments, Special Assessments, and Capital Improvement Assessments (collectively, the "Assessments") shall be collected as follows:

14.1 Liability for Assessments. A Unit Owner, regardless of how title is acquired, including by purchase at a judicial sale or by deed in lieu of foreclosure, shall be liable for all Assessments coming due while such person (as defined by Section 1.01(3), Florida Statutes) is the Owner of the Unit. Additionally, a Unit Owner shall be jointly and severally liable with the previous owner for all unpaid Assessments that came due up to the time of the conveyance, without prejudice to any right such Unit Owner may have to recover from the previous owner the amounts paid by such Unit Owner. The liability for Assessments may not be avoided by waiver of the use or enjoyment of any Common Elements or by the abandonment of the Unit for which the Assessments are made or otherwise.

14.2 Default in Payment of Assessments. Assessments and installments thereof not paid within 10 days from the date when they are due shall bear interest at the rate established from time to time by the Board of Directors from the due date until paid (provided, however, that no such rate shall exceed the maximum allowed by law). In the event the Board has not established such rate, the interest rate shall be 15%. Each delinquent payment shall be subject to an administrative late fee in an amount not to exceed the greater of \$25.00 or 5% of each delinquent installment. The Association has a lien on each Condominium Parcel for any unpaid Assessments on such Condominium Parcel, with interest thereon, and for reasonable attorney's fees and costs incurred by the Association incident to the collection of the Assessment or enforcement of the lien. The lien shall be effective on the earliest date allowed by law, which shall be no later than as of the recording of the claim of lien. Such lien shall be evidenced by the recording of a claim of lien in the public records of the County, stating the description of the Condominium Parcel, the name of the record Owner, the name and address of the Association, the amounts due and the due dates. The claim of lien shall not be released until all sums secured by it (or such other amount as to which the Association shall agree by way of settlement) have been fully paid or until such claim of lien is barred by law. The claim of lien shall secure (whether or not stated therein) all unpaid Assessments, interest thereon, the administrative late fee (if permitted under applicable law), and costs and attorneys' fees which are due and which may accrue subsequent to the recording of the claim of lien and prior to the entry of a final judgment of foreclosure thereof. A claim of lien shall be signed and acknowledged by an officer or authorized agent of the Association. Upon payment, the person making the payment is entitled to a satisfaction of the lien in recordable form. The Association or its assignee may bring an action to foreclose a lien for unpaid Assessments in the manner a mortgage of real property is foreclosed in Florida and may also bring an action at law to recover a money judgment for the unpaid Assessments and other amounts due without waiving any claim of lien. The Association is entitled to recover its costs and reasonable attorneys' fees incurred in either a lien foreclosure action or an action to recover a money judgment for unpaid Assessments.

As an additional right and remedy of the Association, upon default in the payment of Assessments as aforesaid and after 30 days' prior written notice to the applicable Unit Owner and the recording of a claim of lien, the Association may declare the balance of General Assessment installments due for the remainder of the fiscal year and payments of other known Assessments to be accelerated and shall thereupon be immediately due and payable. In the event that the amount of such accelerated installments or payments changes, the Unit Owner or the Association, as appropriate, shall be obligated to pay or reimburse to the other the amount of increase or decrease within 10 days of same taking effect.

Any payments received by the Association from a delinquent Unit Owner shall be applied first to any interest accrued as provided above, then to any administrative late fee, then to any costs and reasonable attorneys' fees incurred in collection as aforesaid and then to the delinquent and any accelerated Assessments. The foregoing application of funds received shall be applicable despite any restrictive endorsement, designation or instruction placed on or accompanying a payment.

14.3 Notice of Intention to Foreclose Lien. Unless otherwise required by the Act or other applicable law, no foreclosure judgment may be entered until at least 30 days after the Association gives written notice to the Unit Owner of its intention to foreclose its lien to collect the unpaid Assessments. If this notice is not given at least 30 days before the foreclosure action is filed, and if the unpaid Assessments, including those coming due after the claim of lien is recorded, are paid before the entry of a final judgment of foreclosure, the Association shall not recover attorneys' fees or costs. The notice must be given by delivery of a copy of it to the Unit Owner or by certified or registered mail, return receipt requested, addressed to the Unit Owner at the last known address, and upon such mailing, the notice shall be deemed to have been given. If after diligent search and inquiry the Association cannot find the Unit Owner or a mailing address at which the Unit Owner will receive the notice, the court may proceed with the foreclosure action and may award attorneys' fees and costs as permitted by law. The notice requirements of this subsection are satisfied if the Unit Owner records a Notice of Contest of Lien as provided in the Act.

14.4 Appointment of Receiver to Collect Rental. If the Unit Owner remains in possession of the Unit after a foreclosure judgment has been entered, the court in its discretion may require the Unit Owner to pay a reasonable rental for the Unit. If the Unit is rented or leased during the pendency of the foreclosure action, the Association is entitled to the appointment of a receiver to collect the rent, the expenses of such receiver to be paid by the party which does not prevail in the foreclosure action.

14.5 Institutional First Mortgagee. In the event an Institutional First Mortgagee or other purchaser shall obtain title to a Unit by foreclosure, or by deed in lieu of foreclosure, such Institutional First Mortgagee or other purchaser, its successors and assigns, shall be liable for Assessments or other related expenses authorized under the Act secured by the claim of lien only to the extent provided by the Act. If, due to the applicable provisions of the Act, any unpaid share of the Assessments or other related expenses authorized under the Act are not required to be paid, then such unpaid share or other related expenses authorized under the Act shall be deemed to be a Common Expense collectible from all of the Unit Owners, including such acquirer and such acquirer's successors and assigns.

14.6 Certificate of Unpaid Assessments. Within 15 days after request by a Unit Owner or mortgagee of a Unit, the Association shall provide a certificate stating all Assessments and other monies owed to the Association by the Unit Owner with respect to such Owner's Unit. Any person other than the Unit Owner who relies upon such certificate shall be protected thereby.

14.7 Installments. General Assessments shall be collected monthly or quarterly, in advance, as determined from time to time by the Board of Directors. Initially, General Assessments will be collected monthly.

14.8 Developer's Guarantee. If, in the purchase agreement or by other means pursuant to the Act, Developer shall guarantee to each purchaser that the Assessment for a specific period of time will not exceed a certain dollar amount, then the Developer shall only be obligated to pay the amount of Common Expenses incurred during that period and not produced by the Assessments received from other Unit Owners.

Section 15: Insurance

Insurance covering the Condominium Property and the Association Property shall be governed by the following provisions:

15.1 "Insurance Trustee". The Board of Directors of the Association shall have the option in its discretion of appointing an Insurance Trustee hereunder. If the Association fails or elects not to appoint such Insurance Trustee, the Board of Directors will perform directly all obligations imposed upon such Insurance Trustee by this Declaration. Fees and expenses of any Insurance Trustee are Common Expenses.

15.2 Purchase, Custody and Payment.

(a) Purchase. All insurance policies purchased by the Association shall be issued by an insurance company authorized to do business in Florida meeting all criteria established by the Board or the Act and any rules promulgated thereunder.

(b) Named Insured. Under all insurance policies purchased by the Association, the named insured shall be the Association, individually, and as agent for Owners of Units covered by the policy, without naming them, and as agent for their mortgagees, without naming them. The Unit Owners and their mortgagees shall be deemed additional insureds.

(c) Custody of Policies and Payment of Proceeds. All insurance policies purchased by the Association shall provide that payments for losses made by the insurer shall be paid to the Insurance Trustee, and such policies and endorsements thereto shall be deposited with the Insurance Trustee.

(d) Copies to Mortgagees. One copy of each insurance policy, or a certificate evidencing such policy, and all endorsements thereto, shall be furnished by the Association upon request to each Institutional First Mortgagee who holds a mortgage upon a Unit covered by the policy. Copies or certificates shall be furnished not less than 10 days prior to the beginning of the term of the policy, or not less than 10 days prior to the expiration of each preceding policy that is being renewed or replaced, as appropriate.

(e) Exceptions from Association Responsibility; Unit Owner's Personal Coverage. Except as specifically provided herein or by the Act, the Association shall not be responsible to Unit Owners to obtain insurance coverage upon any and all property lying within the boundaries of their Unit, including, but not limited to, their personal property, and for their personal liability and living expense and for any other risks not otherwise insured in accordance herewith.

Unit Owners may be required to purchase flood insurance for their respective Unit(s) if such insurance is required by their mortgagee(s). In the event flood insurance is required, such insurance shall not be for the lesser of 100% of the current replacement cost of the Unit, or the maximum amount of flood insurance available with regard to such property.

The Association shall have no obligation to purchase flood insurance or fire and casualty insurance on the Units.

In accordance with Section 3.5 herein, the Unit Owner shall be solely responsible for insuring any and all equipment, machinery, fixtures, furniture or the like installed and/or placed upon or within the Limited Common Elements appurtenant to such Owner's Unit, as well as any other improvements located within such Limited Common Elements.

Unless the Association elects otherwise, the insurance purchased by the Association shall not cover claims against a Unit Owner due to accidents occurring within such Owner's Unit. It shall be the obligation of the individual Unit Owner, if such Unit Owner so desires, to purchase and pay for insurance as to all such and other risks not covered by insurance carried by the Association.

15.3 Coverage Responsibilities of Association. The Association shall use its best efforts to obtain and maintain adequate insurance covering the following:

(a) Casualty. Insurance covering loss or damage to the Common Elements and all other portions of the Condominium Property which the Association is responsible to maintain under the terms of this Declaration, and all items for which the Association is required under applicable provisions of the Act to insure against loss or damage by fire and against loss or damage by risks now or hereafter embraced by standard extended coverage and vandalism and malicious mischief endorsements (collectively, the "Insured Property"). Such policies may contain reasonable deductible provisions as determined by the Board of Directors. Such coverage shall afford protection against such other risks as from time to time are customarily covered with respect to buildings and improvements similar to the Insured Property in construction, location and use, including, but not limited to, vandalism and malicious mischief.

(b) Liability. Comprehensive general public liability and automobile liability insurance covering loss or damage resulting from accidents or occurrences on or about or in connection with the Insured Property or adjoining driveways and walkways, or any work, matters or things related to the Insured Property, with such coverage as shall be required by the Board of Directors, but with combined single limit liability of not less than \$1,000,000.00 per occurrence, and with a cross liability endorsement to cover liabilities of the Unit Owners as a group to any Unit Owner, and vice versa.

(c) Worker's Compensation and other mandatory insurance, when applicable.

(d) Fidelity Insurance, if required by the Act or FNMA/FHLMC, covering all persons who control or disburse Association funds, such insurance to be in the amount required by law and must cover the maximum funds that will be in the custody of the association or its management agent at any one time. As used in this paragraph, the term "persons who control or disburse funds of the association" includes, but is not limited to, those individuals authorized to sign checks and the president, secretary, and treasurer of the association. The association shall bear the cost of bonding.

(e) Association Property. Appropriate additional policy provisions, policies or endorsements extending the applicable portions of the coverage described above to all Association Property, where such coverage is available.

(f) Such Other Insurance as the Board of Directors shall determine from time to time to be desirable.

When appropriate and obtainable, each of the foregoing policies shall waive the insurer's right to: (i) subrogation against the Association, its officers, members of the Board, the Developer, the Management Firm and its respective employees and agents, and against the Unit Owners individually and as a group; (ii) to pay only a fraction of any loss in the event of coinsurance or if other insurance carriers have issued coverage upon the same risk; and (iii) avoid liability for a loss that is caused by an act of the Board of Directors, a member of the Board of Directors, the Management Firm and its respective employees and agents, the Developer, one or more Unit Owners or as a result of contractual undertakings. Additionally, each policy shall provide that any insurance trust agreement will be recognized, that the insurance provided shall not be prejudiced by any act or omissions of the Management Firm or the individual Unit Owners that are not under the control of the Association, and that the policy shall be primary, even if a Unit Owner has other insurance that covers the same loss.

Every casualty insurance policy obtained by the Association shall have the agreed amount and inflation guard endorsement unless the Board finds such endorsement is unobtainable or economically infeasible.

15.4 Additional Provisions. All policies of insurance shall provide that such policies may not be canceled or substantially modified without at least 30 days' prior written notice to all of the named insureds, including all mortgagees of Units. Prior to obtaining any policy of casualty insurance or any renewal thereof, the Board of Directors may wish to obtain an appraisal from a fire insurance company, or other competent appraiser, of the full insurable replacement value of the Insured Property (exclusive of foundations), without deduction for depreciation, for the purpose of determining the amount of insurance to be effected pursuant to this Section.

15.5 Premiums. Premiums upon insurance policies purchased by the Association shall be paid by the Association as a Common Expense, except that the costs of fidelity bonding for any management company employee may be paid by such company pursuant to their agreement with the Association and except that the portion of such premiums attributable to the Residential Limited Common Elements shall be deemed part of the Residential Limited Common Element Expenses. Premiums may be financed in such manner as the Board of Directors deems appropriate.

15.6 Insurance Trustee; Share of Proceeds. All insurance policies obtained by or on behalf of the Association shall be for the benefit of the Association, the Management Firm, the Unit Owners and their mortgagees, as their respective interests may appear, and shall provide that all proceeds covering losses to the Insured Property shall be paid to the Insurance Trustee, which may be designated by the Board of Directors and which, if so appointed, shall be a bank or trust company in Florida with trust powers, with its principal place of business in the State of Florida. The Insurance Trustee shall not be liable for payment of premiums, nor for the renewal or the sufficiency of policies, nor for the failure to collect any insurance proceeds. The duty of the Insurance Trustee shall be to receive such proceeds as are paid and to hold the same in trust for the purposes elsewhere stated herein, and for the benefit of the Unit Owners and their respective mortgagees in the following shares, but shares need not be set forth on the records of the Insurance Trustee:

(a) Insured Property. Proceeds on account of damage to the Insured Property shall be held by the Association for each Unit Owner as tenants in common on the basis of the fair market value of each Unit, relative to the other Units in the Condominium, immediately prior to the event of casualty (such fair market value shall be determined by an MAI-certified appraiser selected by the Board of Directors in its sole discretion); provided, however, that prior to any distributions to the Unit Owners, such proceeds shall first be distributed in accordance with the provisions of Section 15.7 herein and further provided that if the insured property so damaged includes property lying within the Residential Limited Common Elements, that portion of the proceeds allocable to the Residential Limited Common Elements shall be held in undivided shares for each Residential Unit Owner.

(b) Mortgagees. No mortgagee shall have any right to determine or participate in the determination as to whether or not any damaged property shall be reconstructed or repaired, and no mortgagee shall have any right to apply or have applied to the reduction of a mortgage debt any insurance proceeds, except for actual distributions thereof made to the Unit Owner and mortgagee pursuant to the provisions of this Declaration.

15.7 Distribution of Proceeds. Proceeds of insurance policies received by the Insurance Trustee shall be distributed to or for the benefit of the beneficial owners thereof in the following manner:

(a) Expenses of the Trust. All expenses of the Insurance Trustee shall be first paid or provision shall be made therefor.

(b) Reconstruction or Repair. If the damaged property for which the proceeds are paid is to be repaired or reconstructed, the remaining proceeds shall be paid to defray the cost thereof as elsewhere provided herein. Any proceeds remaining after defraying such costs shall be distributed to each Unit Owner, by check made payable jointly to such Unit Owner and its respective mortgagee(s), in accordance with the provisions of Section 15.6(a) herein.

(c) Failure to Reconstruct or Repair. If it is determined in the manner elsewhere provided that the damaged property for which the proceeds are paid shall not be reconstructed or repaired, the remaining proceeds shall be allocated among the beneficial owners as provided in Section 15.6(a) herein, and distributed to each Unit Owner by check made payable jointly to such Unit Owner and its respective mortgagee(s). If there is no mortgage on the Unit, all distributions shall be made directly to the Unit Owner.

(d) Certificate. In making distributions to Unit Owners and their mortgagees, the Insurance Trustee (if appointed) may rely upon a certificate of the Association made by its President and Secretary as to the names of the Unit Owners and their mortgagees and their respective shares of the distribution.

15.8 Association as Agent. The Association is hereby irrevocably appointed as agent and attorney-in-fact for each Unit Owner and for each owner of a mortgage or other lien upon a Unit and for each owner of any other interest in the Condominium Property to adjust all claims arising under insurance policies purchased by the Association and to execute and deliver releases upon the payment of claims.

15.9 Presumption as to Damaged Property. In the event of a dispute or lack of certainty as to whether damaged property constitutes a Unit(s) or Common Elements, such property shall be presumed to be Common Elements.

Section 16: Reconstruction or Repair After Fire or Other Casualty

16.1 Determination to Reconstruct or Repair. Subject to the immediately following subsection, in the event of damage to or destruction of the Insured Property as a result of fire or other casualty, the Board of Directors shall arrange for the prompt repair and restoration of the Insured Property, and the Insurance Trustee shall disburse the proceeds of all insurance policies to the contractors engaged in such repair and restoration in appropriate progress payments.

If 75% or more of the Insured Property is substantially damaged or destroyed and if Unit Owners owning 80% of the applicable interests in the Common Elements duly and promptly resolve not to proceed with the repair or restoration thereof and a Majority of Institutional First Mortgagees approve such resolution, the Condominium Property shall not be repaired and the net proceeds of insurance resulting from such damage or destruction shall be distributed to each Unit Owner, by check made payable to such Unit Owner and its respective mortgagee(s), in accordance with the provisions of Section 15.6(a) herein. Following such distribution of proceeds, the Condominium shall be terminated and the ownership of the Condominium Property shall be held by the formerly-titled Unit Owners in undivided interest as tenants-in-common, subject to and in accordance with the provisions of Section 21 hereof.

Whenever in this Section the words "promptly repair" are used, it shall mean that repairs are to begin not more than 60 days from the date the Insurance Trustee (if appointed) notifies the Board of Directors and Unit Owners that it holds proceeds of insurance on account of such damage or destruction sufficient to pay the estimated cost of such work, or not more than 90 days after the Insurance Trustee (if appointed) notifies the Board of Directors and the Unit Owners that such proceeds of insurance are insufficient to pay the estimated costs of such work. The Insurance Trustee (if appointed) may rely upon a certificate of the Association made by its President and Secretary to determine whether or not the damaged property is to be reconstructed or repaired.

16.2 Plans and Specifications. Any reconstruction or repair must be made substantially in accordance with the plans and specifications for the original improvements and the then applicable building and other codes; or if not, then in accordance with the plans and specifications approved by the Board of Directors and the then-applicable building and other codes.

16.3 Disbursement. The proceeds of insurance collected on account of a casualty, and the sums collected from Unit Owners on account of such casualty, shall constitute a construction fund which shall be disbursed in payment of the costs of reconstruction and repair in the following manner and order:

(a) Association - Lesser Damage. If the amount of the estimated costs of reconstruction and repair which are the responsibility of the Association is less than \$100,000.00, then the construction fund shall be disbursed in payment of such costs upon the order of the Board of Directors; provided, however, that upon request to the Insurance Trustee (if appointed) by an Institutional First Mortgagee which is a beneficiary of an insurance policy, the proceeds of which are included in the construction fund, such fund shall be disbursed in the manner provided below for the reconstruction and repair of major damage.

(b) Association - Major Damage. If the amount of the estimated costs of reconstruction and repair which are the responsibility of the Association is more than \$100,000.00, then the construction fund shall be disbursed in payment of such costs in the manner contemplated by subsection (a) above, but then only upon the further approval of an architect or engineer qualified to practice in Florida and employed by the Association to supervise the work.

(c) Unit Owners. If there is a balance of insurance proceeds after payment of all costs of reconstruction and repair that are the responsibility of the Association, this balance shall be distributed to each Unit Owner, by check made payable jointly to such Unit Owner and its respective mortgagee(s), in accordance with the provisions of Section 15.6(a) herein.

(d) Certificate. Notwithstanding the provisions herein, the Insurance Trustee shall not be required to determine whether or not sums paid by Unit Owners upon Assessments shall be deposited by the Association with the Insurance Trustee, nor to determine whether the disbursements from the construction fund are to be made upon the order of the Association alone or upon the additional approval of an architect, engineer or

otherwise, nor whether a disbursement is to be made from the construction fund, nor to determine whether surplus funds to be distributed are less than the Assessments paid by Unit Owners, nor to determine the payees nor the amounts to be paid. The Insurance Trustee may rely upon a certificate of the Association, made by its President and Secretary, as to any or all of such matters and stating that the sums to be paid are due and properly payable, and stating the names of the payees and the amounts to be paid.

16.4 Assessments. If the proceeds of the insurance are not sufficient to defray the estimated costs of reconstruction and repair to be effected by the Association, or if at any time during reconstruction and repair, or upon completion of reconstruction and repair, the funds for the payment of the costs of reconstruction and repair are insufficient, Assessments shall be levied against the Unit Owners in sufficient amounts to provide funds for the payment of such costs. Such Assessments on account of damage to the Insured Property shall be in proportion to all of the Owners' respective shares in the Common Elements, as determined by the Association.

16.5 Responsibilities of Unit Owners. If damage occurs to the Units, the maintenance and responsibility of which lies solely upon the respective Unit Owners, then each Unit Owner shall be solely responsible for all necessary reconstruction and repair to its respective Unit which reconstruction and repair shall be effected promptly and in accordance with guidelines established by the Board of Directors. Each Unit Owner shall have the absolute responsibility of applying insurance proceeds, arising as a result of flood, fire or other casualty damage to the Unit to the repair and/or reconstruction of such Unit; provided, however, that no Unit Owner shall have the responsibility of applying insurance proceeds to the repair and/or reconstruction of the respective Units if the Condominium is terminated in accordance with the provisions of Section 21 herein.

16.6 Benefit of Mortgagees. Certain provisions in this Section are for the benefit of mortgagees of Units and may be enforced by any of them.

Section 17: Condemnation

Any condemnation of any portion(s) of the Condominium Property shall be governed by the following provisions:

17.1 Deposit of Certain Condemnation Awards with Insurance Trustee. Condemnation awards pertaining to the taking of Common Elements shall be paid over by each Unit Owner to the Insurance Trustee for use as noted hereinafter in this Section. In the event the Unit Owner fails to turn over such award as required, the defaulting Unit Owner shall be charged the maximum interest which does not constitute usury under Florida law until such amount is fully paid.

Condemnation awards pertaining to the condemnation of Units shall not be the property of the Association.

17.2 Determination Whether to Continue Condominium. Whether the Condominium will be continued after condemnation will be determined in the manner provided for in Section 16 herein for determining whether damaged property will be reconstructed and repaired after casualty. For this purpose, the taking by eminent domain also shall be deemed to be a casualty.

17.3 Disbursement of Funds. If the Condominium is terminated following a condemnation, the proceeds of the awards pertaining to the condemnation of Common Elements will be deemed to be insurance proceeds and shall be owned and distributed in the manner provided with respect to the ownership and distribution of insurance proceeds if the Condominium is terminated after a casualty. If the Condominium is not terminated after condemnation, the size of the Condominium will be reduced and the property damaged by the taking will be made usable in the manner provided below. The proceeds of any such awards shall be used for these purposes and shall be disbursed in the manner provided for disbursement of funds by the Insurance Trustee after a casualty, or as elsewhere in this Section specifically provided.

17.4 Condemnation of Common Elements. Awards for the taking of portions of the Common Elements shall be used to render the remaining portion of the Common Elements usable in the manner approved by the Board of Directors of the Association; provided, however, that if the cost of such work shall exceed the balance of the funds from the awards for the taking, the work shall be approved in the manner elsewhere required for capital improvements to the Common Elements. The balance of the awards for the taking of Common Elements, if any, shall be distributed, after adjustments to these shares effected pursuant hereto by reason of the taking, to each Unit Owner by check made payable jointly to such Unit Owner and its respective mortgagee(s), in accordance with the provisions of Section 15.6(a) herein.

17.5 Condemnation of a Unit. If there is a taking of a Unit, the respective Unit Owner shall not be required to utilize any portion of the condemnation award with regard to reconstruction of the Unit. Following such taking of a Unit and the recording of a deed to the condemning authority, (1) the affected Unit Owner shall no longer have an ownership interest in the Unit or an undivided ownership interest in the Common Elements, and (2) such Unit Owner shall no longer be responsible for the payment of Common Expenses.

The following changes shall be made in the Condominium following a taking as described in this Section:

(a) Addition to Common Elements. The remaining portion of the Unit, if any, shall become part of the Common Elements and shall be placed in a condition allowing, to the extent possible, for use by all of the Unit Owners in the manner approved by the Board of Directors.

(b) Adjustment of Shares. The shares in the Common Elements, Common Expenses and Common Surplus appurtenant to the Units that continue as part of the Condominium shall be adjusted to distribute the shares in the Common Elements, Common Expenses and Common Surplus among the reduced number of Unit Owners (and among reduced Units). This distribution shall be determined by taking the total square footage of each Unit in proportion to square footage of the Units remaining in the Condominium.

(c) Assessments. In the event the Association does not have the funds necessary to alter the remaining portion of the condemned Unit for use as a part of the Common Elements, the additional funds for such

purposes shall be raised by Assessments against all of the Unit Owners who will continue as Owners of Units after the changes in the Condominium effected by the taking. The Assessments shall be made in proportion to the applicable percentage shares of those Owners after all adjustments to such shares effected pursuant hereto by reason of the taking.

17.6 Amendment of Declaration. The changes in Units, in the Common Elements and in the ownership of the Common Elements and share in the Common Expenses and Common Surplus that are effected by the taking shall be evidenced by an amendment to this Declaration that is only required to be approved by, and executed upon the direction of, a majority of all members of the Board of Directors.

Section 18: Occupancy and Use Restrictions

In order to provide for congenial occupancy of the Condominium Property and for the protection of the values of the Units, the use of the Condominium Property shall be restricted to and shall be in accordance with the following provisions:

Occupancy. Each Residential Unit shall be used only as a residence and/or a home office, all in accordance with any and all applicable county and state codes, ordinances and regulations. A Unit owned by an individual, corporation, partnership, trust or other fiduciary may only be occupied by the following persons, and such persons' families and guests: (i) the individual Unit Owner, (ii) an officer, director, stockholder or employee or such corporation, (iii) a partner or employee of such partnership, (iv) the fiduciary or beneficiary of such fiduciary, or (v) permitted occupants under an approved lease or sublease of the Unit (as describe below), as the case may be. Occupants of an approved lease or subleased Unit must be the following persons, and such persons' families and guests: (i) an individual lessee or sublessee, (ii) an officer, director, stockholder or employee of a corporate lessee or sublessee, or (iv) a fiduciary or beneficiary of a fiduciary lessee or sublessee.

Under no circumstances may more than one family reside in a Residential Unit at one time. "Families" or words of similar import used herein shall be deemed to include spouses, parents, parents-in-law, brothers, sisters, children and grandchildren. The Board of Administration shall have the power to authorize the use and occupancy of a Unit by persons in addition to those set forth above. The provisions of this Section shall not be applicable to Units used by the Developer for model apartments, sales offices, other offices or management services.

Other than the Developer, Residential Units Owners may not: (a) use or permit the use of his Unit except for purposes consistent with the laws of governing authorities having jurisdiction over the property; (b) permit or suffer anything to be done or kept in his Unit which would increase the insurance rates on his Unit or the Common Elements, or which will obstruct the view or interfere with the rights of other members or annoy them with unreasonable noises or otherwise; nor shall a member commit or permit any nuisance, immoral or illegal act in his Unit or on the Common Elements; (c) allow any rubbish, refuse, garbage or trash to accumulate in places other than the receptacles provided therefor, so that each Unit, the Common Elements and Limited Common Elements shall at all times remain in a clean and sanitary condition; (d) make any use of a Unit that violates any laws, ordinances and regulations of any governmental body having jurisdiction thereof; (e) play radios or tape recorders, except those with earphones, by the pool area; (f) remove any pool chairs and lounges from the pool deck area; (g) hold any parties on the pool deck or other Common Element without the approval of the Association.

All Residential Units Owners must: (a) in order to provide for proper safety, consume food or beverages at the pool only in the area designated by the Association; (b) provide proper identification to gain access to the pool; (c) accompany their guests to the pool at all times; (d) deposit their trash in the trash chute located on each floor.

Other than the Developer, all Units Owners must: (a) Promptly pay the Assessments levied by the Association; (b) maintain in a clean and sanitary manner and repair his Unit and all interior surfaces within or surrounding his Unit (such as the surfaces of the walls, ceilings, floors, etc.) whether or not a part of the Unit or Common Elements which are a part of the Unit, and maintain and repair the fixtures therein and pay for any utilities which are separately metered to his Unit; (c) Conform to and abide by the By-Laws and uniform rules and regulations in regard to the use of the Unit and Common Elements which may be adopted in writing from time to time by the Association, and to see that all persons using the Owner's property, by, through or under him do likewise; (d) Allow the Board of Directors or the agents and employees of the Association to enter any Unit for the purpose of maintenance, repair or replacement of any Common Elements or building system or for making emergency repairs which are necessary to prevent damage to the Common Elements or to another Unit or Units. If no key has been provided to the Association, then the expense of entry into a Unit for emergency purposes shall be borne by the Owner of the Unit; (e) Abide by any regulations regarding children as may be established by the Association, except that no regulations shall prohibit children from residing in or occupying a Unit; (f) Return the "Condominium Parcel" for the purpose of ad valorem taxes to the respective taxing authorities having jurisdiction over them for separate Assessment against his Condominium Parcel. For the purposes of ad valorem taxation, the interest of the Owner of a "Condominium Parcel" in his "Condominium Residence" and in the "Common Elements" shall be considered as a Residence. The value of said Residence shall be equal to the proportion or percentage of the value of the entire Condominium, including land and improvements, as has been assigned to said Residence in Exhibit "B" of the Declaration attached hereto as Exhibit A. The total of all said proportions or percentages equals the value of all of the land and improvements thereon; (g) use the parking spaces as provided herein; (h) provide the Association with at least one set of keys to their Unit(s), in case of emergency; (i) dress in proper attire, including shirts and shoes, when walking through Common Elements; (j) insure all personal property and fixtures in the residence with an "A" rated insurer according to Best's Rating guide. In addition, all Unit owners must carry liability coverage in an amount to be determined by the Board of Directors to protect against personal property damage to other residences.

Children. Children shall be the direct responsibility of their parents or legal guardian, including full supervision of them while within the Condominium Property and including full compliance by them of these restrictions and all rules and regulations of the Association. All children under 18 years of age must be accompanied by a responsible adult when entering and/or utilizing the recreational and other commonly used facilities.

Pets. Except for small domestic birds or fish, each Unit Owner (regardless of the number of joint owners) may maintain as household pets in his Unit, subject to the reasonable rules and regulations promulgated by the Association, either one domesticated dog, which, when fully grown shall not exceed the weight of 40 pounds, or two domesticated cats or two domesticated dogs, which, when fully grown will not exceed a combined weight of 80

pounds provided such pets are: (i) permitted to be so kept by applicable laws and regulations, (ii) not left unattended on balconies or any other area outside the Unit, (iii) generally not a nuisance (as determined by the Association) to residents of other Units or of neighboring buildings and (iv) not a pit bull or other such breed considered to be dangerous by the Board of Directors in their sole and absolute discretion. No animals of any kinds shall be kept under any circumstances in a unit, or allowed upon the Condominium Property, except by prior written consent of the Board of Administration of the Association. Neither the board nor the Association shall be liable for any personal injury, death or property damage resulting from a violation of the foregoing and any occupant of a Unit committing such violation shall fully indemnify and hold harmless the Board of Directors, the Developer, each Unit Owner and the Association in such regard. Pets are not permitted on any portion of the Recreation Deck. Any landscaping damage or other damage to the Common Elements and/or the Residential Limited Common Elements caused by a Unit Owner's pet must be promptly repaired by the Unit Owner. The Association retains the right to effect said repairs and charge the Unit Owner therefore. No pets shall be permitted in the Commercial Units or limited common element storage spaces, provided however, that nothing herein shall prohibit the guests, patrons or invitees of any Commercial Units from bringing their pets with them when patronizing a Commercial Unit or any tenant of any portion of a Commercial Unit. This Section pertaining to pets shall not be amended in any way which would cause those original Owners who brought pets meeting the requirements of this Section upon the Condominium Property and in the Units from keeping those pets.

Alterations Other than the Developer, Residential Units Owners may not do any construction or renovation without written notification to the Association at least twenty-four (24) hours in advance. The Association may reasonably restrict the time and manner of construction, except as it relates to the Developer. Work on residences, other than those held by Developer, may be commenced not earlier than 9:00 a.m. and all workers must be off of the premises by 5:00 p.m., Monday through Friday. No work on non-developer residences shall be done on Saturdays and Sundays without the prior written consent of the Association. Other than the Developer, Residence Owners must provide the Association with a \$500.00 security deposit prior to commencing construction or renovation. Additionally, while the Developer or Association maintains a construction dumpster on-site, all Residence Owners constructing or renovating their Residences shall use said dumpster for construction debris only and must pay to the Developer or Association a nonrefundable fee of up to \$200.00 per month for use of the dumpster while the owner's residence is under construction. No refuse from construction deliveries shall be placed in trash containers on a site not specifically designated for construction materials. Other than the Developer, Unit Owners must provide copies of proper permits, licenses, insurance certificates, plans and specifications to the Association before commencing with work. Owners must use only properly licensed and insured contractors and submit a copy of each contractor's insurance certificate to the Association prior to work commencing.

Other than the Developer, Residential Units Owners may not: (a) post any sign, advertisement or notice of any type on the Common Elements or his Unit, and erect no exterior antennas and aerials, except as provided in uniform regulations promulgated by the Association; (b) make any repairs to any plumbing, air conditioning systems or electrical wiring within a Residence, except by licensed plumbers, repairmen or electricians authorized to do such work by the management of the Association. Plumbing, air conditioning and electrical repairs within a Residence shall be paid for and be the financial obligation of the Owner of the Residence. The Association shall pay for and be responsible for plumbing, air conditioning repairs and electrical wiring within the Common Elements. The Association shall have the right to exclude any unauthorized repairmen from the Condominium; (c) extend, enclose or decorate any balconies, patios or terraces in any way whatsoever without the prior written consent of the Board of Directors. Should an owner elect to install hurricane shutters, the color, style and installation method must be approved in advance, in writing, by the Association; (d) except as otherwise provide herein, divide or subdivide a Residence for purpose of sale or lease, except that a Residential Unit may be combined with a contiguous Residential Unit and occupied as one dwelling Residential Unit; (e) hang any laundry, garments or other objects which are visible from outside of the Unit, except for draperies, blinds, shades or other suitable window coverings. Decorative window coverings shall not include any type of reflective film on any glass windows or doors; (f) make any alteration, decoration, repair, replacement or change of the Common Elements or to any outside or exterior portion of the building without the prior written consent of the Association, which consent can be granted or denied with or without cause; (g) replace and/or remove screens, canopies or other enclosures on balconies, patios or terraces or on other parts of the building, even though such areas may be Limited Common Elements, except with prior written approval of the Board of Directors. Notwithstanding anything contained herein to the contrary, pursuant to section 718.113(4), Florida Statutes, a Unit Owner is permitted to respectfully display a United States Flag and on Armed Forces Day, Memorial Day, Flag Day, Independence Day, and Veterans Day is permitted to display in a respectful way, portable, removable official flags, not larger than 4-1/2 feet by 6 feet, that represent the United States Army, Navy, Air Force, Marine Corps, or Coast Guard regardless of any declaration rules or requirements dealing with flags.

The Board of Directors shall have the right among other things to promulgate rules and regulations regarding soundproofing of floors in connection with the installation of floor coverings. Additionally, the Residential Unit Owner shall provide written proof of conformance with such regulations prior to installing any floor system in his/her/their Unit. The Board of Directors shall have the right to promulgate rules and regulations regarding the design of the Residential Units that affect the Common Elements of the Association directly or indirectly.

The foregoing shall specifically not apply to the owners of any Commercial Units. The Owners of the Commercial Units are expressly permitted (without requiring the consent of the Association or any Unit Owner or any other party other than any applicable governmental authorities to the extent that prior approval from them is required), to install on the exterior walls of such Owner's Commercial Unit and any Limited Common Element or Common Elements, balconies, terraces, patios, decks or other areas appurtenant to such signage, mechanical equipment, antennas, dishes, receiving, transmitting, monitoring or other equipment thereon as it may desire and may further make any alterations or improvements, in the Commercial Units Owner's sole discretion, to his or her Commercial Unit, Limited Common Elements or Common Elements. Any improvements and/or alterations made by a Commercial Units Owner, must however comply with all applicable governmental codes, ordinances and/or regulations.

The Developer shall be exempt from all provisions herein requiring the consent of the Association except for those which place restriction on (i) the presence of pets; (ii) occupancy of units based on age; (iii) the type of vehicles allowed on condominium property and (iv) requirements that leases or lessees be approved by the association in accordance with rule 61B-18.007 F.A.C. however, the Developer and its designees shall have the right to be exempt from any such parking restriction if the vehicle is engaged in any activity relating to construction, maintenance or marketing of Units, if such exemption is provided maintenance or marketing of Units, if such exemption is provided in the Condominium Documents.

Section 19: Selling, Leasing and Mortgaging of Units

Units may be made subject to mortgages without restrictions, but sales and leases thereof shall be subject to the provisions of this Section 19:

19.1 **Sales.** No conveyance of a Unit, by parties other than the Developer or Institutional Mortgagees, shall be valid unless a certificate executed and acknowledged by an officer of the Association, stating that all Assessments levied against such Unit have been paid in full, is recorded together with the instrument of conveyance. The Board of Directors shall furnish such certificate upon receipt from the Unit Owner of a request form (which will be prepared by the Association) setting forth the proposed purchaser's name, notice address and date of closing. Each new Owner receiving a conveyance from any party except the Developer shall notify the Association and the Management Firm promptly after becoming a new Owner by delivering a copy of his deed to the Unit to the Association and the Management Firm.

19.2 **Leases.** No lease of a Unit by the Owner thereof shall be for a period of less than six (6) months and no more than two (2) times per year; provided, however, and notwithstanding any provision to the contrary, the Developer may lease or rent any Unit owned by the Developer for any period of time and from time to time. No Unit Owner may lease or rent his Unit if delinquent in the payment of any Assessments. If all Assessments are paid up to date, a Unit Owner may rent or lease such Owner's Unit without further approval. However, the Unit Owner renting or leasing such Owner's Unit shall promptly notify the Association, or Management Firm of each renter and the term of such rental or lease. The sub-leasing or sub-renting of a Unit Owner's interest shall be subject to the same limitations as are applicable to the leasing or renting thereof. The Association shall have the right to require upon notice to all Unit Owners that a substantially uniform form of lease or sub-lease be used by all Unit Owners (including the Developer) intending to rent or lease after said notice and to provide such form as a Common Expense. Entire Units only may be rented, provided the occupancy is only by the lessee and his family and guests; no individual rooms may be rented.

Every lease shall specifically provide (or shall be automatically deemed to provide) that a material condition of the lease shall be the tenant's full compliance with the covenants, terms, conditions and restrictions of the Declaration (and all exhibits thereto) and with any and all rules and regulations adopted by the Association from time to time (before or after the execution of the lease). The Unit Owner will be jointly and severally liable with the tenant to the Association for any amount resulting from acts or omissions of tenants as determined in the sole discretion of the Association. A tenant of a Unit shall have all of the use rights in the Association Property and Common Elements otherwise readily available for use generally by Unit Owners and the Owner of the leased Unit shall not have such rights, except as a guest. This shall not, however, interfere with access rights of an Owner as landlord pursuant to applicable law.

Notwithstanding anything contained herein to the contrary, Commercial Units shall not be subject to any restrictions or limitations on leases or rentals, provided that they may only be used for lawful purposes.

19.3 **Continuing Liability.** The liability of the Unit Owner under this Declaration shall continue, notwithstanding the fact that he may have leased, rented or sub-let said interest as provided herein. Every purchaser, tenant or lessee shall take subject to this Declaration, the Articles of Incorporation, the By-Laws, and the management agreement, as well as the provisions of the Act.

19.4 **No Severance of Ownership.** No part of the Common Elements may be sold, conveyed or otherwise disposed of, except as an appurtenance to the Unit in connection with a sale, conveyance or other disposition of the Unit to which such interest is appurtenant, and any sale, conveyance or other disposition of a Unit shall be deemed to include that Unit's appurtenant interest in the Common Elements.

19.5 **Gifts and Devises, etc.** Any Unit Owner shall be free to convey or transfer such Owner's Unit by gift, to devise such Owner's Unit by will, or to have such Owner's Unit pass by intestacy, without restriction; provided, however, that each succeeding Unit Owner shall be bound by, and such Owner's Unit subject to, the provisions of this Section.

Section 20: Compliance and Default

Each Occupant and the Association shall be governed by and shall comply with the terms of this Declaration of Condominium and all exhibits annexed hereto, and the rules and regulations adopted pursuant to those documents, as the same may be amended from time to time. The Association (and Unit Owners, if appropriate) shall be entitled to the following relief in addition to the remedies provided by the Act:

20.1 **Negligence.** A Unit Owner shall be liable for the expense of any maintenance, repair or replacement made necessary by his negligence or by that of any member of his family or his or their guests, employees, agents or lessees, but only to the extent such expense is not met by the proceeds of insurance actually collected in respect of such negligence by the Association.

20.2 **Compliance.** In the event a Unit Owner fails to maintain a Unit or fails to cause such Unit to be maintained, or fails to observe and perform all of the provisions of the Declaration, the By-Laws, the Articles of Incorporation, applicable rules and regulations, or any other agreement, document or instrument affecting the Condominium Property or administered by the Association, in the manner required, the Association shall have the right to proceed in a court of equity to require performance and/or compliance, to impose any applicable fines or to sue in a court of law for damages. For purposes of this Declaration, the failure of an Occupant who is not a Unit Owner to comply with the terms and provisions of this Declaration shall not relieve the Unit Owner from liability and responsibility.

20.3 **Costs and Attorneys' Fees.** In any proceeding arising because of an alleged failure of a Unit Owner or the Association to comply with the requirements of the Act, this Declaration, the Articles of Incorporation, the By-Laws or the rules and regulations adopted pursuant to said documents, as the same may be amended from

time to time, the prevailing party shall be entitled to recover the costs of the proceeding and such reasonable attorneys' fees (including appellate attorneys' fees).

20.4 No Waiver of Rights. The failure of the Association or any Unit Owner to enforce any covenant, restriction or other provision of the Act, this Declaration, the Articles of Incorporation, the By-Laws or the rules and regulations adopted pursuant to said documents, as the same may be amended from time to time, shall not constitute a waiver of their right to do so thereafter.

Section 21: Termination of Condominium

The Condominium shall continue until (i) terminated by casualty loss, condemnation or eminent domain, as more particularly provided elsewhere in this Declaration, or (ii) such time as termination of the condominium form of ownership is authorized by a vote of Owners owning 100% of the Units and by the Primary Institutional First Mortgagee. Upon such termination, the former Condominium Property shall be subject to an action for partition by any Owner, and the net proceeds of sale shall be divided among all Owners in proportion to their respective interests in the Common Elements; provided, however, that no payment shall be made to an Owner until all mortgages and liens on his Unit, in the order of their priority, have been satisfied out of his share of such net proceeds. Upon such termination, all funds of the Association, including, but not limited to, reserves, but specifically excluding insurance proceeds and condemnation awards (which proceeds and awards shall be apportioned to the Unit Owners based upon the provisions of Sections 16.1 and 17.4, respectively), shall be divided among all Owners in proportion to their respective interests in the Common Elements; provided, however, that no payment shall be made to an Owner until all mortgages and liens on his Unit, in the order of their priority, have been satisfied out of his share of such net proceeds. The termination of the Condominium shall be effective upon a certificate of the Association, executed by its President and Secretary, certifying the basis of the termination being recorded among the public records of the County.

Section 22: Additional Rights of Mortgagees and Others

The following provisions are intended for the benefit of each holder of a first mortgage upon a Unit, and, to the extent that any other provisions of this Declaration conflicts with the following provisions, if at all, the following provisions shall control:

22.1 Upon request in writing, the Association shall furnish to each Institutional First Mortgagee of a Unit and any holder, insurer or guarantor of a first mortgage a written notice of any default by the Unit Owner of such Unit in the performance of such Unit Owner's obligations under this Declaration that has not been cured within 30 days.

22.2 Upon request in writing, each Institutional First Mortgagee of a Unit and any holder, insurer or guarantor of a first mortgage on a Unit shall have the right:

(a) to examine current copies of this Declaration, the By-Laws, rules and regulations and the books, records and financial statements of the Association during normal business hours;

(b) to receive, without any charge and within a reasonable time after such request, the annual audited financial statement which is prepared and distributed by the Association to the Unit Owners at the end of its fiscal year; provided, however, that in the event an audited financial statement is not available, the holders of 51% or more of the first mortgages in the Units shall be entitled to have such an audited statement prepared at their expense;

(c) to receive written notices of all meetings of the Association and to designate a representative to attend all such meetings;

(d) to receive written notice of any decision by the Unit Owners to make a material amendment to the Declaration, the By-Laws or the Articles of Incorporation;

(e) to receive written notice of any lapse, cancellation or material modification of any insurance policy or fidelity bond maintained by the Association; and

(f) to receive written notice of any action which would require the consent of a specified number of Institutional First Mortgagees.

22.3 No provision of this Declaration or the Articles of Incorporation or any similar instrument pertaining to the Condominium Property or the Units therein shall be deemed to give a Unit Owner or any other party priority over any rights of the Institutional First Mortgagees of Units pursuant to their mortgages in the case of distribution to Unit Owners of insurance proceeds or condemnation awards for losses to or a taking of the Units, and/or the Common Elements, or any portion thereof or interest therein. In such event, the holder of any first mortgage on a Unit shall be entitled, upon specific written request, to timely written notice of any such loss.

22.4 The consent of Owners holding at least 75% of the total votes in the Association and the approval of the holders of first mortgages on Units which represent at least 51% of the votes of Units that are subject to first mortgages shall be required to add or amend any material provisions of this Declaration which establish, provide for, govern or regulate any of the following:

(a) Voting rights;

(b) Increases in Assessments that raise the previously Assessment by more than 25%, Assessment liens or the priority of Assessment liens;

(c) Reductions in reserves for maintenance, repair and replacement of the Common Elements;

(d) Hazard or fidelity insurance requirements;

- (e) Rights to use of the Common Elements;
- (f) Responsibility for maintenance and repair of the Condominium Property;
- (g) Boundaries of any Unit;
- (h) The reallocation of interests in the Common Elements or Limited Common Elements or the rights to their use;
- (i) Convertibility of Units into Common Elements or of Common Elements into Units;
- (j) Leasing of Units;
- (k) Imposition of any right of first refusal or similar restriction on the right of a Unit Owner to sell, transfer, or otherwise convey his or her Unit; and
- (l) Any decision by the members of the Association to establish self-management and terminate the management responsibilities, duties and contractual obligations of the Management Firm, to the extent not superseded by the provisions of Section 718.302(1), Florida Statutes, in the event of conflict between such statute and this subsection;
- (m) The expansion or contraction of the Condominium Property, or the addition, annexation, or withdrawal of property to or from the Condominium;
- (n) Restoration or repair of the Condominium (after damage or partial condemnation) in a manner other than as provided in this Declaration; or
- (o) Any provisions which are for the express benefit of holders, insurers or guarantors of first mortgages on the Units.

22.5 Upon specific written request to the Association, each Institutional First Mortgagee of a Unit or holder, insurer or guarantor of a mortgage on a Unit shall be furnished notice in writing by the Association of any damage to or destruction or taking of the Common Elements if such damage or destruction or taking exceeds \$100,000.00 or if damage shall occur to a Unit in excess of \$10,000.00.

22.6 If any Unit or portion thereof or the Common Elements or any portion thereof is made the subject matter of any condemnation or eminent domain proceeding or is otherwise sought to be acquired by a condemning authority, then the holder, insurer or guarantor of any first mortgage on a Unit will be entitled to timely written notice, upon specific written request, of any such proceeding or proposed acquisition and no provisions of any document will entitle a Unit Owner or other party to priority over such holder with respect to the distribution to such Unit of the proceeds of any award or settlement.

22.7 Any holder of a first mortgage on a Unit who receives a written request to approve additions or amendments and fails to deliver or mail to the requesting party a negative response within thirty (30) days shall be deemed to have approved such request.

22.8 In the event professional management has been previously required by any holder, insurer or guarantor of a first mortgage on a Unit, any decision to establish self management by the Association shall require the prior consent of Unit Owners in accordance with Section 718.302(1), Florida Statutes.

22.9 As required by Section 718.110, Florida Statutes, any mortgagee consent required under this Section shall not be unreasonably withheld and shall otherwise be deemed to apply to the extent applicable.

Section 23: Disclaimer of Warranties

Pursuant to Section 718.203, Florida Statutes, the Developer is deemed to have granted the Purchaser of each Unit an implied warranty of fitness and merchantability for the purposes and uses intended as described in 718.203. To the extent permitted by law, the Developer hereby specifically disclaims any other warranties whether expressed or implied. Developer further disclaims any intent to have made any warranty or representation in connection with the Condominium Documents and disclosure materials except as specifically set forth therein, and no person shall rely upon any warranty or representation not specifically made herein. Any estimates of common expenses, taxes or other charges are believed to be accurate, but no warranty or guaranty is made or intended, nor may one be relied upon except where the same is specifically warranted or guaranteed.

All Unit Owners, by virtue of acceptance of title to their respective Units (whether from Developer or another party) shall be deemed to have automatically waived all incidental and consequential damages.

Unless specifically required by the Act or the applicable rules of the Florida Administrative Code, the Developer shall have no liability for any economic or non-economic damages to the Unit Owner. The only remedy available to the Unit Owner and/or Association shall be to compel the Developer to correct any construction defects that may be required by the Act or the applicable rules of the Florida Administrative Code.

AS TO SUCH WARRANTIES WHICH CANNOT BE DISCLAIMED, AND TO OTHER CLAIMS, IF ANY, WHICH CAN BE MADE AS TO THE AFORESAID MATTERS, ALL INCIDENTAL AND CONSEQUENTIAL DAMAGES ARISING THEREFROM ARE HEREBY DISCLAIMED.

ALL UNIT OWNERS, BY VIRTUE OF THEIR ACCEPTANCE OF TITLE TO THEIR RESPECTIVE UNITS (WHETHER FROM THE DEVELOPER OR ANOTHER PARTY), SHALL BE DEEMED TO HAVE AUTOMATICALLY WAIVED ALL OF THE AFORESAID DISCLAIMED WARRANTIES AND INCIDENTAL AND CONSEQUENTIAL DAMAGES.

Section 24: Arbitration

Disputes between a Unit Owner and the Association, as defined in Section 718.1255(1), Florida Statutes, involving Unit Owners, Associations and/or Tenants, shall be resolved by non-binding arbitration in accordance with the rules of the Division of Florida Land Sales, Condominiums and Mobile Homes. Without limiting the effect of the foregoing sentence, pursuant to Section 718.1255(4), Florida Statutes, prior to the institution of court litigation (whether to enforce an arbitration award or otherwise), the parties to a dispute shall petition the Division for non-binding arbitration. Pursuant to Rule 61B-45.015(1), F.A.C., parties to an arbitration proceeding are limited to unit owners, associations and tenants. Notwithstanding anything contained herein to the contrary, the remedies afforded by Sections 718.303 and 718.506, Florida Statutes, shall not be limited. Furthermore, this Section shall not impair the Association's access to the courts, as representative of the purchasers, pursuant to Section 718.111(3), Florida Statutes.

Section 25: Additional Provisions

25.1 Notices. All notices to the Association required or desired hereunder or under the By-Laws shall be sent by first class mail to the Association in care of its office at the Condominium, or to such other address as the Association may hereafter designate from time to time by notice in writing to all Unit Owners. Except as provided specifically in the Act, all notices to any Unit Owner shall be sent by first class mail to the address of such Unit Owner appearing in the Association's records at the time the notice is transmitted. Where a Unit is owned by more than one person, the Association shall provide notice, for meetings and all other purposes, to that one address which the Developer initially identifies for that purpose and thereafter as one or more of the Owners of the Unit shall so advise the Association in writing, or if no address is given or the Owners of the Unit do not agree, to the address provided in the deed record.

All notices to mortgagees of Units shall be sent by first class mail to their respective addresses, or such other address as may be designated by them from time to time, in writing to the Association.

All notices shall be deemed to have been given when mailed in a postage prepaid sealed wrapper, except notices of a change of address, which shall be deemed to have been given when received, or 5 business days after proper mailing, whichever shall first occur.

25.2 Interpretation. The Board of Directors shall be responsible for interpreting the provisions hereof and of any of the exhibits attached hereto. Such interpretation shall be binding upon all parties unless wholly unreasonable. An opinion of legal counsel to the Association, or the legal counsel having drafted this Declaration, that any interpretation adopted by the Association is not unreasonable shall conclusively establish the validity of such interpretation.

25.3 Binding Effect of Section 718.303, Florida Statutes. The provisions of Section 718.303(1), Florida Statutes, shall be in full force and effect and are incorporated herein. The Management Firm, for as long as the management agreement remains in effect, shall assist the Association in the prosecution of any action pursuant to the statute aforescribed.

25.4 Right of Developer to Add Recreational Facilities and Common Elements. If the Developer elects to add or expand any recreational facilities or any other portion of the Common Elements, the Developer shall pay all the expenses relating to the construction or the providing of such addition or expansion and shall record an amendment to this Declaration describing such property. The amendment shall be executed with the formalities of a deed and recorded in the public records of the County. No approval or action of the Association, Unit Owners or mortgagees shall be necessary for adding such additional Common Elements to condominium ownership. All costs of maintenance, repair and replacement relating to the addition or expansion of the recreational facilities or any other portion of the Common Elements shall be a Common Expense.

25.5 Right of Developer to Convey Property to the Association. The Developer hereby reserves the right to convey to the Association any real property lying contiguous to the Condominium Property free and clear of liens and encumbrances, including, but not limited to, wetlands or other parcels more suitable to become Association Property rather than Common Elements. All costs and expenses associated with such Association Property shall be Common Expenses. The Association shall be required to accept any such conveyance from the Developer.

25.6 Exhibits. There are hereby incorporated in this Declaration all materials contained in the exhibits annexed hereto, except that as to such exhibits, any conflicting provisions set forth therein as to their amendment, modification, enforcement and other matters shall control over those hereof.

25.7 Signature of President and Secretary. Wherever the signature of the President of the Association is required hereunder, the signature of a Vice-President may be substituted therefor, and, wherever the signature of the Secretary of the Association is required hereunder, the signature of an Assistant Secretary may be substituted therefor, provided that the same person may not execute any single instrument on behalf of the Association in 2 separate capacities.

25.8 Severability. The invalidity in whole or in part of any covenant or restriction, or any section, subsection, sentence, clause, phrase or word, or other provision of this Declaration, the exhibits annexed hereto, or applicable rules and regulations adopted pursuant to such documents, as the same may be amended from time to time, shall not affect the validity of the remaining portions thereof which shall remain in full force and effect.

25.9 Waiver. No provisions contained in this Declaration shall be deemed to have been waived by reason of any failure to enforce the same, without regard to the number of violations or breaches which may occur.

25.10 Ratification. Each Unit Owner, by reason of having acquired ownership (whether by purchase, gift, operation of law or otherwise), and each Occupant who is not a Unit Owner (by reason of such occupancy), shall be deemed to have acknowledged and agreed that all of the provisions of this Declaration, and the Articles of Incorporation, the By-Laws and applicable rules and regulations, are fair and reasonable in all material respects.

25.11 Gender: Plurality. For convenience and ease of reference, the third person singular impersonal form of pronoun "it" has been used herein without regard to the proper grammatical person or gender of the party being referred to. All such references shall be deemed to include the singular or plural person and the masculine, feminine or neuter gender, as required by the context.

25.12 Captions. The captions herein and in the exhibits annexed hereto are inserted only as a matter of convenience and for ease of reference and in no way define or limit the scope of the particular document or any provision thereof.

IN WITNESS WHEREOF, the Developer has caused this Declaration to be duly executed and its corporate seal to be hereunto affixed this 27th day of February, 2006.

WITNESSES:

[Signature]
Print Name: Yelisselle Aguirre
[Signature]
Print Name: JOSI A. PRIOR

GARDENS OF BRIDGEHAMPTON LLC,
a Delaware limited liability company

[Signature]
By: _____
Name: NEIL GREENBAUM
Title: VICE PRESIDENT

(Corporate Seal)

STATE OF Florida
COUNTY OF MIAMI-DADE

The foregoing instrument was acknowledged before me this 27th day of February, 2006, by Neil Greenbaum, a vice president member of GARDENS OF BRIDGEHAMPTON LLC, a Delaware limited liability company. He/She is personally known to me or has produced _____ as identification.

My Commission Expires:
(AFFIX NOTARY SEAL)



[Signature]
Name: Alina M. Allen
(Legibly Printed)
Notary Public, State of Florida
October 19, 2008
(Commission Number, if any)
00361074

CONSENT OF MORTGAGEE TO DECLARATION OF CONDOMINIUM FOR GARDENS OF BRIDGEHAMPTON, A CONDOMINIUM

THIS CONSENT is given as of the 9th day of February, 2006 on behalf of Merrill Lynch Capital, a Division of Merrill Lynch Business Financial Services Inc., a Delaware corporation ("Mortgagee"), being the owner and holder of that certain mortgage made by GARDENS OF BRIDGEHAMPTON LLC, a Delaware limited liability company ("Mortgagor"), dated the 27th day of December, 2005 and recorded in Official Records Book 12998, at Page 961, of the Public Records of Duval County, Florida as has been or may be amended from time to time, ("Mortgage").

WHEREAS, Developer has requested Mortgagee to consent to the recording of the Declaration of GARDENS OF BRIDGEHAMPTON, a Condominium (the Declaration).

NOW, THEREFORE, Mortgagee consents to the recordation of the Declaration.

Mortgagee makes no warranty or any representation of any kind or nature concerning the Declaration, any of its or their terms or provisions, or the legal sufficiency thereof, and disavows any such warranty or representation as well as any participation in the development of GARDENS OF BRIDGEHAMPTON, a Condominium (the "Condominium"), and does not assume and shall not be responsible for any of the obligations or liabilities of the developer contained in the Declaration or the prospectus, (if any) or other documents issued in connection with the promotion of the Condominium. None of the representations contained in the prospectus, (if any) or other documents shall be deemed to have been made by Mortgagee, nor shall they be construed to create any obligation on Mortgagee to any person relying thereon. This consent is limited to the purposes and requirements of Sections 718.104 and 718.403, Florida Statutes, and does not affect or impair the rights and remedies of Mortgagee as set forth in the Mortgage or in the Declaration.

WITNESSES:

Name: [Signature]
Print Name: [Print Name]
Name: [Signature]
Print Name: [Print Name]

MERRILL LYNCH CAPITAL, a Division of Merrill Lynch Business Financial Services Inc., a Delaware corporation
By: [Signature]
Name: [Print Name]
Title: [Print Title]

(SEAL)

STATE OF Georgia
COUNTY OF DeKalb

The foregoing instrument was acknowledged before me this 9th day of Feb, 2006, by Richard P. Kormanik as President of MERRILL LYNCH CAPITAL on behalf of said corporation. (He/she is personally known to me or has produced as identification.

My Commission Expires: 11/8/09
(AFFIX NOTARY SEAL)

[Signature]
Name: Grace E Kwan
(Legibly Printed)
Notary Public, State of Georgia

(Commission Number, if any)

GRACE E KWON
NOTARY PUBLIC, DeKALB COUNTY, GEORGIA
MY COMMISSION EXPIRES 11-8-2009

EXHIBIT "A"

GARDENS OF BRIDGEHAMPTON, A CONDOMINIUM

LEGAL DESCRIPTION, SURVEY, AFFIDAVIT OF SURVEYOR
AS TO CERTIFICATE OF SUBSTANTIAL
COMPLETION, PLOT PLAN, FLOOR PLANS FOR UNITS
AND GRAPHIC DESCRIPTION

EXHIBIT A TO THE DECLARATION OF CONDOMINIUM
GARDENS OF BRIDGEHAMPTON,
A CONDOMINIUM
CERTIFICATE

DESCRIPTION OF CONDOMINIUM UNITS:

EACH CONDOMINIUM UNIT CONSISTS OF THE SPACE BOUND BY A VERTICAL PROJECTION OF THE CONDOMINIUM UNIT BOUNDARY LINES SHOWN HEREIN AND BY THE HORIZONTAL PLANES AT THE FLOOR AND THE BOTTOM OF THE UNFINISHED CEILING.

THE CONDOMINIUM UNIT DIMENSIONS SHOWN SHALL BE MEASURED AT INTERIOR UNFINISHED SURFACES

DESCRIPTION OF COMMON ELEMENTS:

ALL LAND AND ALL PORTIONS OF THE IMPROVEMENTS SHOWN ON THESE PLANS NOT WITHIN ANY CONDOMINIUM UNIT OR LIMITED COMMON ELEMENT ARE PARTS OF THE COMMON ELEMENTS.

EACH CONDOMINIUM UNIT SHALL HAVE AS AN APPURTENANCE THERETO AN UNDIVIDED SHARE OF THE COMMON ELEMENTS AS THE SAME ARE DESCRIBED AND SET FORTH IN THE DECLARATION OF CONDOMINIUM.

DESCRIPTION OF LIMITED COMMON ELEMENTS:

THE PORCHES, CONCRETE PATIO SLABS AND BALCONIES APPURTENANT TO EACH CONDOMINIUM UNIT ARE LIMITED COMMON ELEMENTS AND ARE RESERVED FOR THE USE OF THE CONDOMINIUM UNIT TO WHICH THEY ARE APPURTENANT.

THE AIR CONDITIONING UNITS AND CONCRETE SLABS AS SHOWN HEREON ARE LIMITED COMMON ELEMENTS AND ARE APPURTENANT TO THE CONDOMINIUM UNITS INDICATED.

SURVEYOR'S CERTIFICATE:

I HEREBY CERTIFY THAT THE ATTACHED SURVEY NOTES AND PLANS MARKED SHEETS 1 THROUGH 78 OF EXHIBIT "A" OF THE DECLARATION OF GARDENS OF BRIDGEHAMPTON, A CONDOMINIUM ARE CORRECT AND THE THE CONSTRUCTION OF THE PLANNED IMPROVEMENTS, INCLUDING, BUT NOT LIMITED TO, LANDSCAPING, UTILITY SERVICES AND ACCESS TO THE UNITS, AND COMMON ELEMENT FACILITIES SERVING THE IMPROVEMENTS ARE SUBSTANTIALLY COMPLETE AS NOTED, SO THAT SUCH MATERIAL, TOGETHER WITH THE WORDING OF THE DECLARATION OF CONDOMINIUM OF GARDENS OF BRIDGEHAMPTON, A CONDOMINIUM RELATING TO MATTERS OF SURVEY, ARE AN ACCURATE REPRESENTATION OF THE LOCATION AND DIMENSIONS OF THE IMPROVEMENTS DESCRIBED; AND FURTHER THAT WITH SUCH MATERIAL THERE CAN BE DETERMINED THEREFROM THE IDENTIFICATION, LOCATION AND DIMENSIONS OF THE COMMON ELEMENTS, THE LIMITED COMMON ELEMENTS AND EACH CONDOMINIUM UNIT. DATED THIS 4th DAY OF OCTOBER, 2005.

Martin P. Rossi

MARTIN P. ROSSI
PROFESSIONAL SURVEYOR AND MAPPER
STATE OF FLORIDA REGISTRATION NO. 5857

NOT VALID WITHOUT THE SIGNATURE AND ORIGINAL RAISED SEAL OF A FLORIDA LICENSED SURVEYOR AND MAPPER.



South Florida Office: 1800 North Douglas Road - Suite 200
Pembroke Pines, Florida - 33024-3200
954-436-7000 - Fax: 954-436-8684
www.millerlegg.com

Certificate of Authorization L.B. 6680

DRAWN BY: J.L. & L.P. CHECKED BY: RDP

SKETCH OF BOUNDARY SURVEY

PROJECT NO.
05-00436

FILE NO.
11-1C-280

EXHIBIT A TO THE DECLARATION OF CONDOMINIUM
GARDENS OF BRIDGEHAMPTON,
A CONDOMINIUM

DESCRIPTION: (GARDENS OF BRIDGEHAMPTON, A CONDOMINIUM)

A PORTION OF THOSE CERTAIN LANDS DESCRIBED IN EXHIBIT A OF THE SPECIAL WARRANTY DEED RECORDED IN OFFICIAL RECORDS BOOK 12605, PAGE 987 OF THE PUBLIC RECORDS OF DUVAL COUNTY, FLORIDA, SAID PORTION BEING DESCRIBED AS:

ALL OF TRACT 5 OF "GATE PARKWAY WEST", ACCORDING TO THE PLAT THEREOF AS RECORDED IN PLAT BOOK 56, PAGE 97 OF THE PUBLIC RECORDS OF DUVAL COUNTY, FLORIDA, SAID TRACT BEING MORE FULLY DESCRIBED AS FOLLOWS:

BEGINNING AT THE SOUTHWESTERNMOST POINT OF TRACT 5 OF SAID PLAT, SAID POINT ALSO BEING THE SAME AS THE POINT OF BEGINNING OF THE LANDS DESCRIBED IN SAID SPECIAL WARRANTY DEED; THE FOLLOWING SEVEN (7) COURSES RUNNING ALONG THE COMMON BOUNDARY OF SAID TRACT 5 AND SAID SPECIAL WARRANTY DEED; (1) THENCE NORTH 28°55'48" WEST, 182.74 FEET; (2) THENCE NORTH 10°53'15" WEST, 700.82 FEET; (3) THENCE NORTH 45°06'36" WEST, 168.94 FEET TO A POINT ON THE SOUTHERLY RIGHT-OF-WAY OF GATE PARKWAY WEST, A VARIABLE WIDTH RIGHT-OF-WAY; (4) THENCE ALONG SAID RIGHT-OF-WAY LINE NORTH 88°17'08" EAST, 604.71 FEET; (5) THENCE CONTINUE ALONG SAID RIGHT-OF-WAY LINE NORTH 88°41'16" EAST 356.78 FEET; (6) THENCE CONTINUE ALONG SAID RIGHT-OF-WAY LINE NORTH 88°17'08" EAST 284.58 FEET TO THE NORTHEAST CORNER OF SAID TRACT 5 AND SAID DEED; (7) THENCE SOUTH 00°45'54" EAST, ALONG SAID COMMON BOUNDARY, A DISTANCE OF 164.59 FEET TO THE INTERSECTION OF THE NORTH LINE OF TRACT 7 OF SAID PLAT; THENCE SOUTH 89°14'06" WEST ALONG THE COMMON BOUNDARY OF SAID TRACTS 5 AND 7 OF SAID PLAT, A DISTANCE OF 20.00 FEET; THENCE SOUTH 00°45'54" EAST ALONG THE COMMON BOUNDARY OF SAID TRACTS, A DISTANCE OF 45.00 FEET; THENCE NORTH 89°14'06" EAST ALONG THE COMMON BOUNDARY OF SAID TRACTS TO AN INTERSECTION WITH THE AFORESAID COMMON BOUNDARY OF SAID TRACT 5 AND SAID SPECIAL WARRANTY DEED; THE FOLLOWING THREE (3) COURSES RUNNING ALONG THE AFORESAID COMMON BOUNDARY OF SAID TRACT 5 AND SAID SPECIAL WARRANTY DEED; (1) THENCE SOUTH 00°45'54" EAST A DISTANCE OF 911.75 FEET TO THE INTERSECTION OF THE NORTH RIGHT-OF-WAY LINE OF J. TURNER BUTLER BOULEVARD, A 220 FOOT WIDE RIGHT-OF-WAY; (2) THENCE NORTH 82°33'57" WEST, ALONG SAID NORTH RIGHT-OF-WAY LINE, A DISTANCE OF 923.59 FEET, TO A POINT ON A 612.96 FOOT RADIUS NON-TANGENT CURVE, CONCAVE TO THE NORTH, WHOSE RADIUS POINT BEARS NORTH 02°56'16" WEST; (3) THENCE WESTERLY ALONG SAID CURVE AND SAID NORTH RIGHT-OF-WAY LINE, THROUGH A CENTRAL ANGLE OF 00°24'10" AN ARC DISTANCE OF 4.31 FEET TO THE POINT OF BEGINNING, SAID ARC BEING SUBTENDED BY A CHORD BEARING AND DISTANCE OF SOUTH 87°15'49" WEST, 4.31 FEET.

SAID LANDS SITUATE, LYING, AND BEING IN THE CITY OF JACKSONVILLE, DUVAL COUNTY, FLORIDA AND CONTAINING 1,104,595 SQUARE FEET (25.358 ACRES) MORE OR LESS AND SUBJECT TO RIGHTS-OF-WAY, EASEMENTS, AND RESERVATIONS OF RECORD.



South Florida Office: 1800 North Douglas Road · Suite 200
 Pembroke Pines, Florida · 33024-3200
 954-436-7000 · Fax: 954-436-9684
 www.millerlegg.com

Certificate of Authorization L.B. 6680

SKETCH OF BOUNDARY SURVEY

PROJECT NO.

05-00436

FILE NO.

11-1C-280

EXHIBIT A TO THE DECLARATION OF CONDOMINIUM GARDENS OF BRIDGEHAMPTON, A CONDOMINIUM

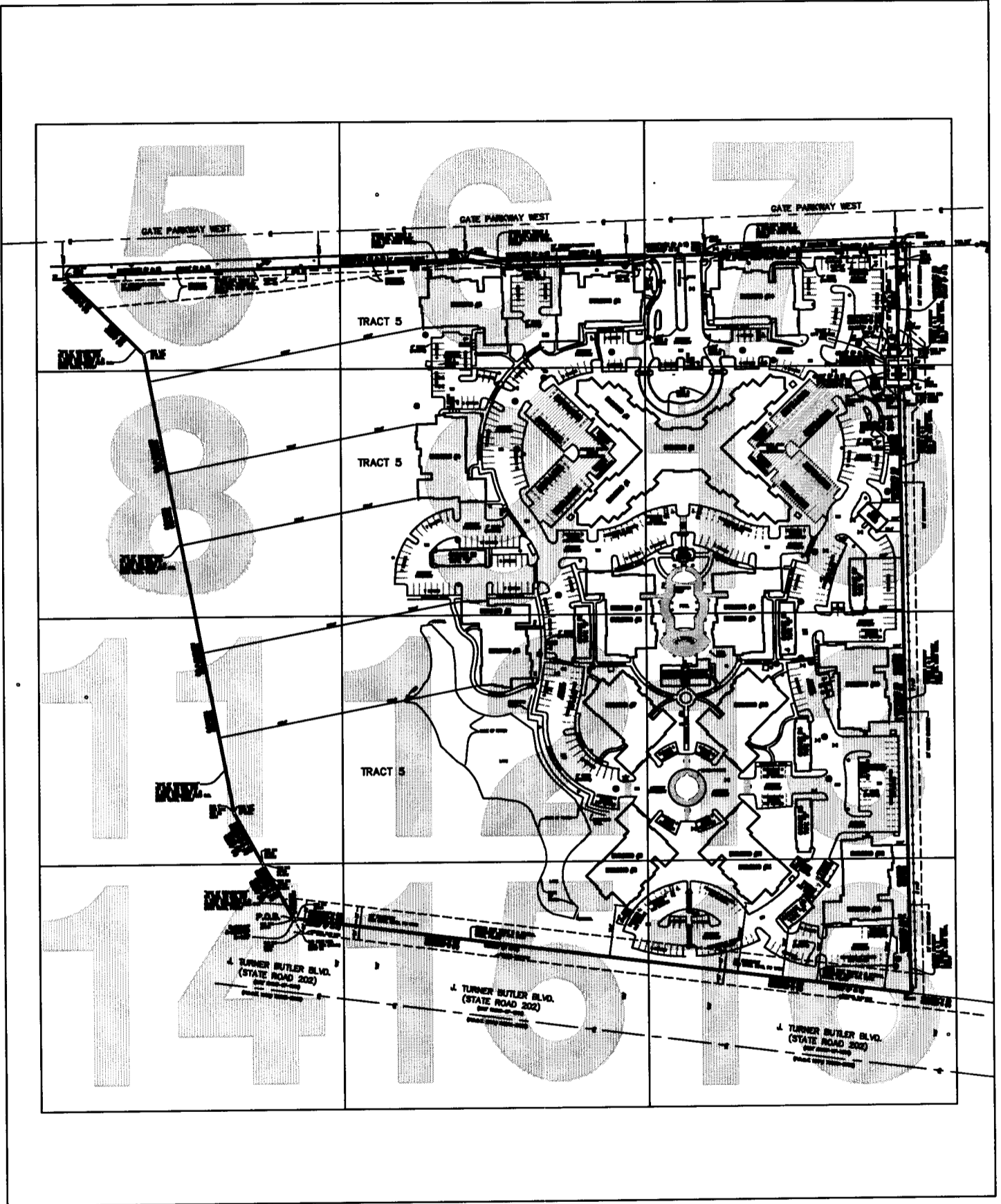

LOCATION MAP
N.T.S



MILLER LEGG

South Florida Office: 1800 North Douglas Road - Suite 200
Pembroke Pines, Florida - 33024-3200
954-436-7000 - Fax: 954-436-8664
www.millerlegg.com

Certificate of Authorization L.B. 6680

SKETCH OF BOUNDARY SURVEY

PROJECT NO.

05-00436

FILE NO.

11-1C-280

EXHIBIT A TO THE DECLARATION OF CONDOMINIUM GARDENS OF BRIDGEHAMPTON, A CONDOMINIUM

SURVEYOR'S NOTES:
SUBJECT PROPERTY WAS NOT ABSTRACTED BY THIS FIRM FOR EASEMENTS, RIGHTS-OF-WAY, RESERVATIONS OR OTHER MATTERS OF RECORD.

SCALE OF SOME FEATURES MAY BE EXAGGERATED FOR CLARITY.

EASEMENTS SHOWN HEREON ARE PER PLAT UNLESS OTHERWISE SHOWN.

VICINITY MAP
NOT TO SCALE

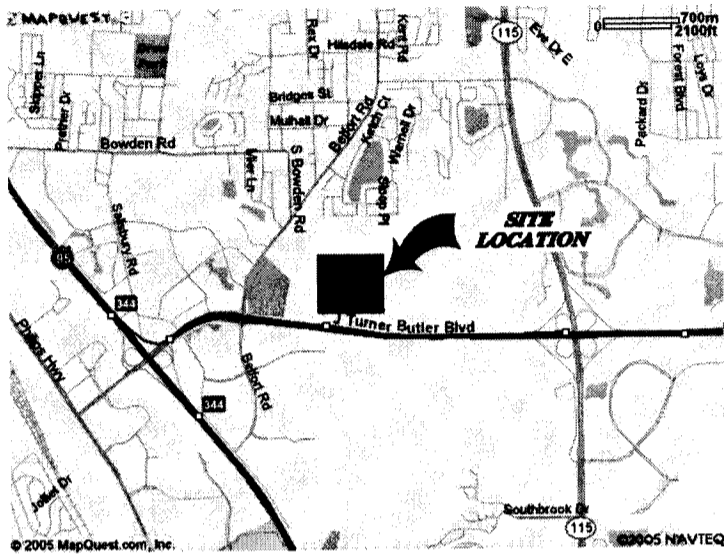

BEARING BASIS IS BASED ON THE PLAT BEARING OF N88°17'08"W ON THE MONUMENTED NORTH LINE OF TRACT 5 AS DELINEATED HEREON.
ELEVATIONS ARE RELATIVE TO NATIONAL GEODETIC VERTICAL DATUM OF 1929 AND BASED ON ST. JOHN'S WATER MANAGEMENT DISTRICT BENCHMARK # 98-035-0-01 DESCRIBED AS: A DISC IN CONCRETE SIDEWALK IN NORTHEAST CORNER OF INTERSECTION OF J. TURNER BUTLER BLVD. AND PHILIPS HWY (US 1).
ELEV. = 23.726'

- CATCH BASIN
- ☆ LIGHT POLE
- CONCRETE POWER POLE
- ⊙ MANHOLE
- ⊠ ELECTRIC SERVICE BOX
- ⊗ WATER VALVE
- ⊗ IRRIGATION CONTROL VALVE
- WATER METER
- ⊕ FIRE HYDRANT
- SIGN
- ⊠ BELL SOUTH RISER
- ⊠ CABLE TV RISER
- ⊠ BACKFLOW PREVENTER
- ⊠ JEA JEA CONCRETE SLAB
- DRAIN

- 1/2" IRON PIPE AND CAP
- NAIL AND DISC

ABBREVIATIONS:

- S/FIP = SET/FOUND IRON PIPE
- S/FN&D = SET/FOUND NAIL & DISC
- JEA-E/EE = JEA EASEMENT
- PVCF = POLYVINYL CHLORIDE FENCE
- CLF = CHAIN LINK FENCE
- ORV = OFFICIAL RECORDS VOLUME
- PB = PLAT BOOK
- PG = PAGE
- DB = DEED BOOK
- DCR = DUVAL COUNTY RECORDS
- (P) = PLAT
- (F) = FIELD CALCULATED BASED ON AN ADJUSTED TRAVERSE



South Florida Office: 1800 North Douglas Road · Suite 200
Pembroke Pines, Florida · 33024-3200
954-436-7000 · Fax: 954-436-8664
www.millerlegg.com

Certificate of Authorization L.B. 6680

SKETCH OF BOUNDARY SURVEY

PROJECT NO.
05-00436

FILE NO.
11-1C-280

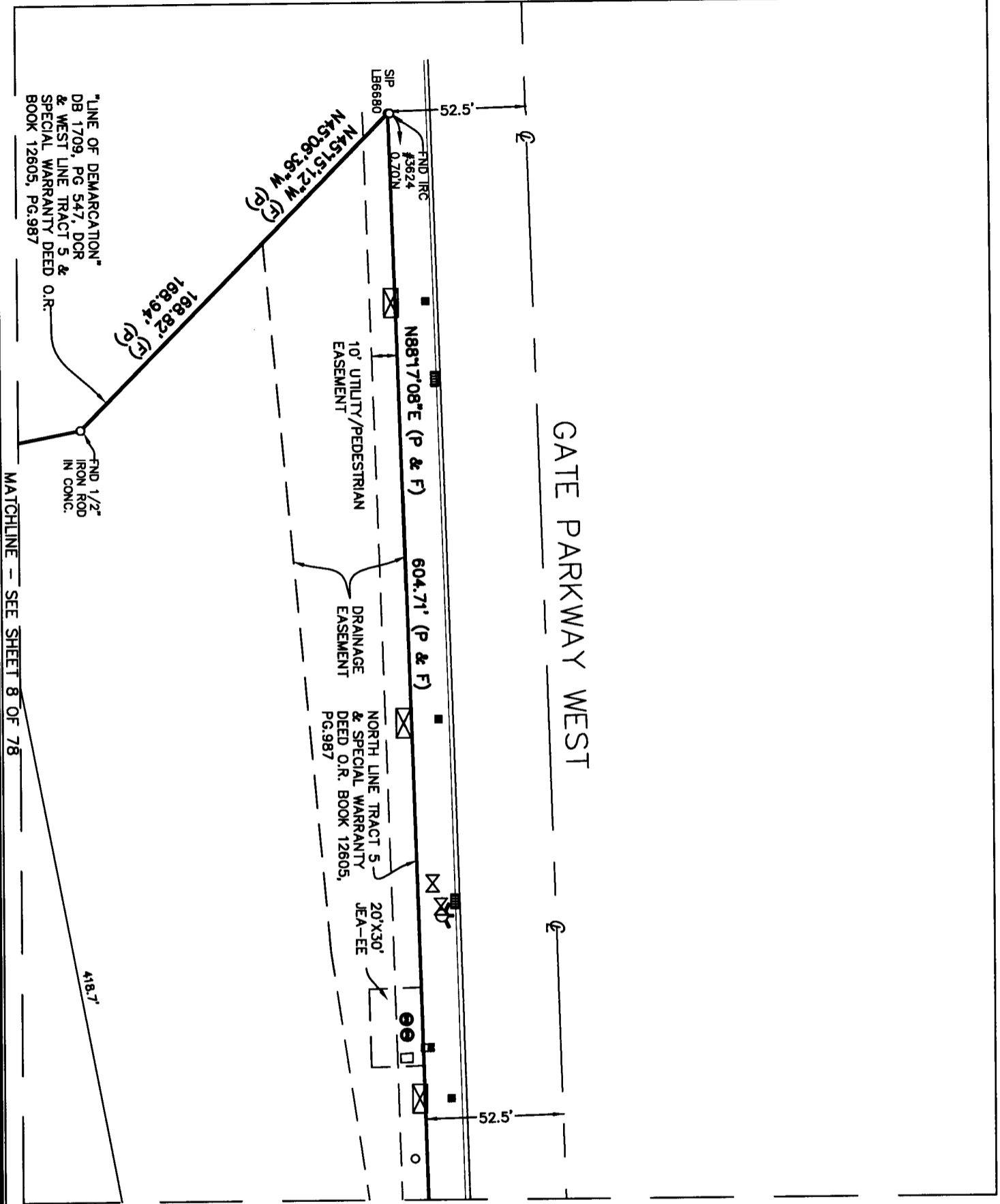

MATCHLINE - SEE SHEET 6 OF 78

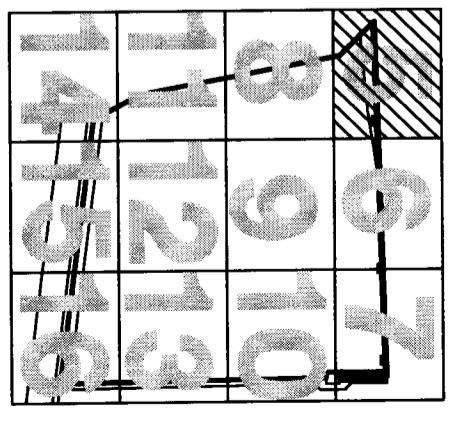
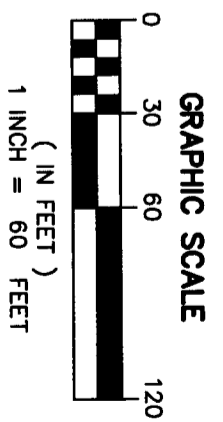

EXHIBIT A TO THE DECLARATION OF CONDOMINIUM
GARDENS OF BRIDGEHAMPTON,
A CONDOMINIUM.



MILLER LEGG
 South Florida Office: 1800 North Douglas Road · Suite 200
 Pembroke Pines, Florida · 33024-3200
 954-436-7000 · Fax: 954-436-8664
 www.millerlegg.com

Certificate of Authorization L.B. 6680

SKETCH OF BOUNDARY SURVEY

PROJECT NO. 05-00436	FILE NO. 11-1C-280
--------------------------------	------------------------------

MATCHLINE - SEE SHEET 5 OF 78

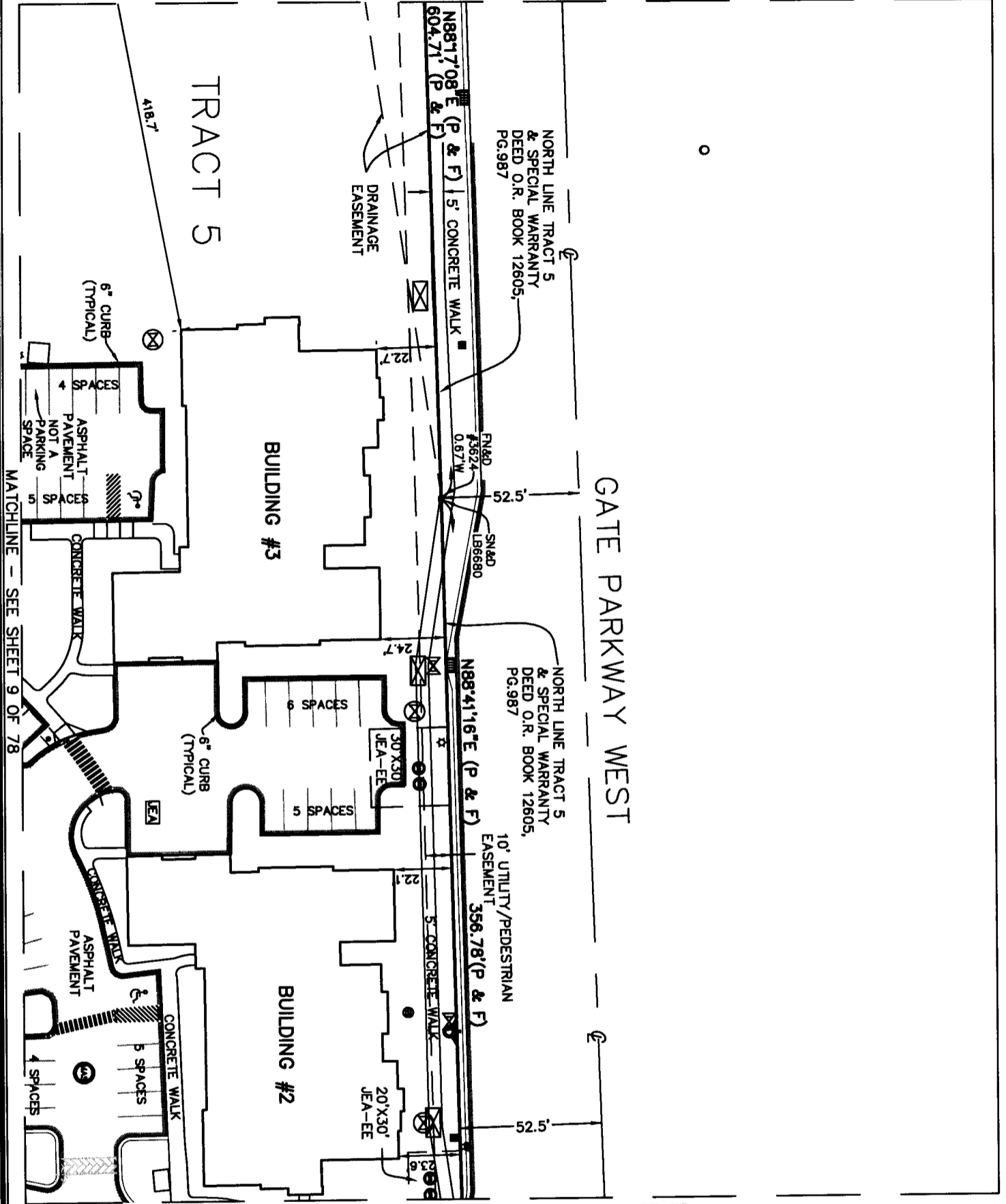

MATCHLINE - SEE SHEET 7 OF 78

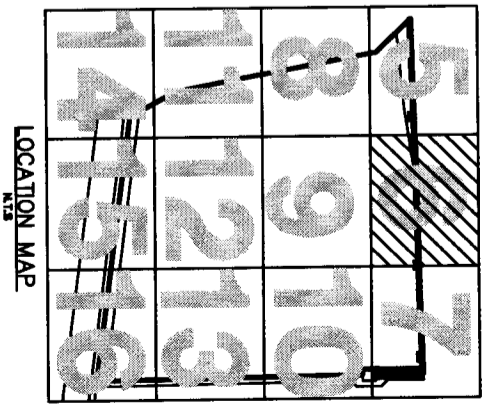

EXHIBIT A TO THE DECLARATION OF CONDOMINIUM
GARDENS OF BRIDGEHAMPTON,
A CONDOMINIUM



MILLER LEGG
 South Florida Office: 1800 North Douglas Road · Suite 200
 Pembroke Pines, Florida · 33024-3200
 954-436-7000 · Fax: 954-436-9664
 www.millerlegg.com

Certificate of Authorization L.B. 6680

SKETCH OF BOUNDARY SURVEY

PROJECT NO.
05-00436

FILE NO.
11-1C-280

MATCHLINE - SEE SHEET 6 OF 78

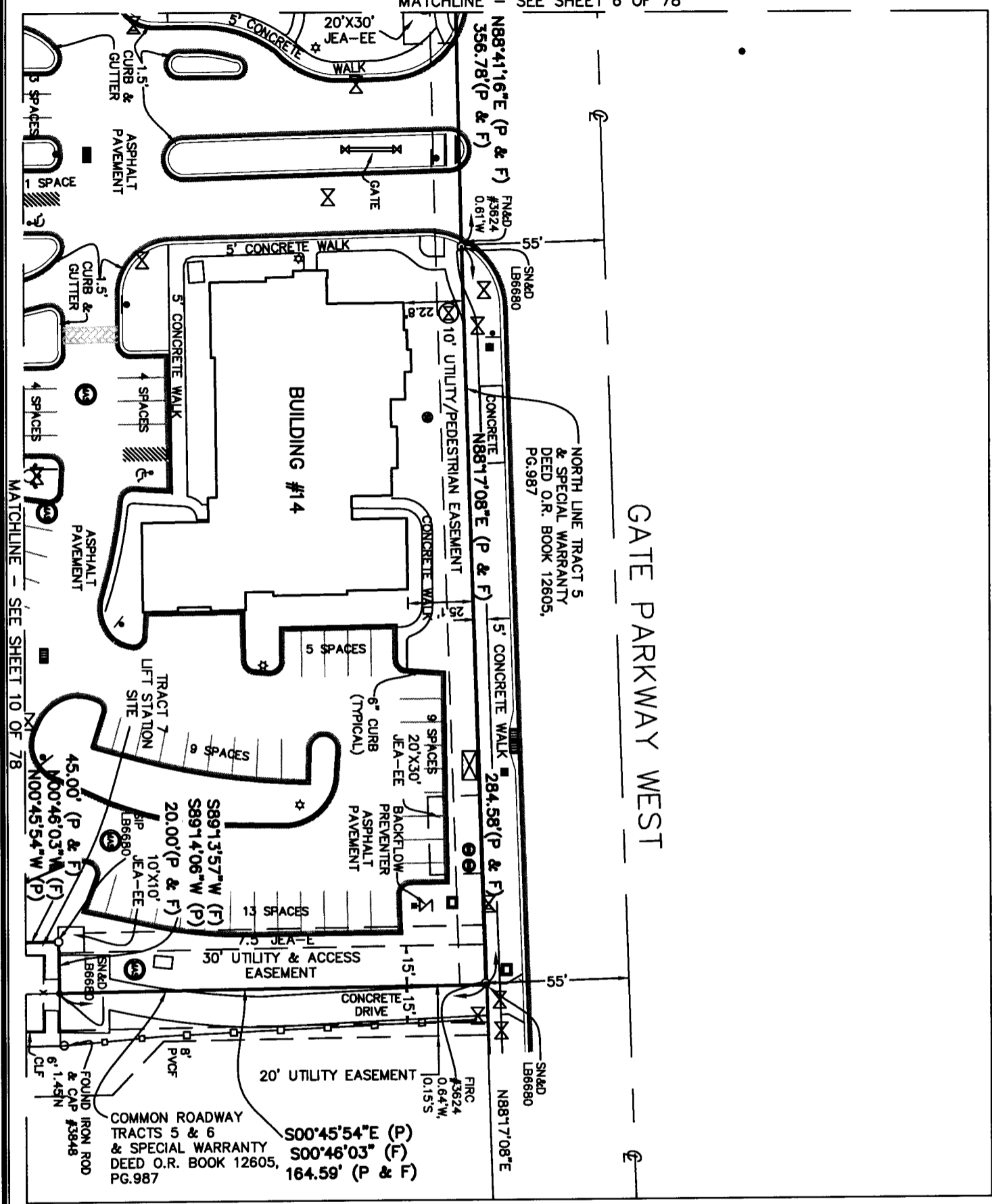

GATE PARKWAY WEST

NORTH LINE TRACT 5
& SPECIAL WARRANTY
DEED O.R. BOOK 12605,
PG.987

COMMON ROADWAY
TRACTS 5 & 6
& SPECIAL WARRANTY
DEED O.R. BOOK 12605,
PG.987

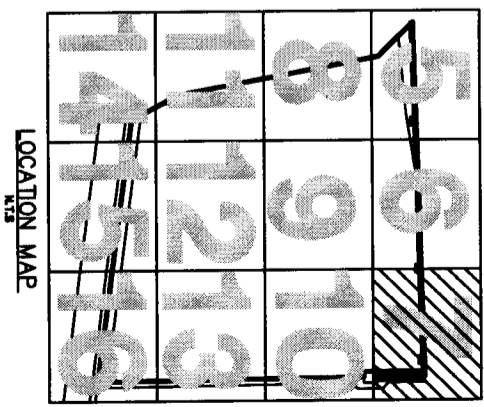

EXHIBIT A TO THE DECLARATION OF CONDOMINIUM
GARDENS OF BRIDGEHAMPTON,
A CONDOMINIUM



MILLER LEGG

South Florida Office: 1800 North Douglas Road · Suite 200
Pembroke Pines, Florida · 33024-3200
954-436-7000 · Fax: 954-436-8664
www.millerlegg.com

Certificate of Authorization L.B. 6680

SKETCH OF BOUNDARY SURVEY

PROJECT NO. **05-00436** FILE NO. **11-1C-280**

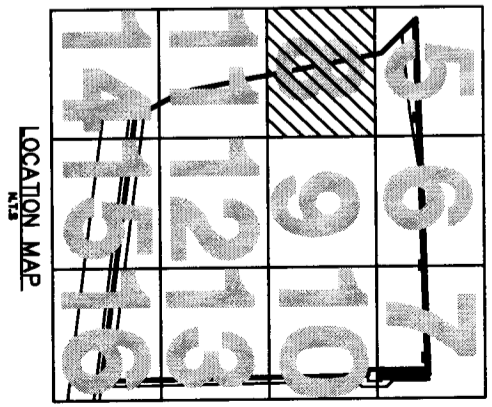
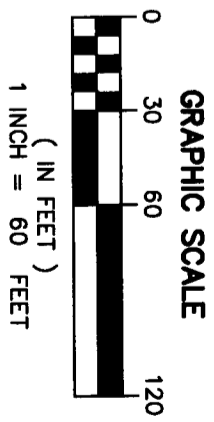
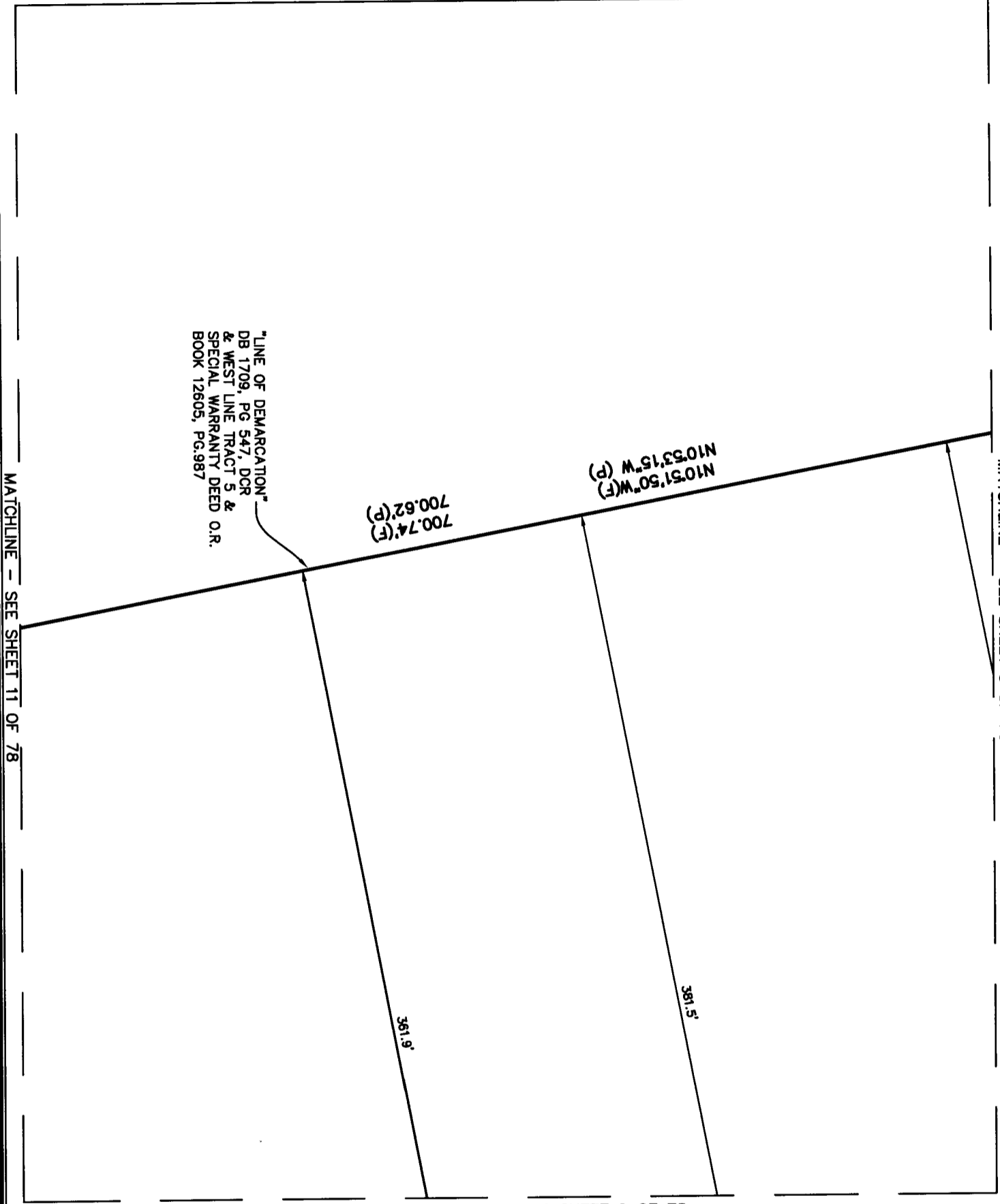

EXHIBIT A TO THE DECLARATION OF CONDOMINIUM
GARDENS OF BRIDGEHAMPTON,
A CONDOMINIUM

MILLER LEGG

South Florida Office: 1800 North Douglas Road · Suite 200
Pembroke Pines, Florida · 33024-3200
954-436-7000 · Fax: 954-436-8664
www.millerlegg.com

Certificate of Authorization L.B. 6680

SKETCH OF BOUNDARY SURVEY

PROJECT NO.
05-00436

FILE NO.
11-1C-280

MATCHLINE - SEE SHEET 8 OF 78

TRACT 5

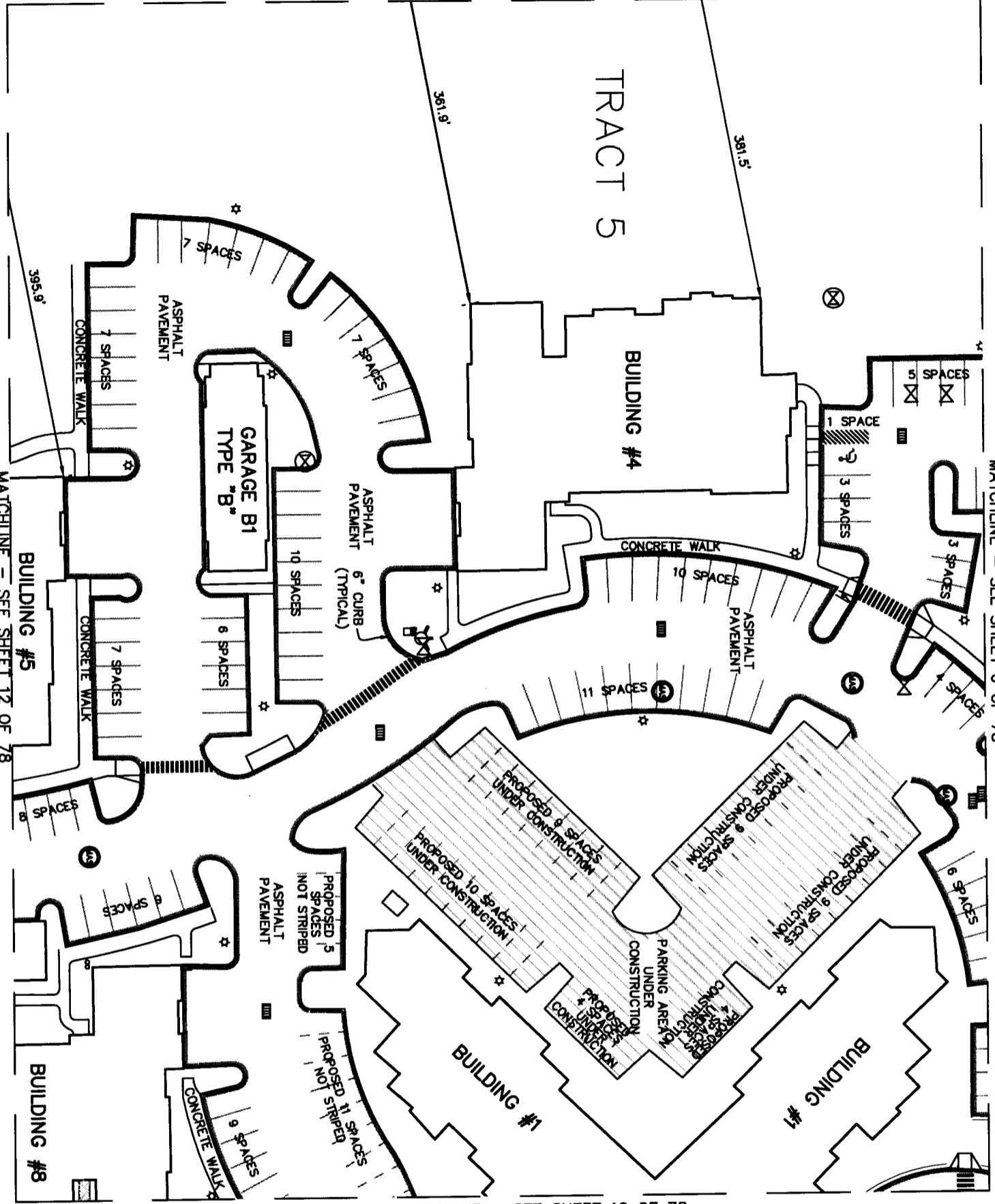

MATCHLINE - SEE SHEET 10 OF 78

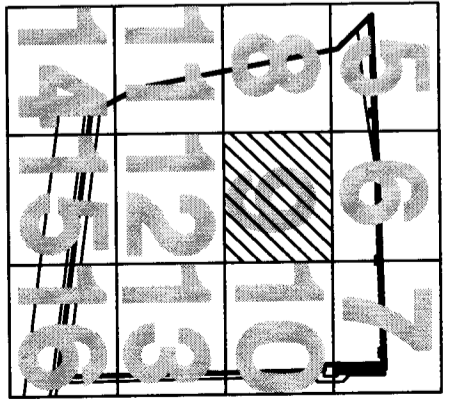

EXHIBIT A TO THE DECLARATION OF CONDOMINIUM
 GARDENS OF BRIDGEHAMPTON,
 A CONDOMINIUM



MILLER LEGG
 South Florida Office: 1800 North Douglas Road · Suite 200
 Pembroke Pines, Florida · 33024-3200
 954-436-7000 · Fax: 954-436-8664
 www.millerlegg.com

Certificate of Authorization L.B. 6680

SKETCH OF BOUNDARY SURVEY

PROJECT NO.
05-00436

FILE NO.
11-1C-280

MATCHLINE - SEE SHEET 9 OF 78

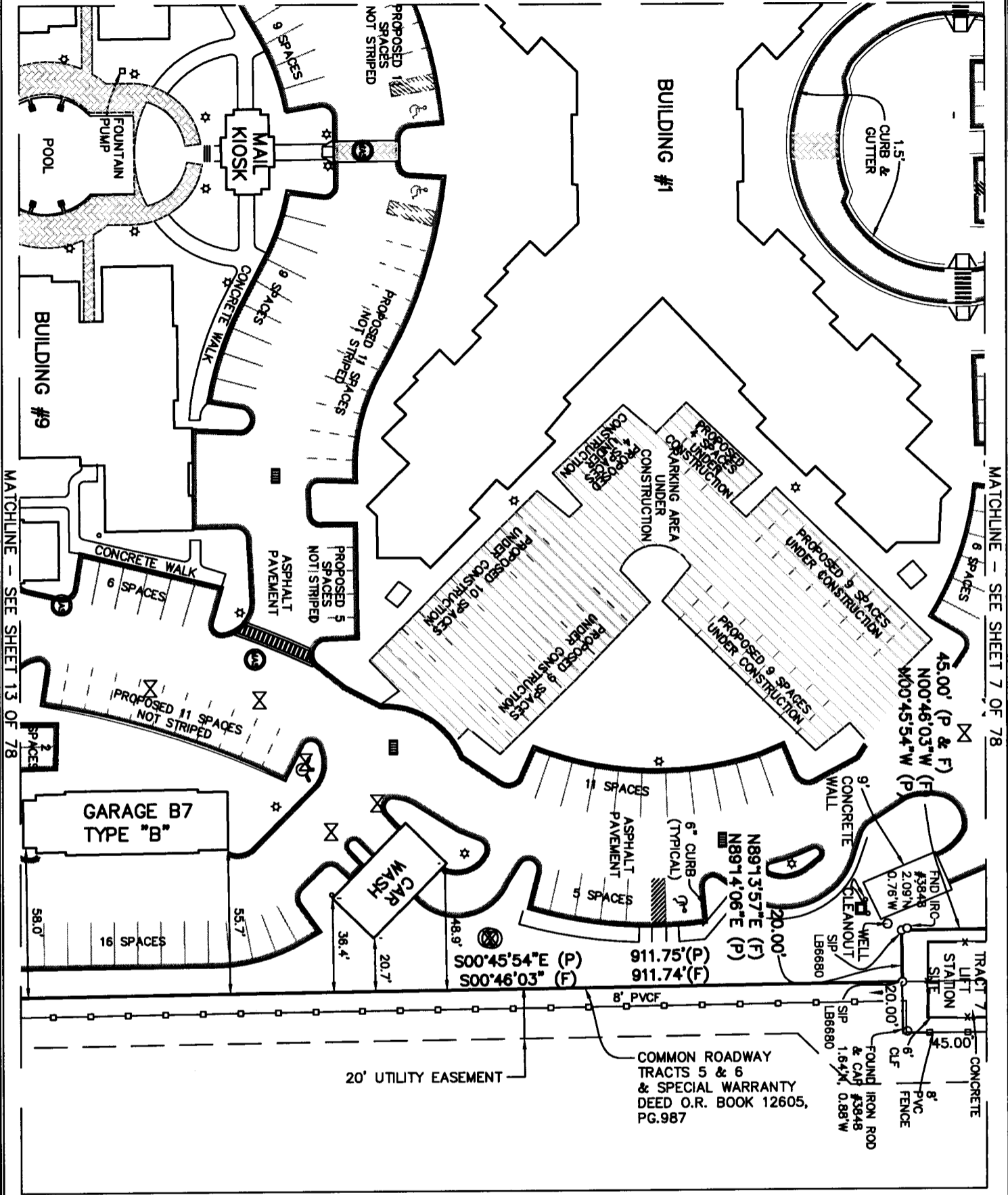

MATCHLINE - SEE SHEET 7 OF 78

MATCHLINE - SEE SHEET 13 OF 78

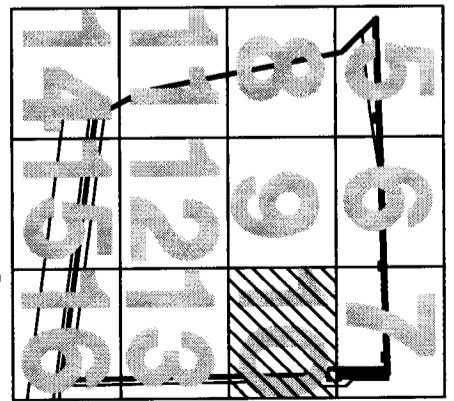
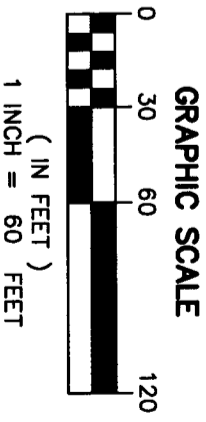

EXHIBIT A TO THE DECLARATION OF CONDOMINIUM
GARDENS OF BRIDGEHAMPTON,
A CONDOMINIUM



MILLER LEGG
 South Florida Office: 1800 North Douglas Road · Suite 200
 Pembroke Pines, Florida · 33024-3200
 954-436-7000 · Fax: 954-436-8664
 www.millerlegg.com

Certificate of Authorization L.B. 6680

SKETCH OF BOUNDARY SURVEY

PROJECT NO.
05-00436

FILE NO.
11-1C-280

MATCHLINE - SEE SHEET 14 OF 78

MATCHLINE - SEE SHEET 8 OF 78

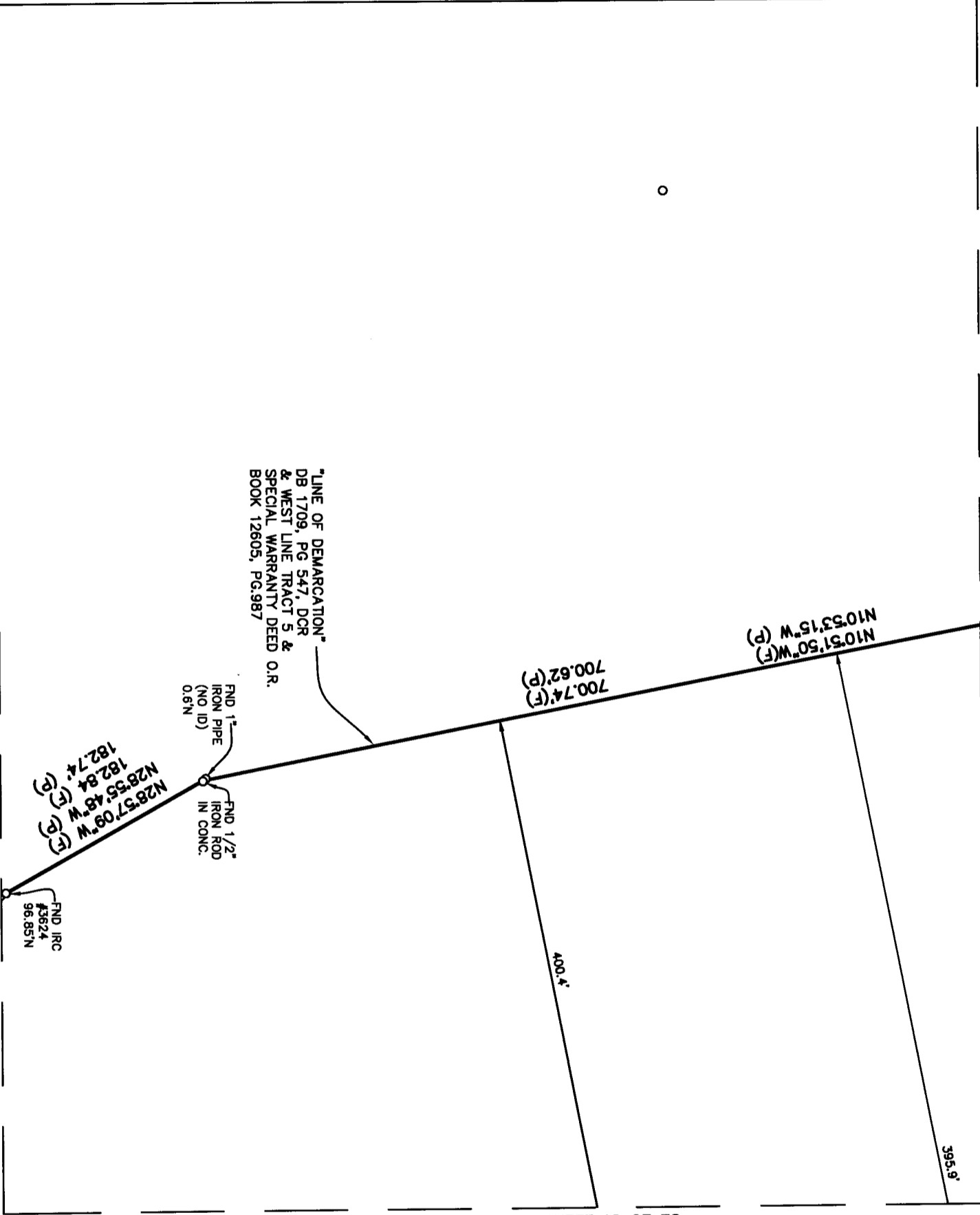

"LINE OF DEMARCATION"
 DB 1709, PG 547, DCR
 & WEST LINE TRACT 5 &
 SPECIAL WARRANTY DEED O.R.
 BOOK 12605, PG.987

FND 1 1/2"
 IRON ROD
 IN CONC.
 FND 1"
 IRON PIPE
 (NO ID)
 0.61N

FND IRC
 #3624
 96.85N
 N28°55'48"W (P)
 182.84 (P)
 182.74' (P)

MATCHLINE - SEE SHEET 12 OF 78

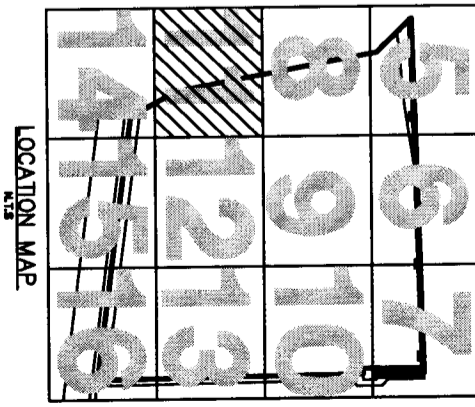

EXHIBIT A TO THE DECLARATION OF CONDOMINIUM
 GARDENS OF BRIDGEHAMPTON,
 A CONDOMINIUM



MILLER LEGG
 South Florida Office: 1800 North Douglas Road · Suite 200
 Pembroke Pines, Florida · 33024-3200
 954-436-7000 · Fax: 954-436-8864
 www.millerlegg.com

Certificate of Authorization L.B. 6680

SKETCH OF BOUNDARY SURVEY

PROJECT NO.
05-00436

FILE NO.
11-1C-280

MATCHLINE - SEE SHEET 11 OF 78

TRACT 5

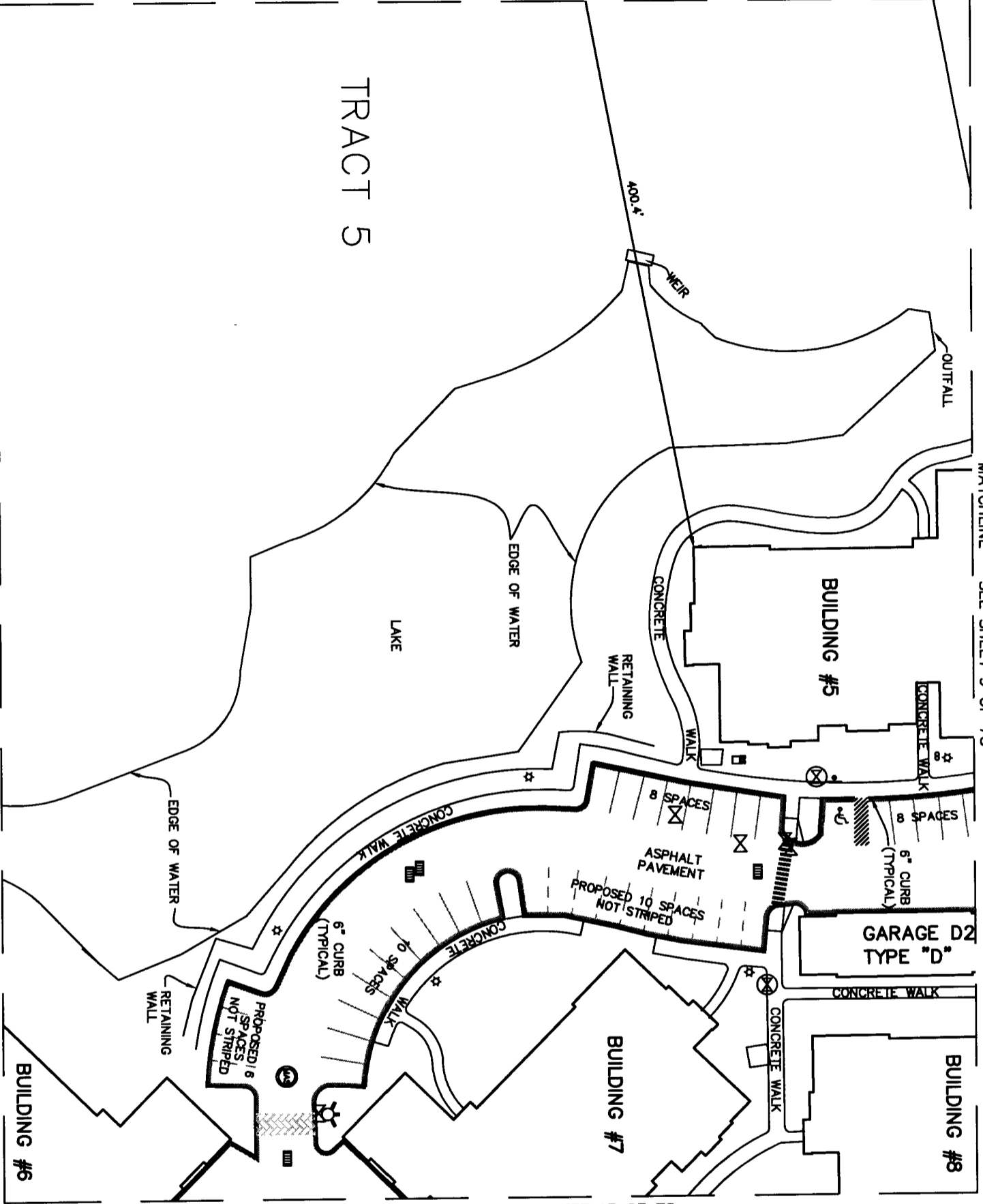

MATCHLINE - SEE SHEET 9 OF 78

MATCHLINE - SEE SHEET 15 OF 78

MATCHLINE - SEE SHEET 13 OF 78

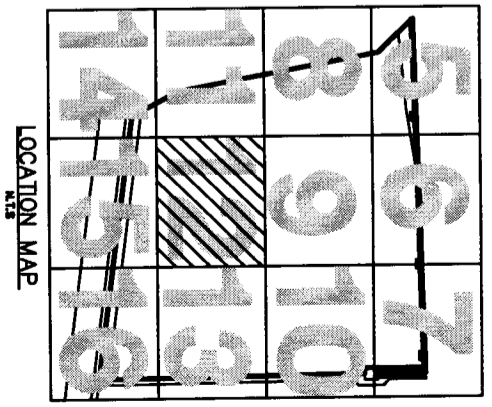
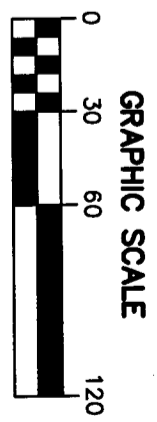

EXHIBIT A TO THE DECLARATION OF CONDOMINIUM
GARDENS OF BRIDGEHAMPTON,
A CONDOMINIUM

Certificate of Authorization L.B. 6680

SKETCH OF BOUNDARY SURVEY

PROJECT NO.
05-00436

FILE NO.
11-1C-280

MILLER LEGG

South Florida Office: 1800 North Douglas Road · Suite 200
Pembroke Pines, Florida · 33024-3200
954-436-7000 · Fax: 954-436-8664
www.millerlegg.com

MATCHLINE - SEE SHEET 12 OF 78

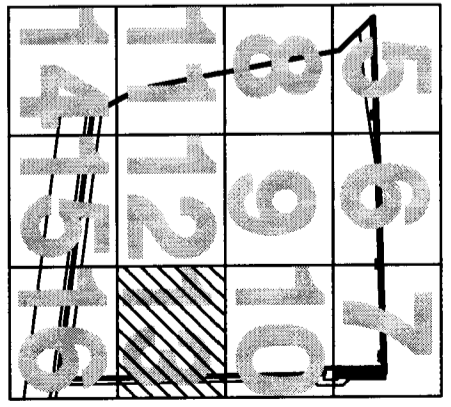
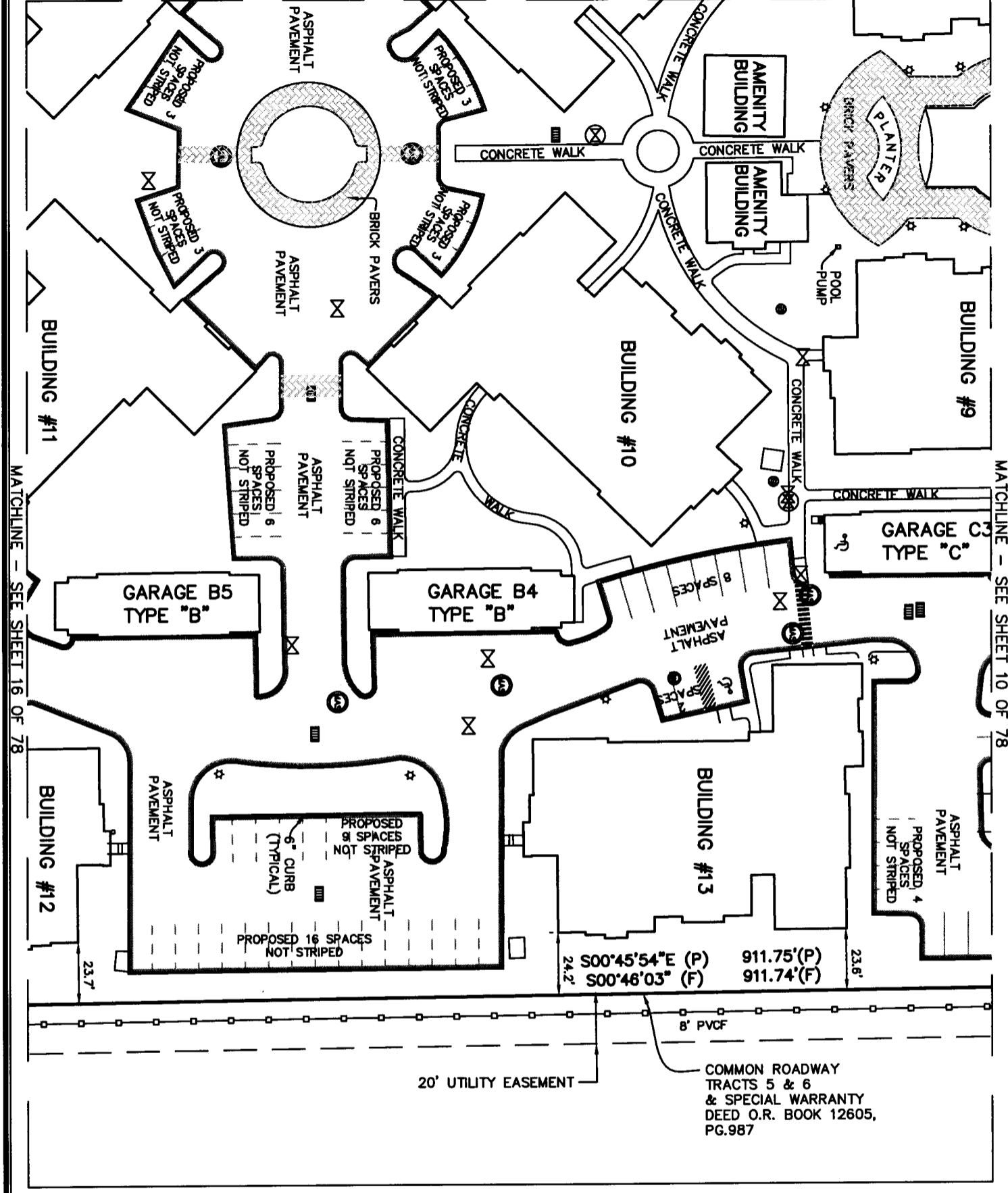
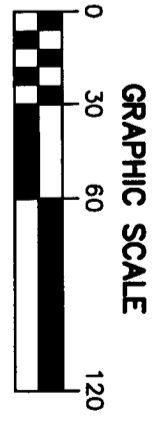

EXHIBIT A TO THE DECLARATION OF CONDOMINIUM
 GARDENS OF BRIDGEHAMPTON,
 A CONDOMINIUM



MILLER LEGG
 South Florida Office: 1800 North Douglas Road · Suite 200
 Pembroke Pines, Florida · 33024-3200
 954-436-7000 · Fax: 954-436-8664
 www.millerlegg.com

Certificate of Authorization L.B. 6680

SKETCH OF BOUNDARY SURVEY

PROJECT NO.
05-00436

FILE NO.
11-1C-280

MATCHLINE - SEE SHEET 11 OF 78

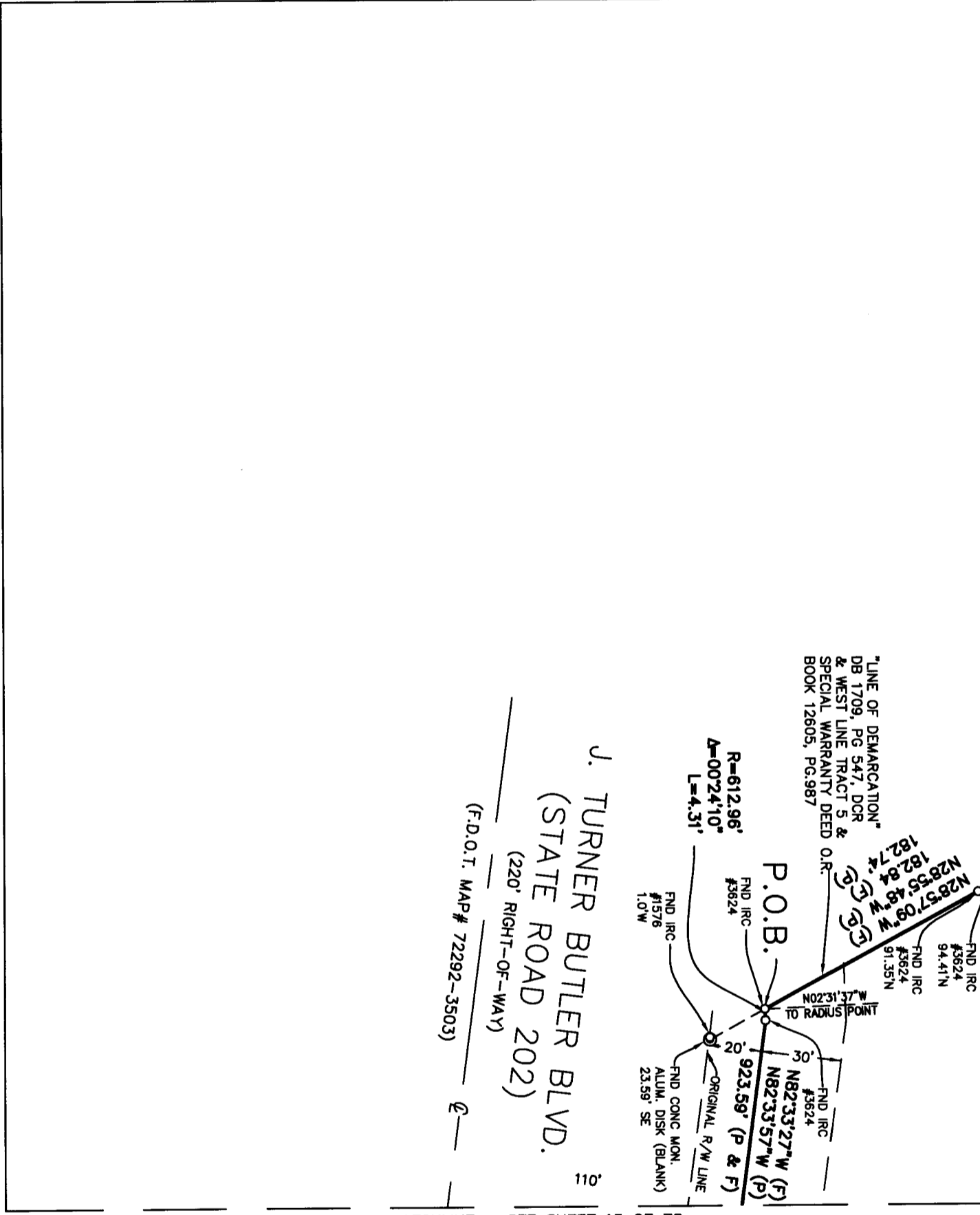

MATCHLINE - SEE SHEET 15 OF 78

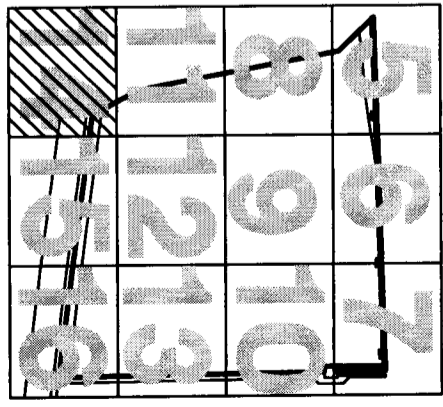
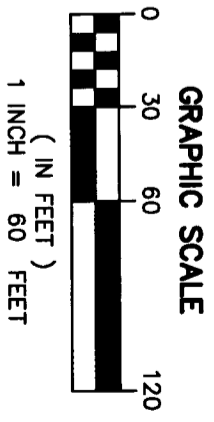

EXHIBIT A TO THE DECLARATION OF CONDOMINIUM
GARDENS OF BRIDGEHAMPTON,
A CONDOMINIUM



MILLER LEGG
South Florida Office: 1800 North Douglas Road · Suite 200
Pembroke Pines, Florida · 33024-3200
954-436-7000 · Fax: 954-436-8864
www.millerlegg.com

Certificate of Authorization L.B. 6680

SKETCH OF BOUNDARY SURVEY

PROJECT NO.
05-00436

FILE NO.
11-1C-280

MATCHLINE - SEE SHEET 14 OF 78

MATCHLINE - SEE SHEET 12 OF 78

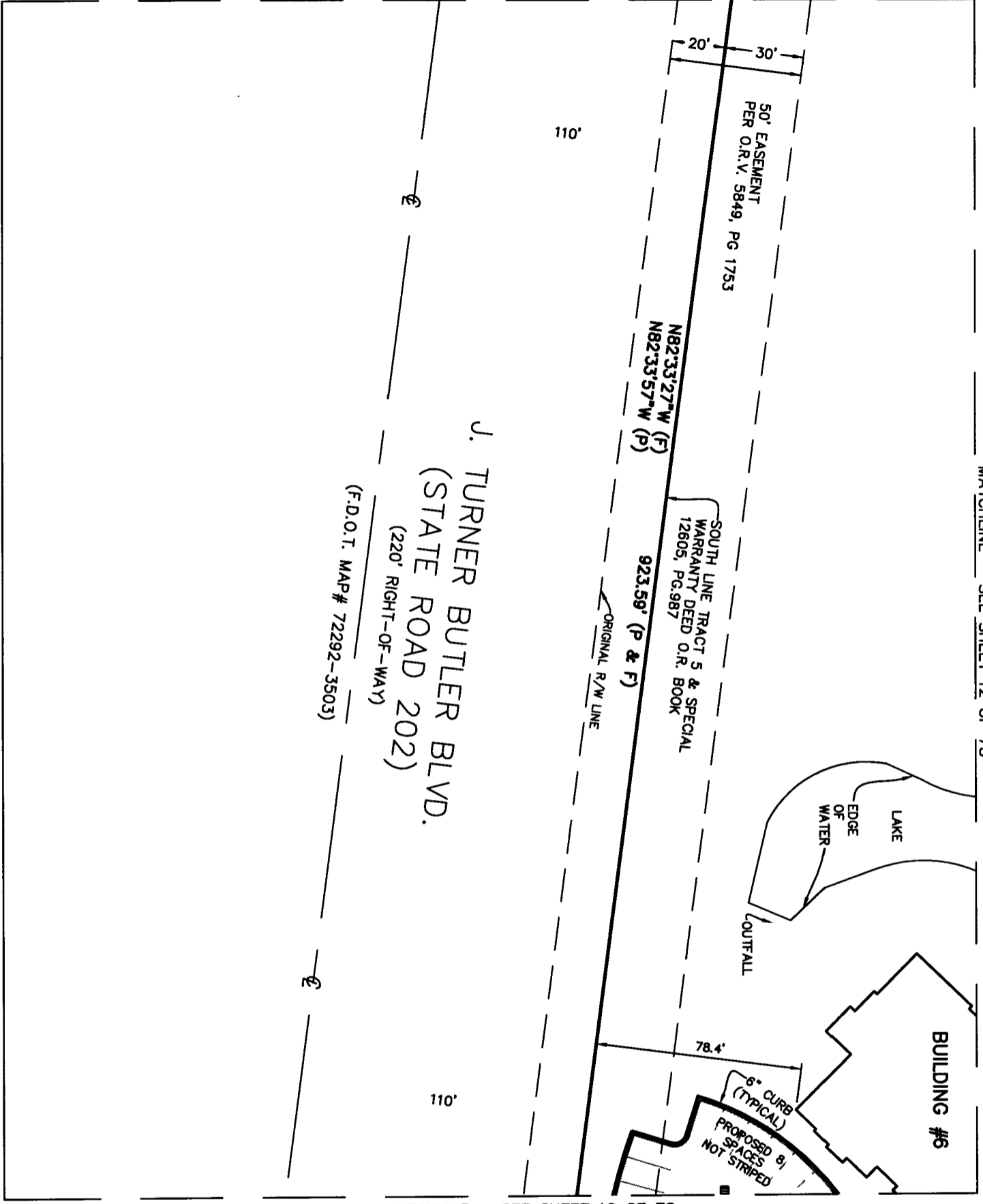

MATCHLINE - SEE SHEET 16 OF 78

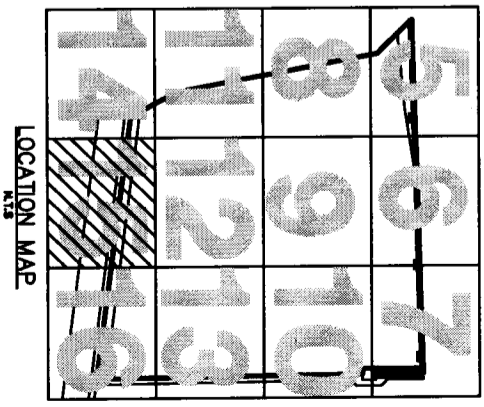
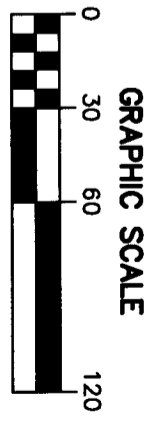

EXHIBIT A TO THE DECLARATION OF CONDOMINIUM
GARDENS OF BRIDGEHAMPTON,
A CONDOMINIUM



MILLER LEGG

South Florida Office: 1800 North Douglas Road · Suite 200
Pembroke Pines, Florida · 33024-3200
954-436-7000 · Fax: 954-436-8664
www.millerlegg.com

Certificate of Authorization L.B. 6680

SKETCH OF BOUNDARY SURVEY

PROJECT NO.
05-00436

FILE NO.
11-1C-280

MATCHLINE - SEE SHEET 15 OF 78

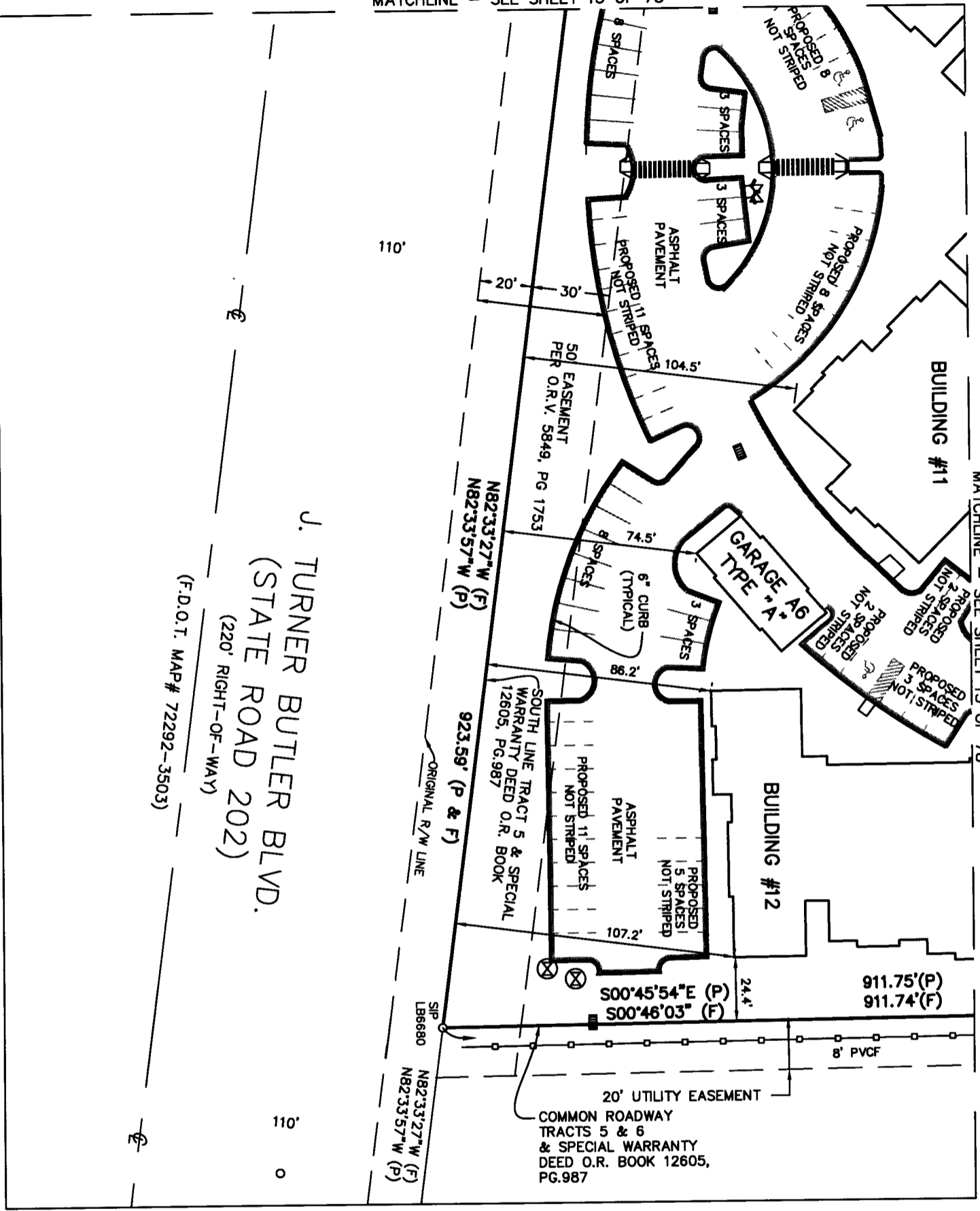

J. TURNER BUTLER BLVD.
(STATE ROAD 202)
(220' RIGHT-OF-WAY)

(F.D.O.T. MAP# 72292-3503)

MATCHLINE - SEE SHEET 13 OF 78

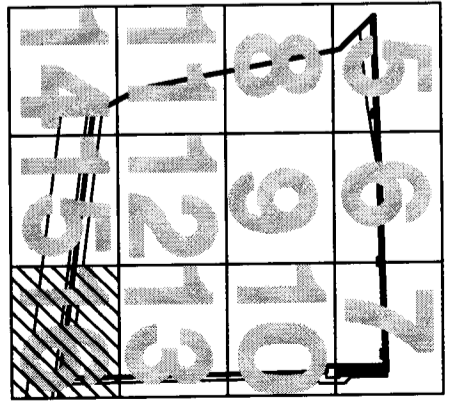
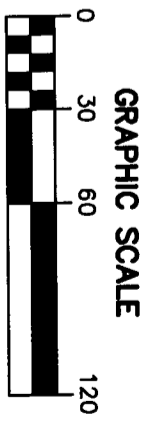

EXHIBIT A TO THE DECLARATION OF CONDOMINIUM
GARDENS OF BRIDGEHAMPTON,
A CONDOMINIUM



MILLER LEGG
South Florida Office: 1800 North Douglas Road - Suite 200
Pembroke Pines, Florida - 33024-3200
954-436-7000 · Fax: 954-436-8664
www.millerlegg.com

Certificate of Authorization L.B. 6680

SKETCH OF BOUNDARY SURVEY

PROJECT NO.
05-00436

FILE NO.
11-1C-280

EXHIBIT A TO THE DECLARATION OF CONDOMINIUM GARDENS OF BRIDGEHAMPTON, A CONDOMINIUM

BUILDING #1 FIRST FLOOR

BUILDING #1

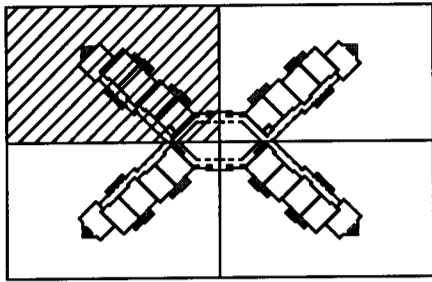

N.T.S.

MATCHLINE - SEE PAGE 19 OF 78

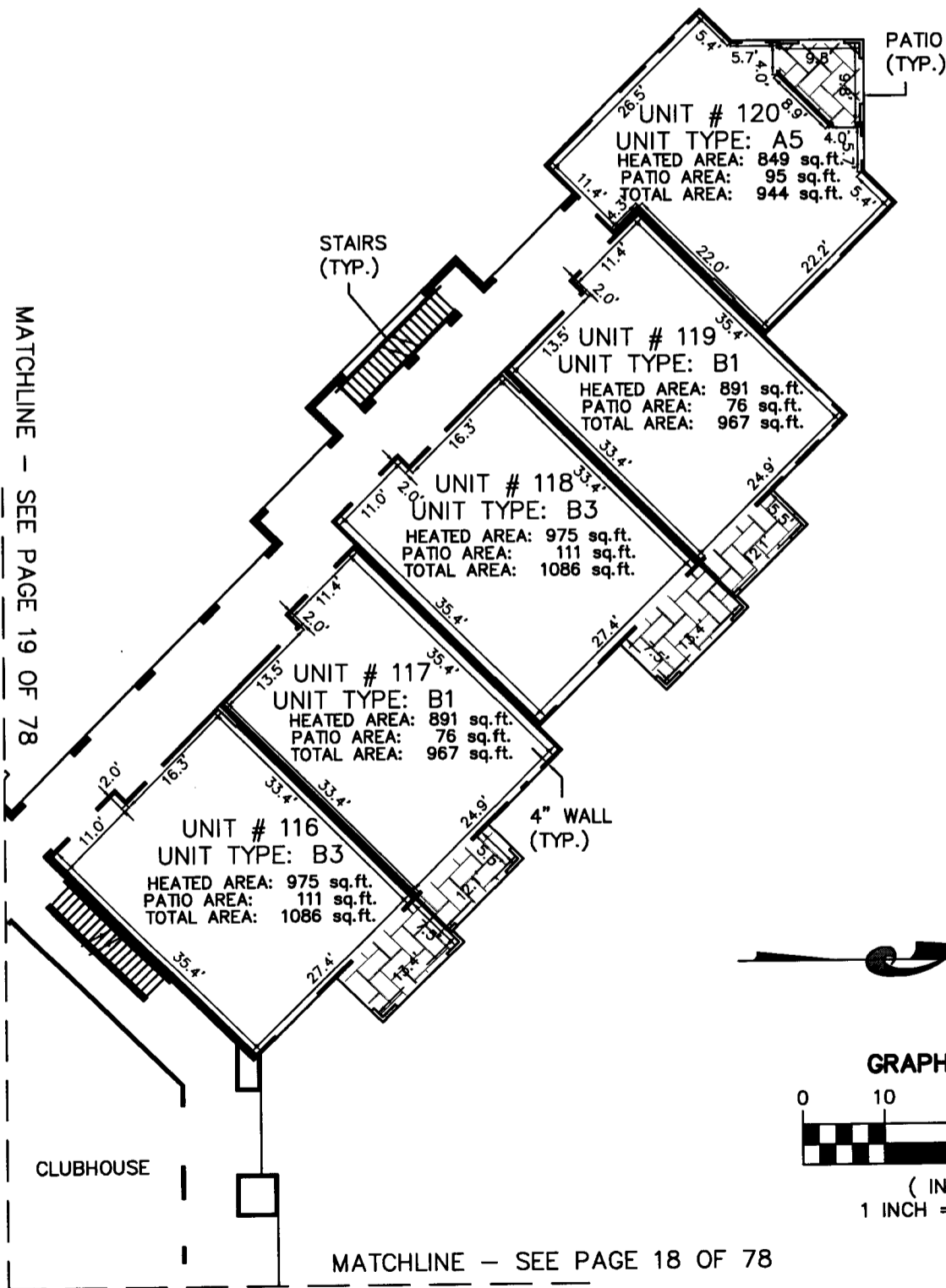

MATCHLINE - SEE PAGE 18 OF 78

CLUBHOUSE

MILLER LEGG

South Florida Office: 1800 North Douglas Road - Suite 200
Pembroke Pines, Florida - 33024-3200
954-436-7000 - Fax: 954-436-8884
www.millerlegg.com

Certificate of Authorization L.B. 6880

EXHIBIT

THIS SKETCH DOES NOT REPRESENT A BOUNDARY SURVEY

PROJECT NO.
05-00436

FILE NO.
11-1C-280



LIMITED COMMON ELEMENT

MATCHLINE - SEE PAGE 17 OF 78

CLUBHOUSE

BUILDING #1

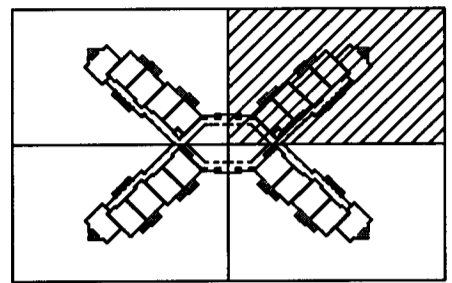

N.T.S.

UNIT # 101
UNIT TYPE: B3
HEATED AREA: 975 sq.ft.
PATIO AREA: 111 sq.ft.
TOTAL AREA: 1086 sq.ft.

UNIT # 102
UNIT TYPE: B1
HEATED AREA: 891 sq.ft.
PATIO AREA: 76 sq.ft.
TOTAL AREA: 967 sq.ft.

UNIT # 103
UNIT TYPE: B3
HEATED AREA: 975 sq.ft.
PATIO AREA: 111 sq.ft.
TOTAL AREA: 1086 sq.ft.

UNIT # 104
UNIT TYPE: B1
HEATED AREA: 891 sq.ft.
PATIO AREA: 76 sq.ft.
TOTAL AREA: 967 sq.ft.

UNIT # 105
UNIT TYPE: A5
HEATED AREA: 849 sq.ft.
PATIO AREA: 95 sq.ft.
TOTAL AREA: 944 sq.ft.

4" WALL (TYP.)

STAIRS (TYP.)

PATIO (TYP.)

MATCHLINE - SEE PAGE 20 OF 78

EXHIBIT A TO THE DECLARATION OF CONDOMINIUM
GARDENS OF BRIDGEHAMPTON,
A CONDOMINIUM

BUILDING #1
FIRST FLOOR



GRAPHIC SCALE

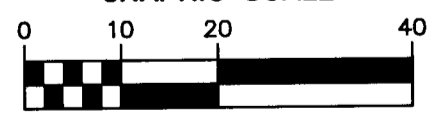

(IN FEET)
1 INCH = 20 FEET



LIMITED COMMON ELEMENT

MILLER LEGG

South Florida Office: 1800 North Douglas Road - Suite 200
Pembroke Pines, Florida - 33024-3200
954-436-7000 - Fax: 954-436-8864
www.millerlegg.com

Certificate of Authorization L.B. 6680

THIS SKETCH DOES NOT REPRESENT A BOUNDARY SURVEY

EXHIBIT

PROJECT NO.
05-00436

FILE NO.
11-1C-280

EXHIBIT A TO THE DECLARATION OF CONDOMINIUM GARDENS OF BRIDGEHAMPTON, A CONDOMINIUM

BUILDING #1

BUILDING #1

FIRST FLOOR

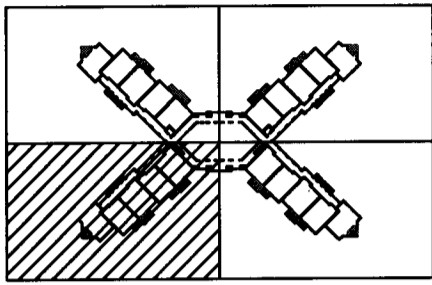

N.T.S.

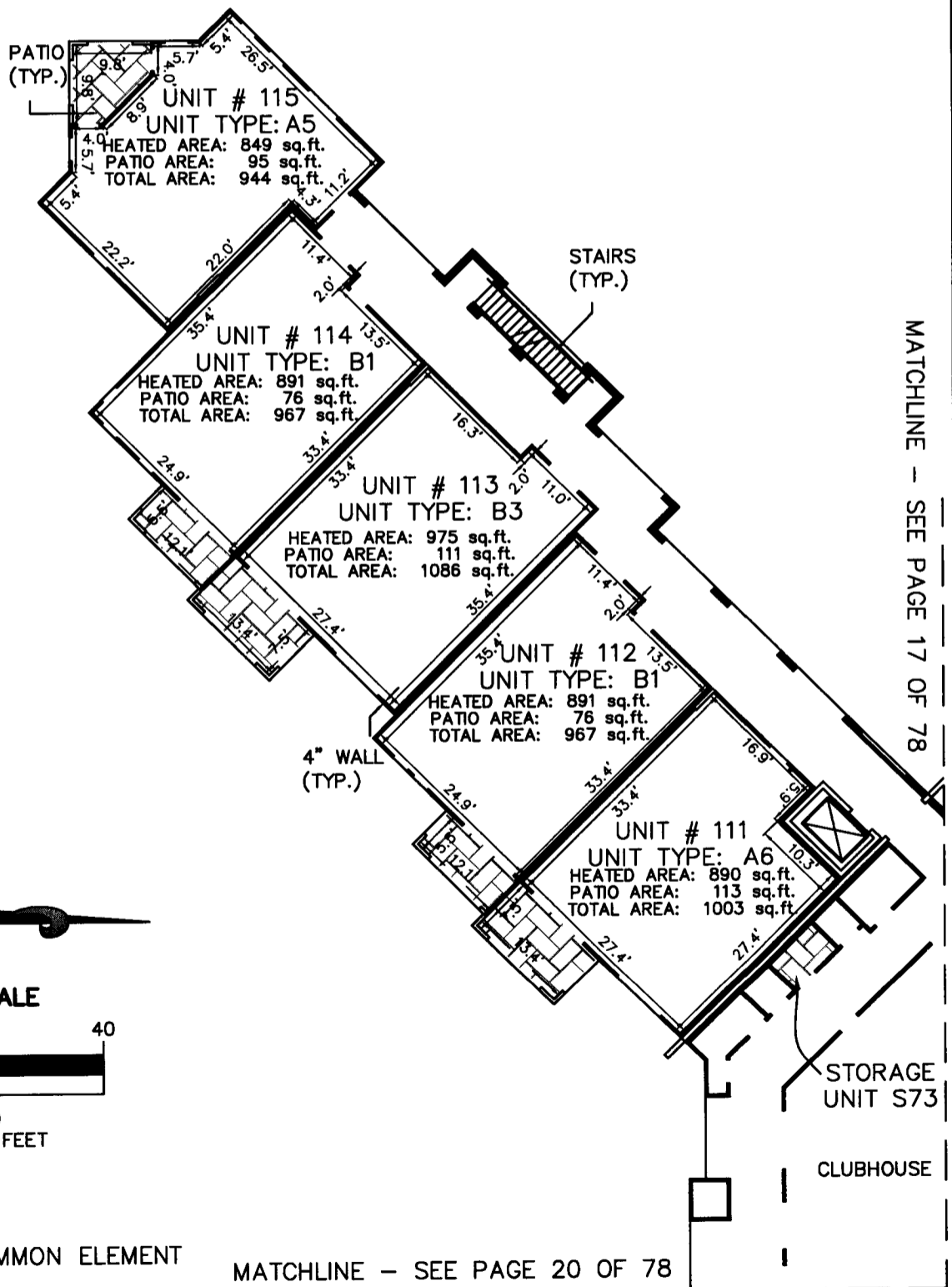

MILLER LEGG

South Florida Office: 1800 North Douglas Road - Suite 200
Pembroke Pines, Florida - 33024-3200
954-436-7000 - Fax: 954-436-8664
www.millerlegg.com

Certificate of Authorization L.B. 6680

THIS SKETCH DOES NOT REPRESENT A BOUNDARY SURVEY

EXHIBIT

PROJECT NO.
05-00436

FILE NO.
11-1C-280

MATCHLINE - SEE PAGE 19 OF 78

SHEET 20 OF 78

BUILDING #1

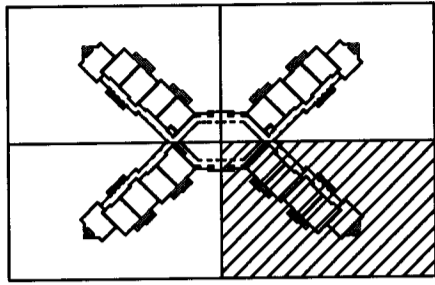

N.T.S.

CLUBHOUSE

STORAGE UNIT S74

UNIT # 106
 UNIT TYPE: A6
 HEATED AREA: 890 sq.ft.
 PATIO AREA: 113 sq.ft.
 TOTAL AREA: 1003 sq.ft.

UNIT # 107
 UNIT TYPE: B1
 HEATED AREA: 891 sq.ft.
 PATIO AREA: 76 sq.ft.
 TOTAL AREA: 967 sq.ft.

4" WALL (TYP.)

UNIT # 108
 UNIT TYPE: B3
 HEATED AREA: 975 sq.ft.
 PATIO AREA: 111 sq.ft.
 TOTAL AREA: 1086 sq.ft.

UNIT # 109
 UNIT TYPE: B1
 HEATED AREA: 891 sq.ft.
 PATIO AREA: 76 sq.ft.
 TOTAL AREA: 967 sq.ft.

STAIRS (TYP.)

UNIT # 110
 UNIT TYPE: A5
 HEATED AREA: 849 sq.ft.
 PATIO AREA: 95 sq.ft.
 TOTAL AREA: 944 sq.ft.

PATIO (TYP.)

MATCHLINE - SEE PAGE 18 OF 78

EXHIBIT A TO THE DECLARATION OF CONDOMINIUM
GARDENS OF BRIDGEHAMPTON,
A CONDOMINIUM

BUILDING #1

FIRST FLOOR



GRAPHIC SCALE



(IN FEET)
1 INCH = 20 FEET



LIMITED COMMON ELEMENT

MILLER LEGG

South Florida Office: 1800 North Douglas Road · Suite 200
 Pembroke Pines, Florida · 33024-3200
 954-436-7000 · Fax: 954-436-8664
 www.millerlegg.com

Certificate of Authorization L.B. 6680

THIS SKETCH DOES NOT REPRESENT A BOUNDARY SURVEY

EXHIBIT

PROJECT NO.
05-00436

FILE NO.
11-1C-280

EXHIBIT A TO THE DECLARATION OF CONDOMINIUM GARDENS OF BRIDGEHAMPTON, A CONDOMINIUM

BUILDING #1 SECOND FLOOR

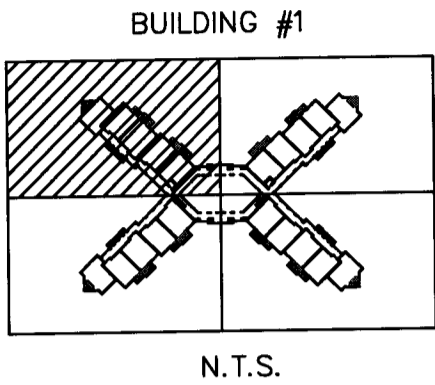

MATCHLINE - SEE PAGE 23 OF 78

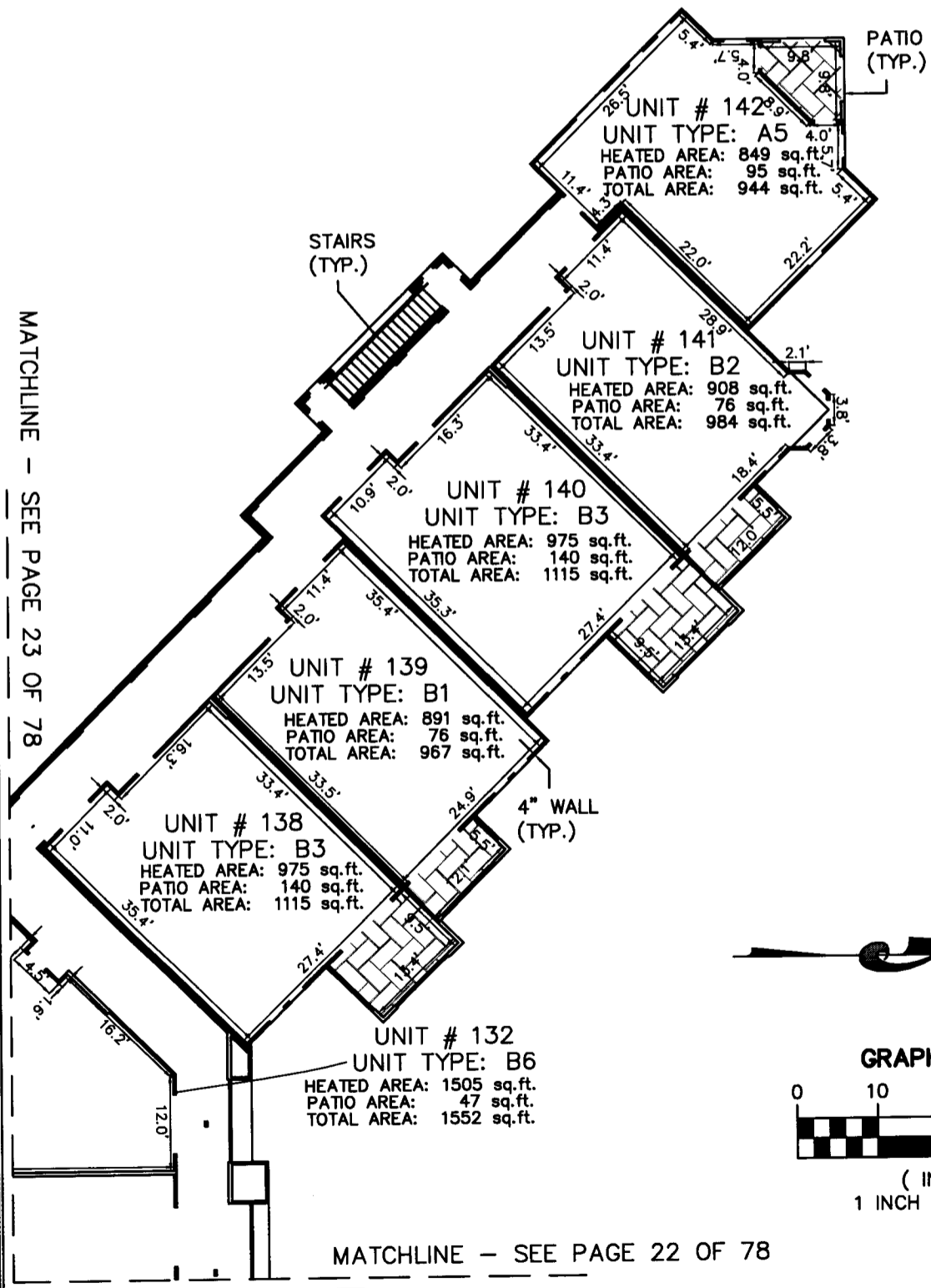

MATCHLINE - SEE PAGE 22 OF 78

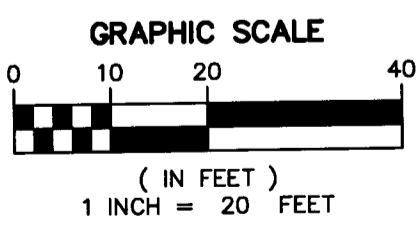

LIMITED COMMON ELEMENT

THIS SKETCH DOES NOT REPRESENT A BOUNDARY SURVEY

MILLER LEGG
South Florida Office: 1800 North Douglas Road - Suite 200
Pembroke Pines, Florida - 33024-3200
954-436-7000 · Fax: 954-436-8664
www.millerlegg.com

Certificate of Authorization L.B. 6680

EXHIBIT

PROJECT NO.
05-00436

FILE NO.
11-1C-280

MATCHLINE - SEE PAGE 21 OF 78

UNIT # 126
UNIT TYPE: B6
HEATED AREA: 1505 sq.ft.
PATIO AREA: 47 sq.ft.
TOTAL AREA: 1552 sq.ft.

UNIT # 121
UNIT TYPE: B3
HEATED AREA: 975 sq.ft.
PATIO AREA: 140 sq.ft.
TOTAL AREA: 1115 sq.ft.

UNIT # 122
UNIT TYPE: B1
HEATED AREA: 891 sq.ft.
PATIO AREA: 76 sq.ft.
TOTAL AREA: 967 sq.ft.

UNIT # 123
UNIT TYPE: B3
HEATED AREA: 975 sq.ft.
PATIO AREA: 140 sq.ft.
TOTAL AREA: 1115 sq.ft.

UNIT # 124
UNIT TYPE: B2
HEATED AREA: 908 sq.ft.
PATIO AREA: 76 sq.ft.
TOTAL AREA: 984 sq.ft.

UNIT # 125
UNIT TYPE: A5
HEATED AREA: 849 sq.ft.
PATIO AREA: 95 sq.ft.
TOTAL AREA: 944 sq.ft.

BUILDING #1

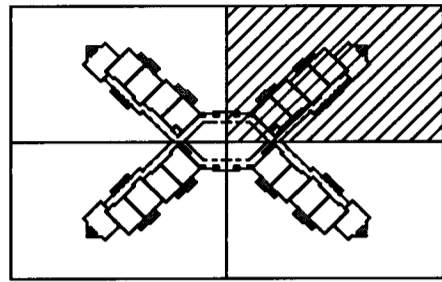

N.T.S.

4" WALL (TYP.)

STAIRS (TYP.)

PATIO (TYP.)

MATCHLINE - SEE PAGE 24 OF 78

EXHIBIT A TO THE DECLARATION OF CONDOMINIUM
GARDENS OF BRIDGEHAMPTON,
A CONDOMINIUM

BUILDING #1
SECOND FLOOR



GRAPHIC SCALE



(IN FEET)
1 INCH = 20 FEET



LIMITED COMMON ELEMENT

MILLER LEGG

South Florida Office: 1800 North Douglas Road - Suite 200
Pembroke Pines, Florida - 33024-3200
954-436-7000 - Fax: 954-436-8664
www.millerlegg.com

Certificate of Authorization L.B. 6680

THIS SKETCH DOES NOT REPRESENT A BOUNDARY SURVEY

EXHIBIT

PROJECT NO.
05-00436

FILE NO.
11-1C-280

EXHIBIT A TO THE DECLARATION OF CONDOMINIUM GARDENS OF BRIDGEHAMPTON, A CONDOMINIUM

BUILDING #1 SECOND FLOOR

BUILDING #1

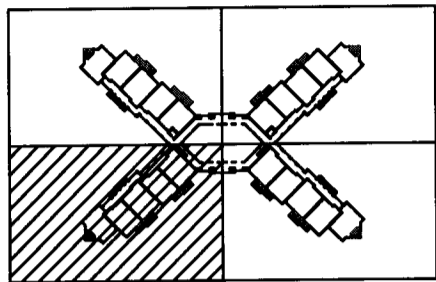

N.T.S.

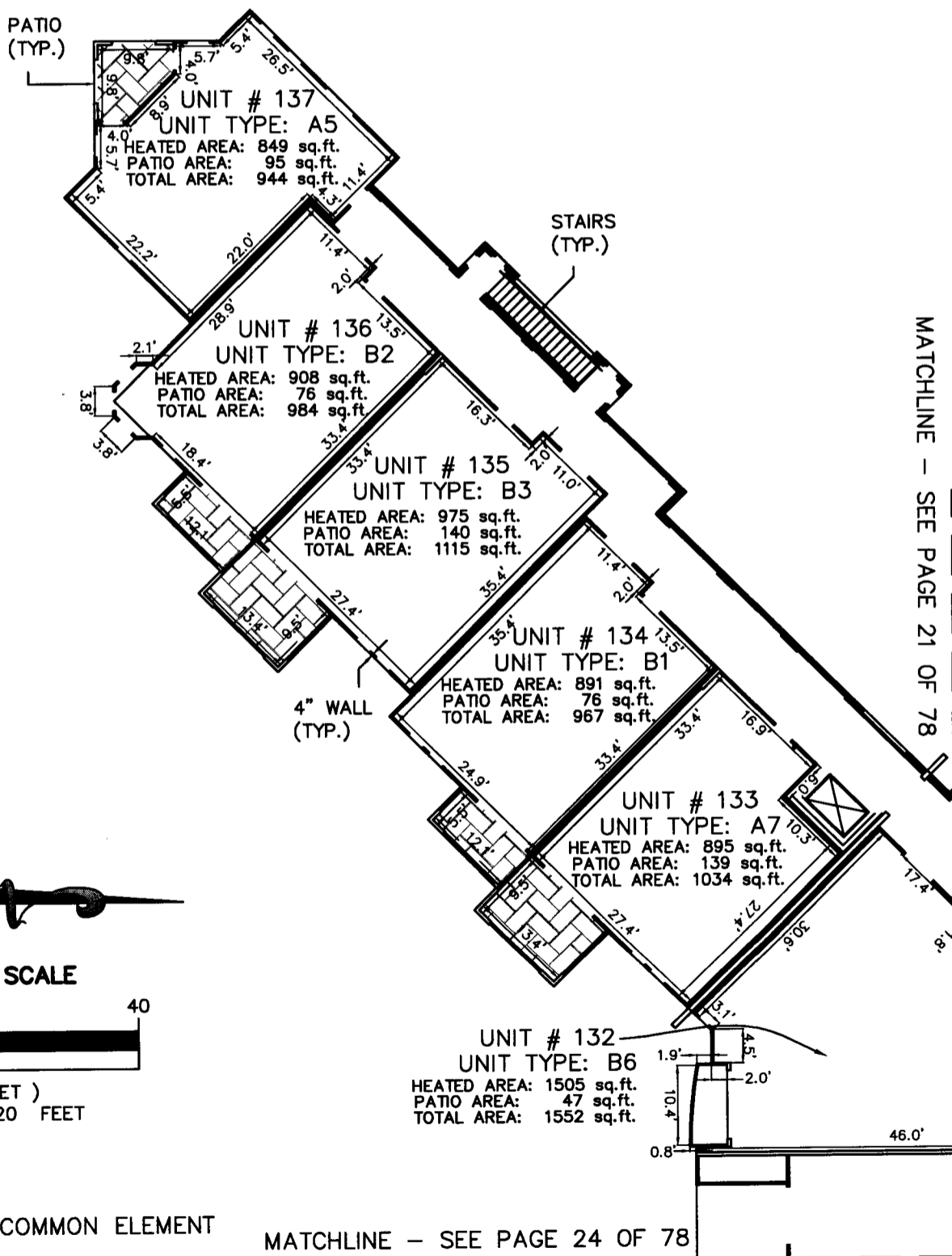

MILLER LEGG

South Florida Office: 1800 North Douglas Road · Suite 200
Pembroke Pines, Florida · 33024-3200
954-436-7000 · Fax: 954-436-8684
www.millerlegg.com

Certificate of Authorization L.B. 6680

THIS SKETCH DOES NOT REPRESENT A BOUNDARY SURVEY

EXHIBIT

PROJECT NO.
05-00436

FILE NO.
11-1C-280

EXHIBIT A TO THE DECLARATION OF CONDOMINIUM GARDENS OF BRIDGEHAMPTON, A CONDOMINIUM

BUILDING #1 THIRD FLOOR

BUILDING #1

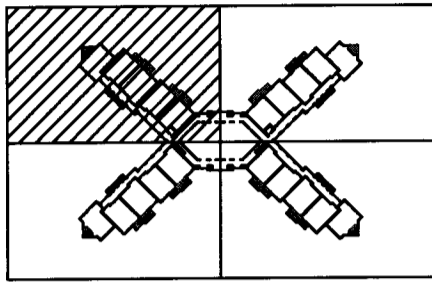

N.T.S.

MATCHLINE - SEE PAGE 27 OF 78

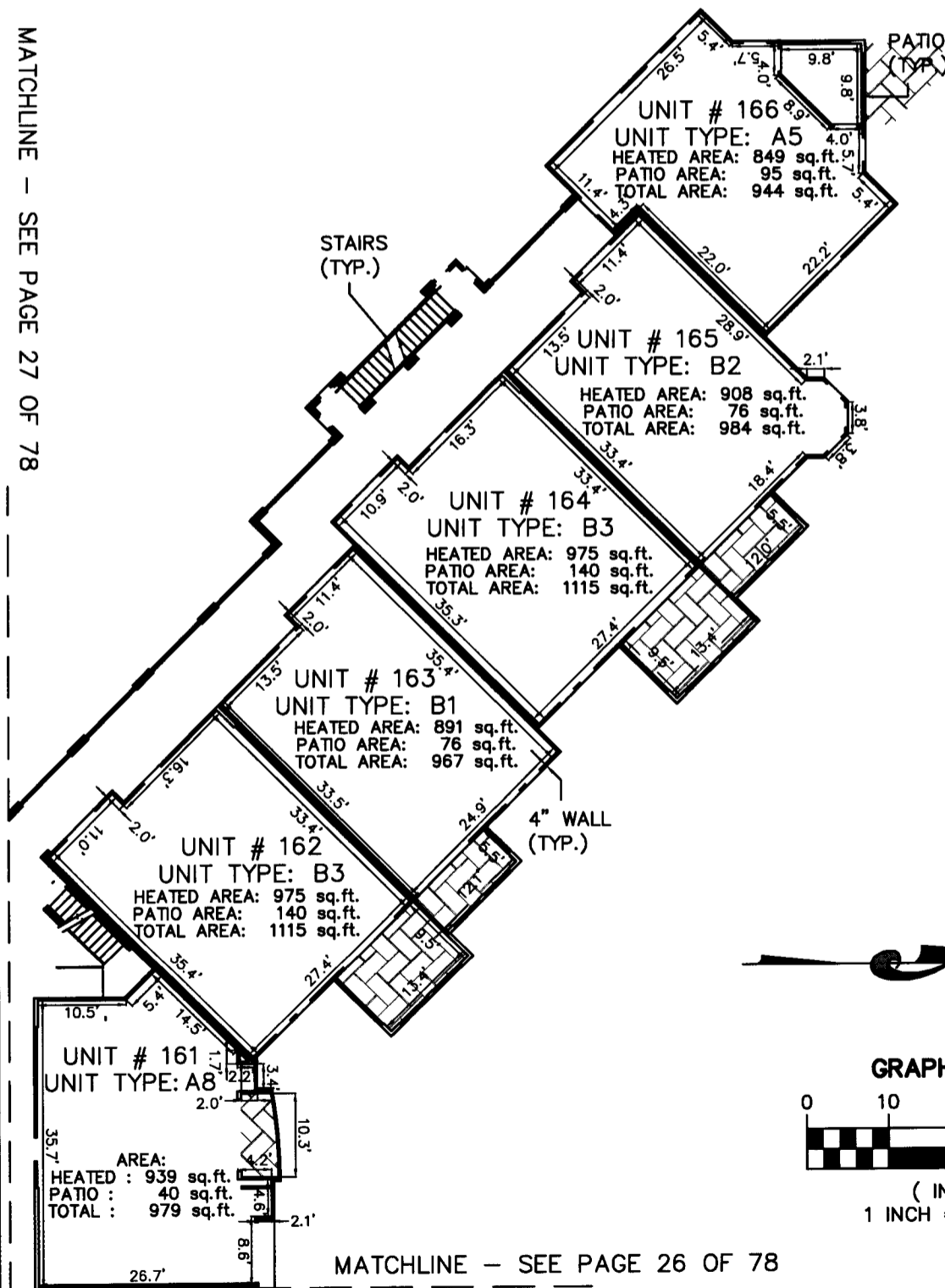

MATCHLINE - SEE PAGE 26 OF 78



GRAPHIC SCALE



(IN FEET)
1 INCH = 20 FEET



LIMITED COMMON ELEMENT

MILLER LEGG

South Florida Office: 1800 North Douglas Road - Suite 200
Pembroke Pines, Florida - 33024-3200
954-436-7000 - Fax: 954-436-8664
www.millerlegg.com

Certificate of Authorization L.B. 6680

THIS SKETCH DOES NOT REPRESENT A BOUNDARY SURVEY

EXHIBIT

PROJECT NO.
05-00436

FILE NO.
11-1C-280

MATCHLINE - SEE PAGE 25 OF 78

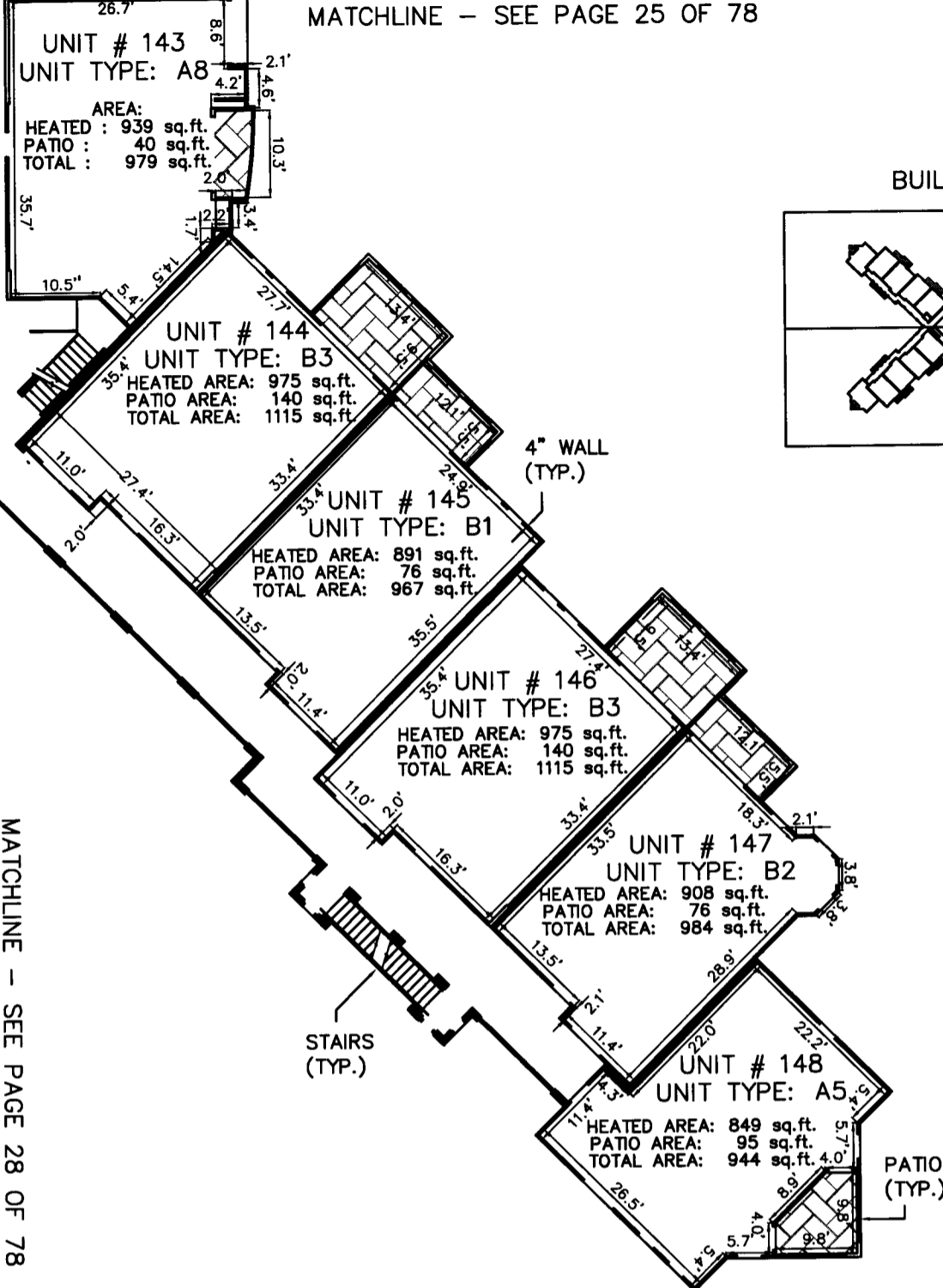

BUILDING #1

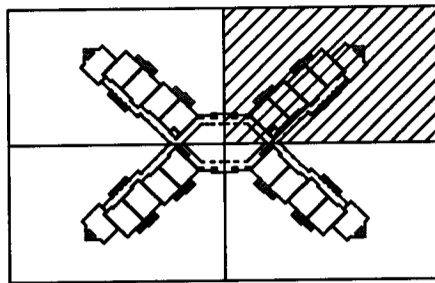

N.T.S.

MATCHLINE - SEE PAGE 28 OF 78

EXHIBIT A TO THE DECLARATION OF CONDOMINIUM
GARDENS OF BRIDGEHAMPTON,
 A CONDOMINIUM

BUILDING #1

THIRD FLOOR



GRAPHIC SCALE



(IN FEET)
1 INCH = 20 FEET



LIMITED COMMON ELEMENT

MILLER LEGG

South Florida Office: 1800 North Douglas Road · Suite 200
Pembroke Pines, Florida · 33024-3200
954-436-7000 · Fax: 954-436-8864
www.millerlegg.com

Certificate of Authorization L.B. 6680

THIS SKETCH DOES NOT REPRESENT A BOUNDARY SURVEY

EXHIBIT

PROJECT NO.
05-00436

FILE NO.
11-1C-280

EXHIBIT A TO THE DECLARATION OF CONDOMINIUM GARDENS OF BRIDGEHAMPTON, A CONDOMINIUM

BUILDING #1

BUILDING #1

THIRD FLOOR

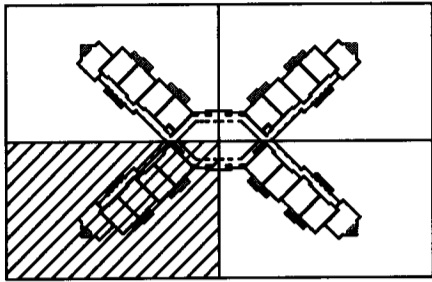

N.T.S.

MATCHLINE - SEE PAGE 25 OF 78

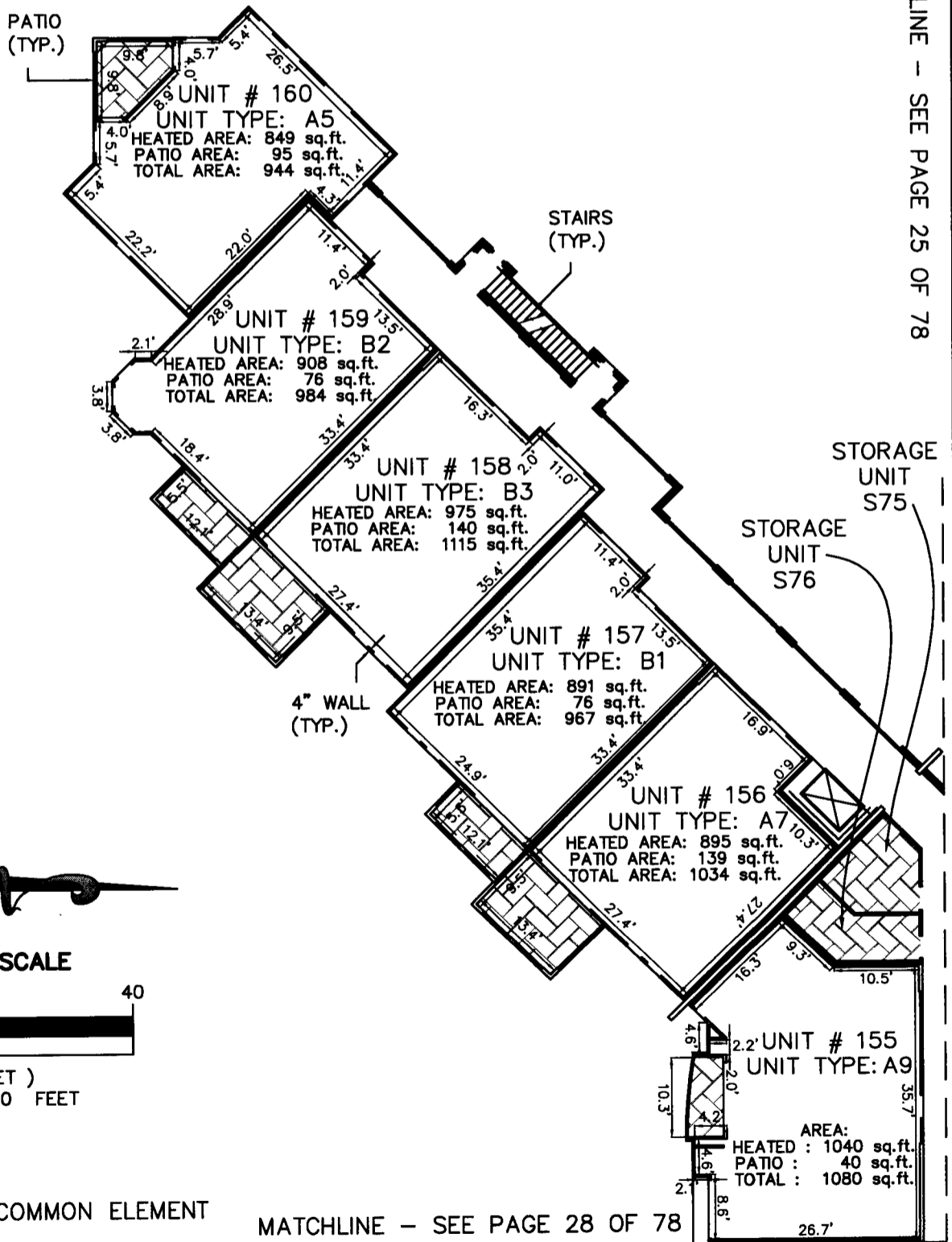

MATCHLINE - SEE PAGE 28 OF 78



GRAPHIC SCALE



(IN FEET)
1 INCH = 20 FEET



LIMITED COMMON ELEMENT

MILLER LEGG

South Florida Office: 1800 North Douglas Road - Suite 200
Pembroke Pines, Florida - 33024-3200
954-436-7000 - Fax: 954-436-8684
www.millerlegg.com

Certificate of Authorization L.B. 6680

THIS SKETCH DOES NOT REPRESENT A BOUNDARY SURVEY

EXHIBIT

PROJECT NO.
05-00436

FILE NO.
11-1C-280

MATCHLINE - SEE PAGE 27 OF 78

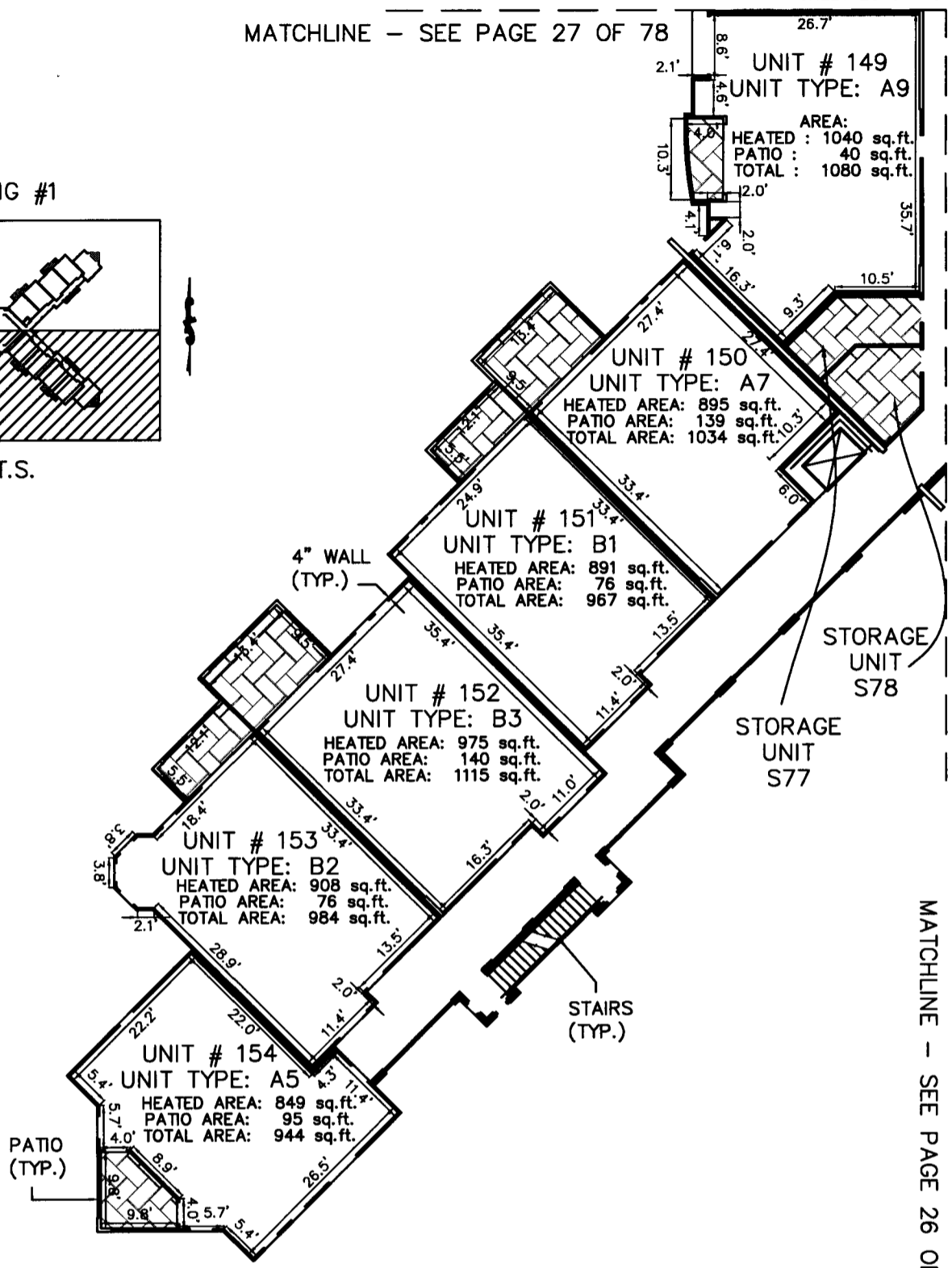
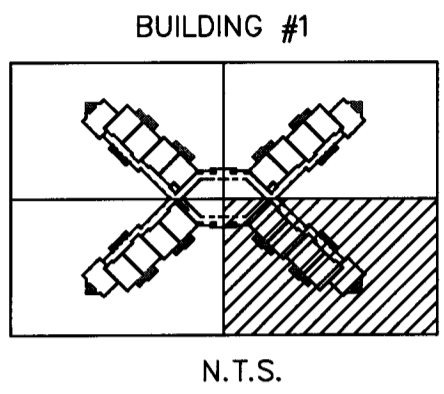

MATCHLINE - SEE PAGE 26 OF 78

EXHIBIT A TO THE DECLARATION OF CONDOMINIUM
GARDENS OF BRIDGEHAMPTON,
A CONDOMINIUM

BUILDING #1
THIRD FLOOR

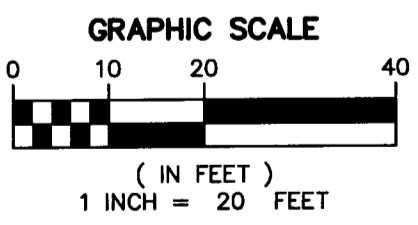

LIMITED COMMON ELEMENT

MILLER LEGG

South Florida Office: 1800 North Douglas Road · Suite 200
Pembroke Pines, Florida · 33024-3200
954-436-7000 · Fax: 954-436-8864
www.millerlegg.com

Certificate of Authorization L.B. 6680

THIS SKETCH DOES NOT REPRESENT A BOUNDARY SURVEY

EXHIBIT

PROJECT NO.
05-00436

FILE NO.
11-1C-280

EXHIBIT A TO THE DECLARATION OF CONDOMINIUM GARDENS OF BRIDGEHAMPTON, A CONDOMINIUM

BUILDING #1

BUILDING #1

FOURTH FLOOR

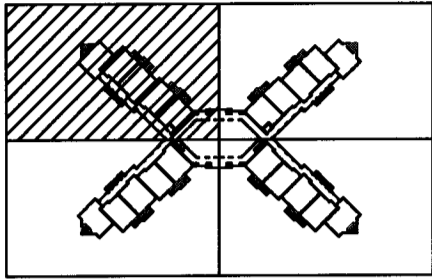

N.T.S.

MATCHLINE - SEE PAGE 31 OF 78

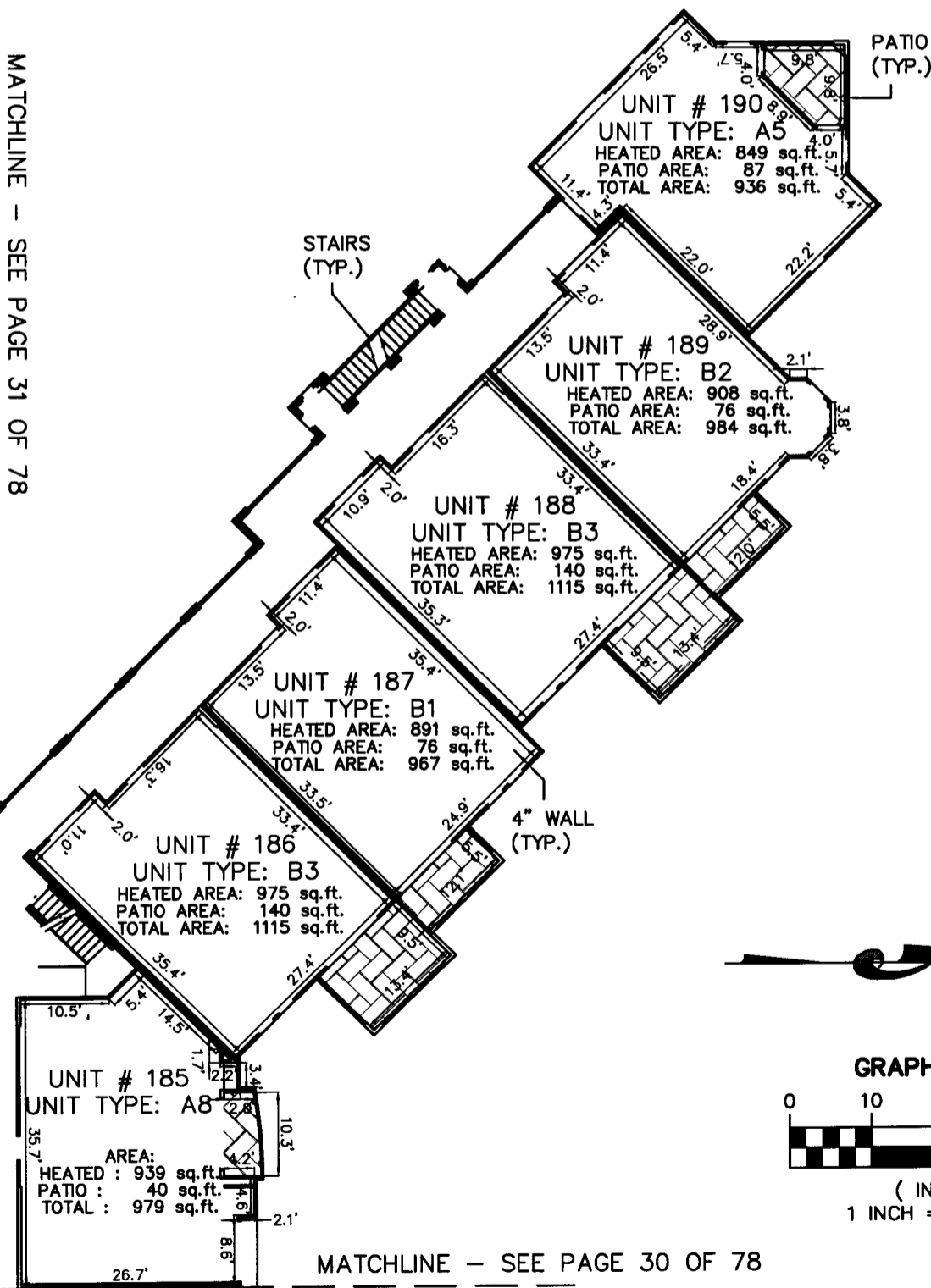

MATCHLINE - SEE PAGE 30 OF 78



GRAPHIC SCALE



(IN FEET)
1 INCH = 20 FEET



LIMITED COMMON ELEMENT

MILLER LEGG

South Florida Office: 1800 North Douglas Road - Suite 200
Pembroke Pines, Florida - 33024-3200
954-436-7000 - Fax: 954-436-8684
www.millerlegg.com

Certificate of Authorization L.B. 6680

THIS SKETCH DOES NOT REPRESENT A BOUNDARY SURVEY

EXHIBIT

PROJECT NO.
05-00436

FILE NO.
11-1C-280

MATCHLINE - SEE PAGE 29 OF 78

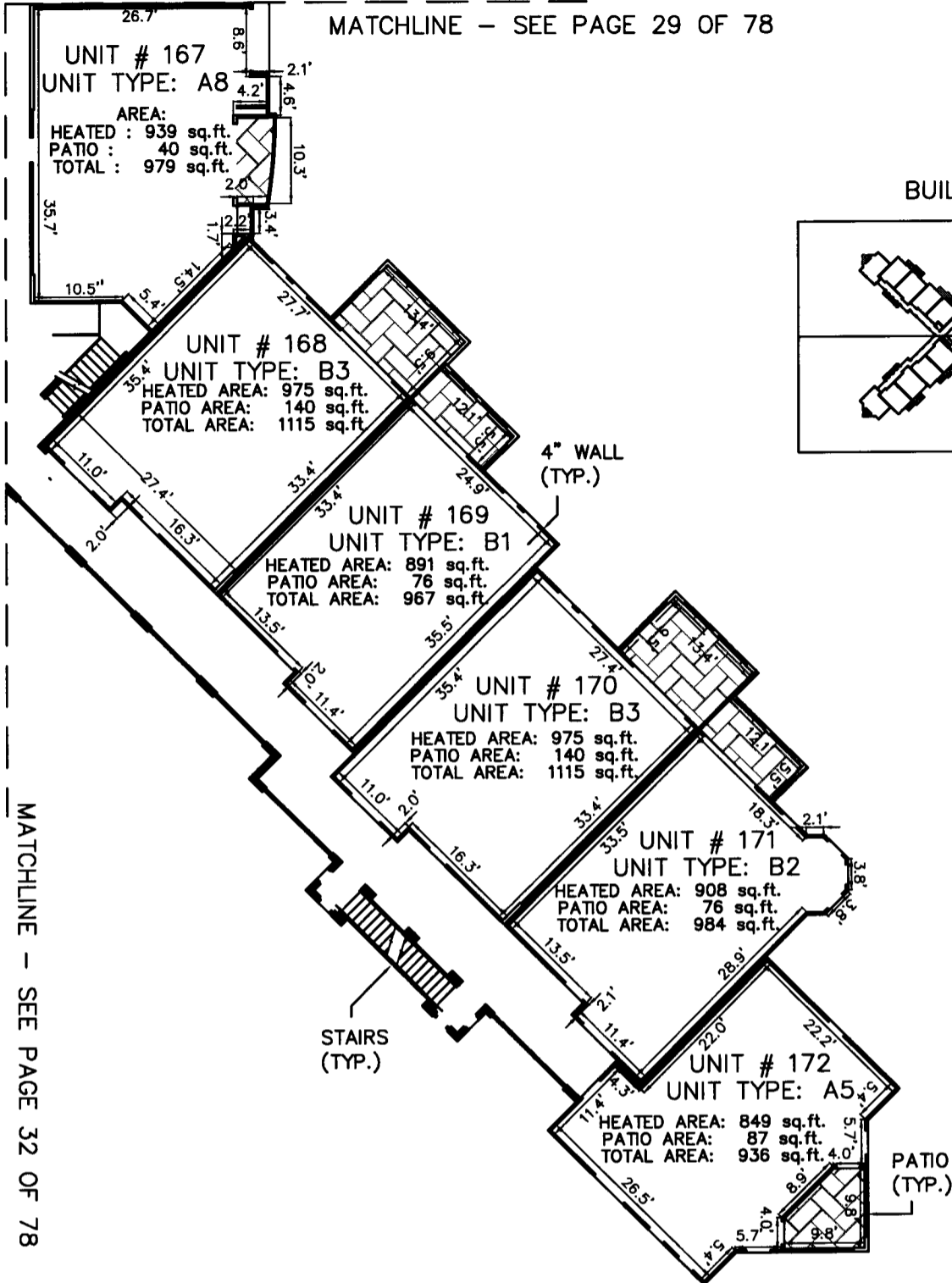

BUILDING #1

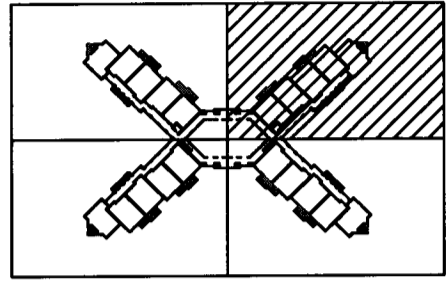

N.T.S.

MATCHLINE - SEE PAGE 32 OF 78

EXHIBIT A TO THE DECLARATION OF CONDOMINIUM
GARDENS OF BRIDGEHAMPTON,
A CONDOMINIUM

BUILDING #1
 FOURTH FLOOR



GRAPHIC SCALE



(IN FEET)
 1 INCH = 20 FEET



LIMITED COMMON ELEMENT

MILLER LEGG

South Florida Office: 1800 North Douglas Road - Suite 200
 Pembroke Pines, Florida - 33024-3200
 954-436-7000 - Fax: 954-436-8664
 www.millerlegg.com

Certificate of Authorization L.B. 6680

THIS SKETCH DOES NOT REPRESENT A BOUNDARY SURVEY

EXHIBIT

PROJECT NO.
05-00436

FILE NO.
11-1C-280

EXHIBIT A TO THE DECLARATION OF CONDOMINIUM GARDENS OF BRIDGEHAMPTON, A CONDOMINIUM

BUILDING #1

FOURTH FLOOR

BUILDING #1

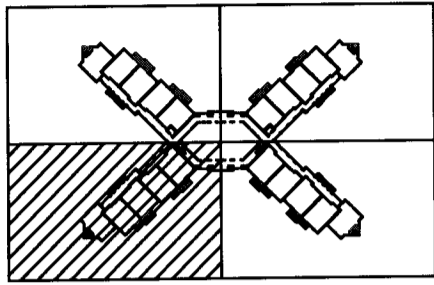

N.T.S.

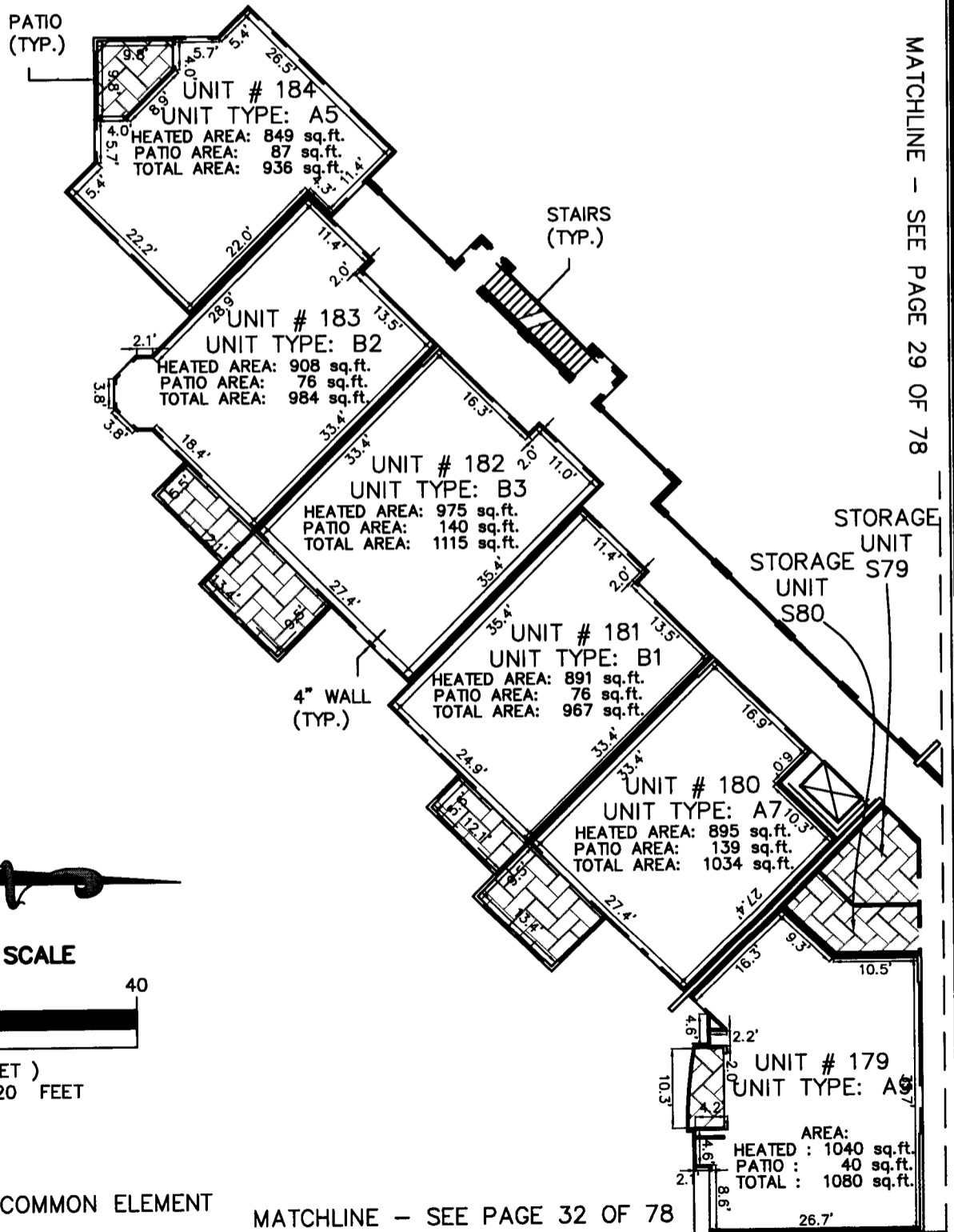

MATCHLINE - SEE PAGE 29 OF 78

STORAGE UNIT S79
STORAGE UNIT S80



GRAPHIC SCALE



(IN FEET)
1 INCH = 20 FEET



LIMITED COMMON ELEMENT

MATCHLINE - SEE PAGE 32 OF 78

MILLER LEGG

South Florida Office: 1800 North Douglas Road - Suite 200
Pembroke Pines, Florida - 33024-3200
954-436-7000 · Fax: 954-436-8664
www.millerlegg.com

Certificate of Authorization L.B. 6680

THIS SKETCH DOES NOT REPRESENT A BOUNDARY SURVEY

EXHIBIT

PROJECT NO.

05-00436

FILE NO.

11-1C-280

MATCHLINE - SEE PAGE 31 OF 78

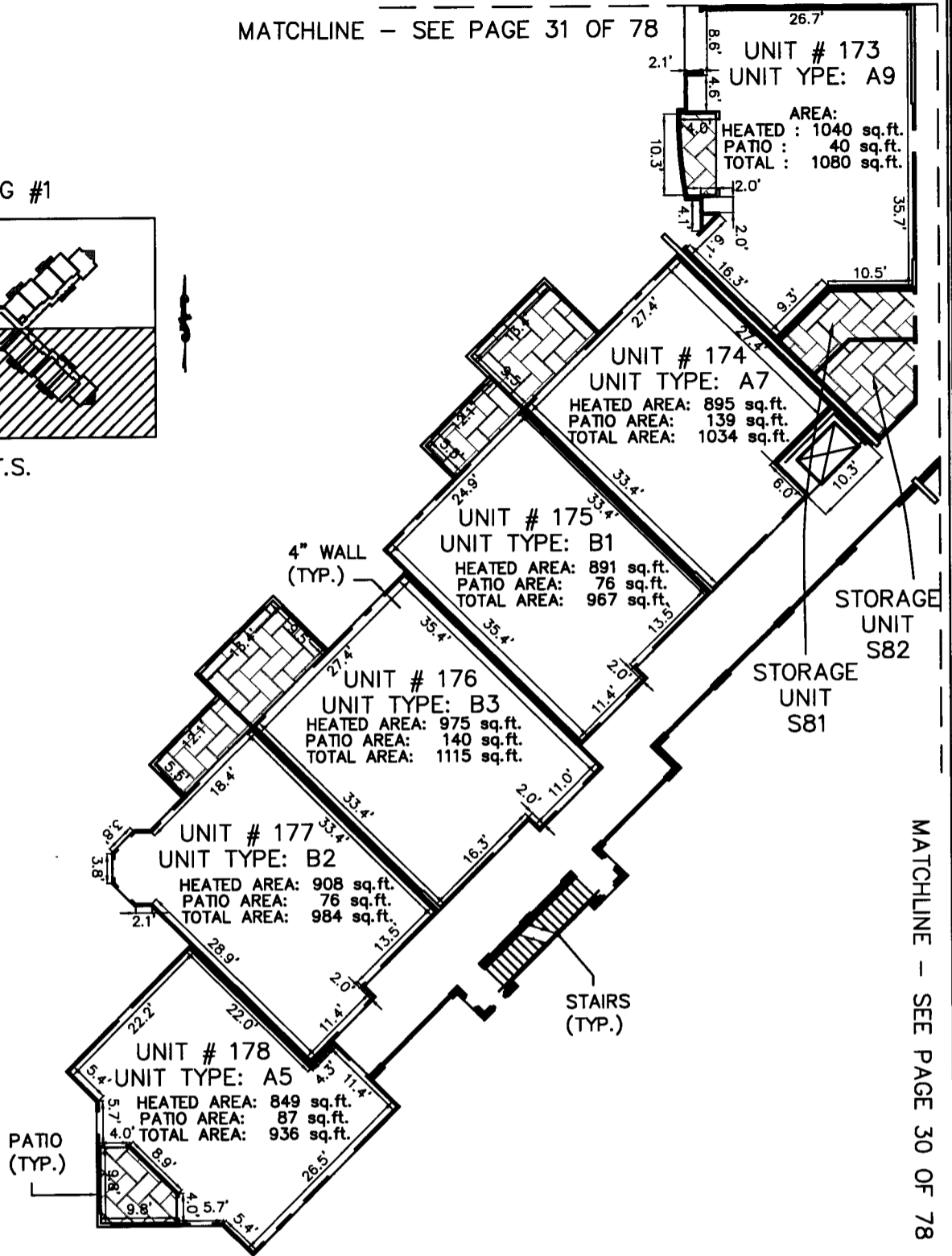
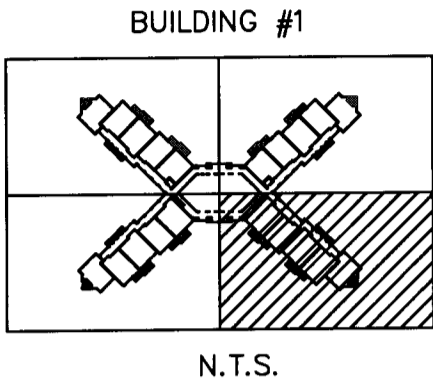

MATCHLINE - SEE PAGE 30 OF 78

EXHIBIT A TO THE DECLARATION OF CONDOMINIUM
GARDENS OF BRIDGEHAMPTON,
A CONDOMINIUM

BUILDING #1
 FOURTH FLOOR

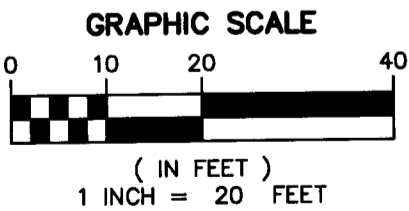

LIMITED COMMON ELEMENT

MILLER LEGG

South Florida Office: 1800 North Douglas Road - Suite 200
 Pembroke Pines, Florida - 33024-3200
 954-436-7000 · Fax: 954-436-8684
 www.millerlegg.com

Certificate of Authorization L.B. 6680

THIS SKETCH DOES NOT REPRESENT A BOUNDARY SURVEY

EXHIBIT

PROJECT NO.
05-00436

FILE NO.
11-1C-280

EXHIBIT A TO THE DECLARATION OF CONDOMINIUM GARDENS OF BRIDGEHAMPTON, A CONDOMINIUM

BUILDING #2 FIRST FLOOR

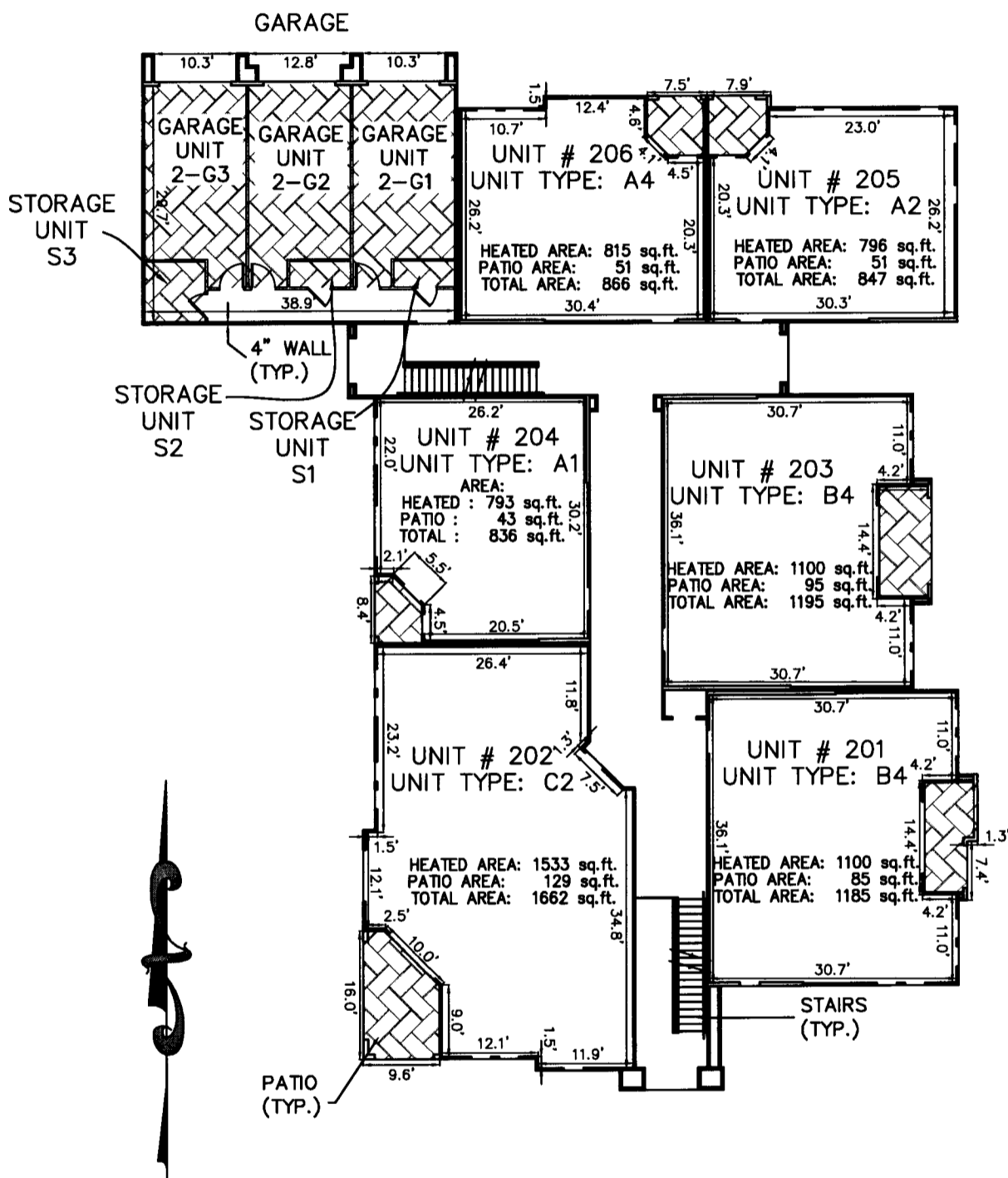

GRAPHIC SCALE



(IN FEET)
1 INCH = 20 FEET



LIMITED COMMON ELEMENT

MILLER LEGG

South Florida Office: 1800 North Douglas Road - Suite 200
Pembroke Pines, Florida - 33024-3200
954-436-7000 - Fax: 954-436-8684
www.millerlegg.com

Certificate of Authorization L.B. 6680

THIS SKETCH DOES NOT REPRESENT A BOUNDARY SURVEY

EXHIBIT

PROJECT NO.
05-00436

FILE NO.
11-1C-280

EXHIBIT A TO THE DECLARATION OF CONDOMINIUM GARDENS OF BRIDGEHAMPTON, A CONDOMINIUM

BUILDING #2 SECOND FLOOR

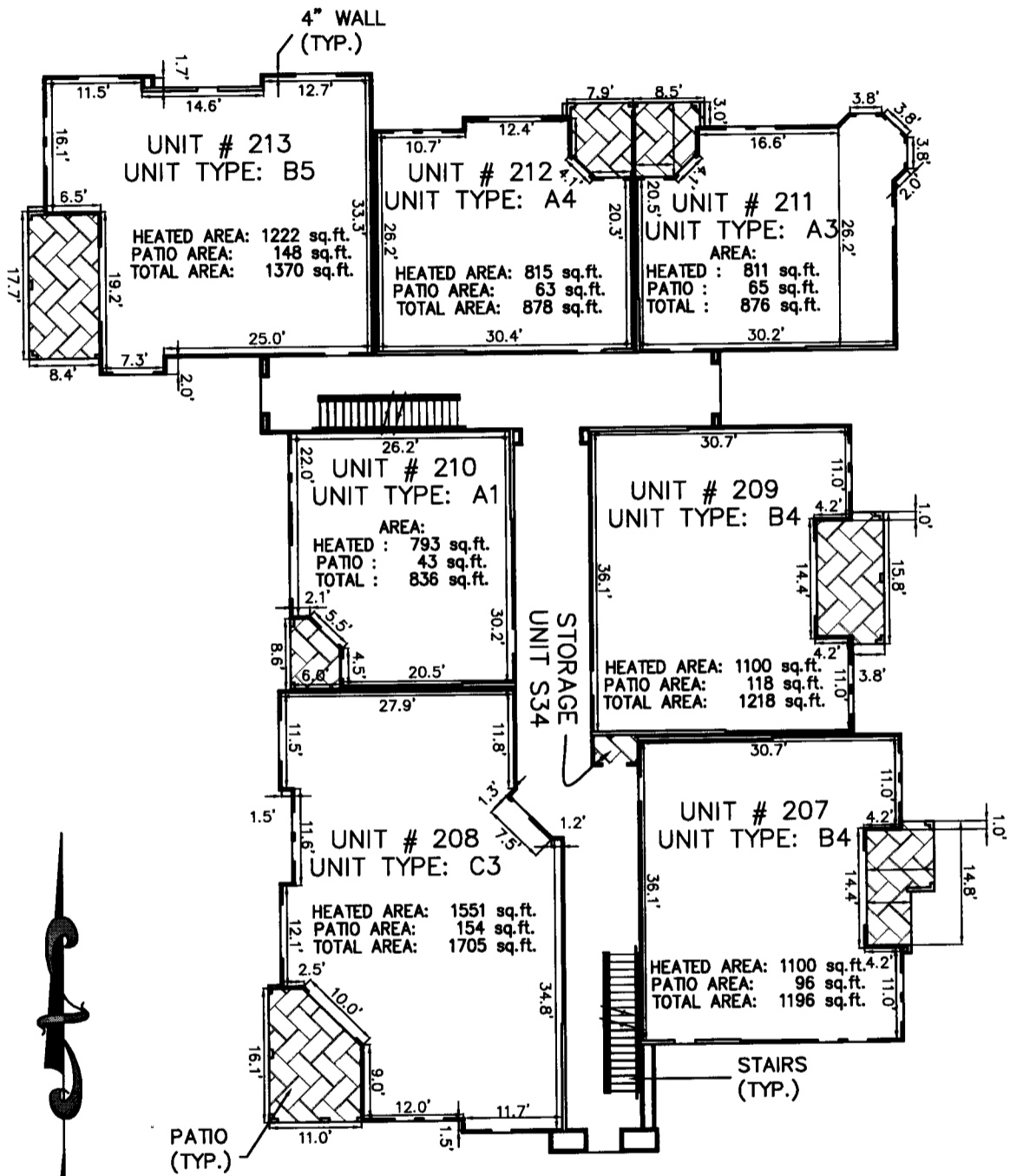

GRAPHIC SCALE



(IN FEET)
1 INCH = 20 FEET



LIMITED COMMON ELEMENT

MILLER LEGG

South Florida Office: 1800 North Douglas Road · Suite 200
Pembroke Pines, Florida · 33024-3200
954-436-7000 · Fax: 954-436-8884
www.millerlegg.com

Certificate of Authorization L.B. 6680

THIS SKETCH DOES NOT REPRESENT A BOUNDARY SURVEY

EXHIBIT

PROJECT NO.
05-00436

FILE NO.
11-1C-280

EXHIBIT A TO THE DECLARATION OF CONDOMINIUM GARDENS OF BRIDGEHAMPTON, A CONDOMINIUM

BUILDING #2

THIRD FLOOR

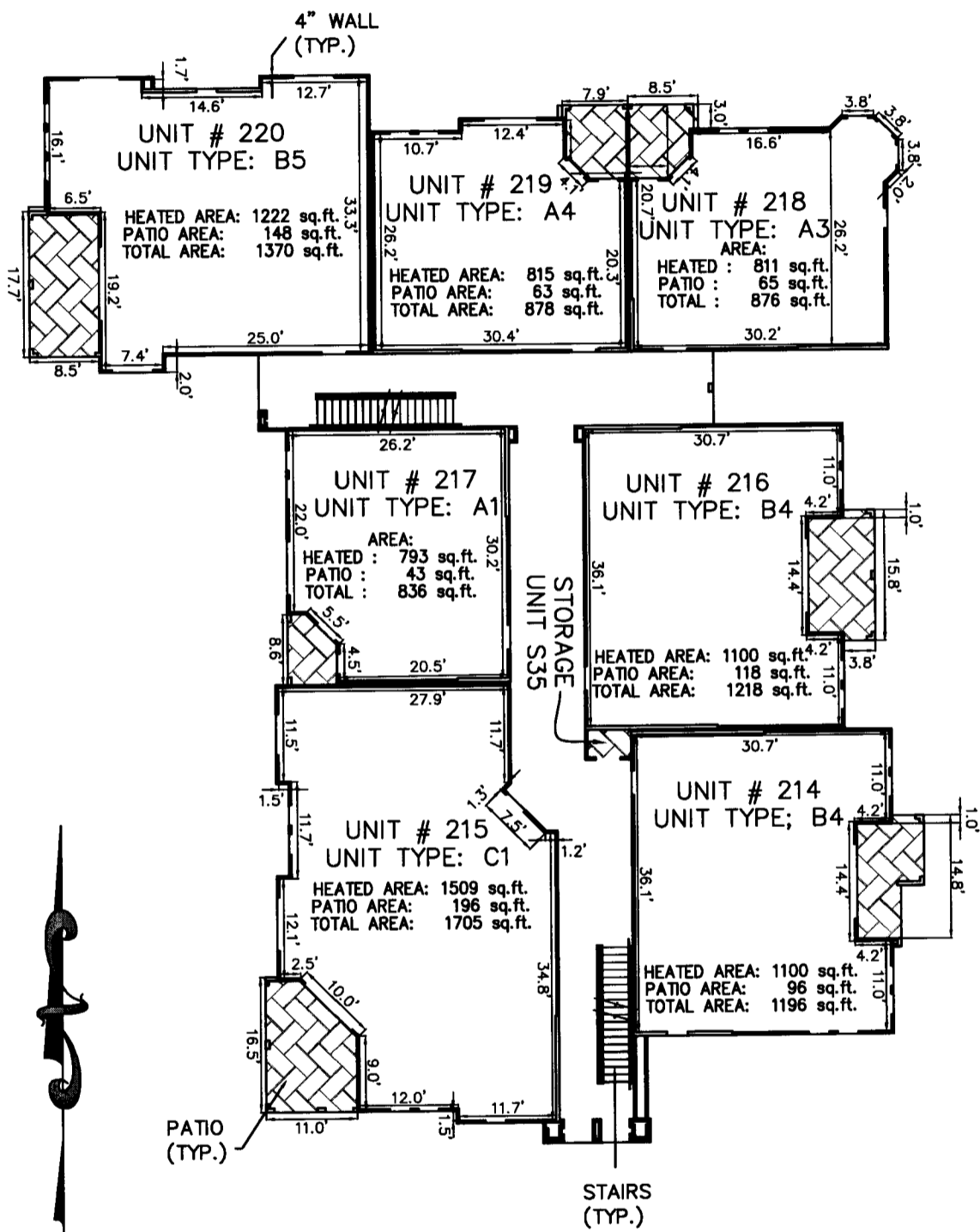

GRAPHIC SCALE



(IN FEET)
1 INCH = 20 FEET



LIMITED COMMON ELEMENT

MILLER LEGG

South Florida Office: 1800 North Douglas Road · Suite 200
Pembroke Pines, Florida · 33024-3200
954-436-7000 · Fax: 954-436-9664
www.millerlegg.com

Certificate of Authorization L.B. 6680

THIS SKETCH DOES NOT REPRESENT A BOUNDARY SURVEY

EXHIBIT

PROJECT NO.

05-00436

FILE NO.

11-1C-280

EXHIBIT A TO THE DECLARATION OF CONDOMINIUM GARDENS OF BRIDGEHAMPTON, A CONDOMINIUM

BUILDING #3 FIRST FLOOR

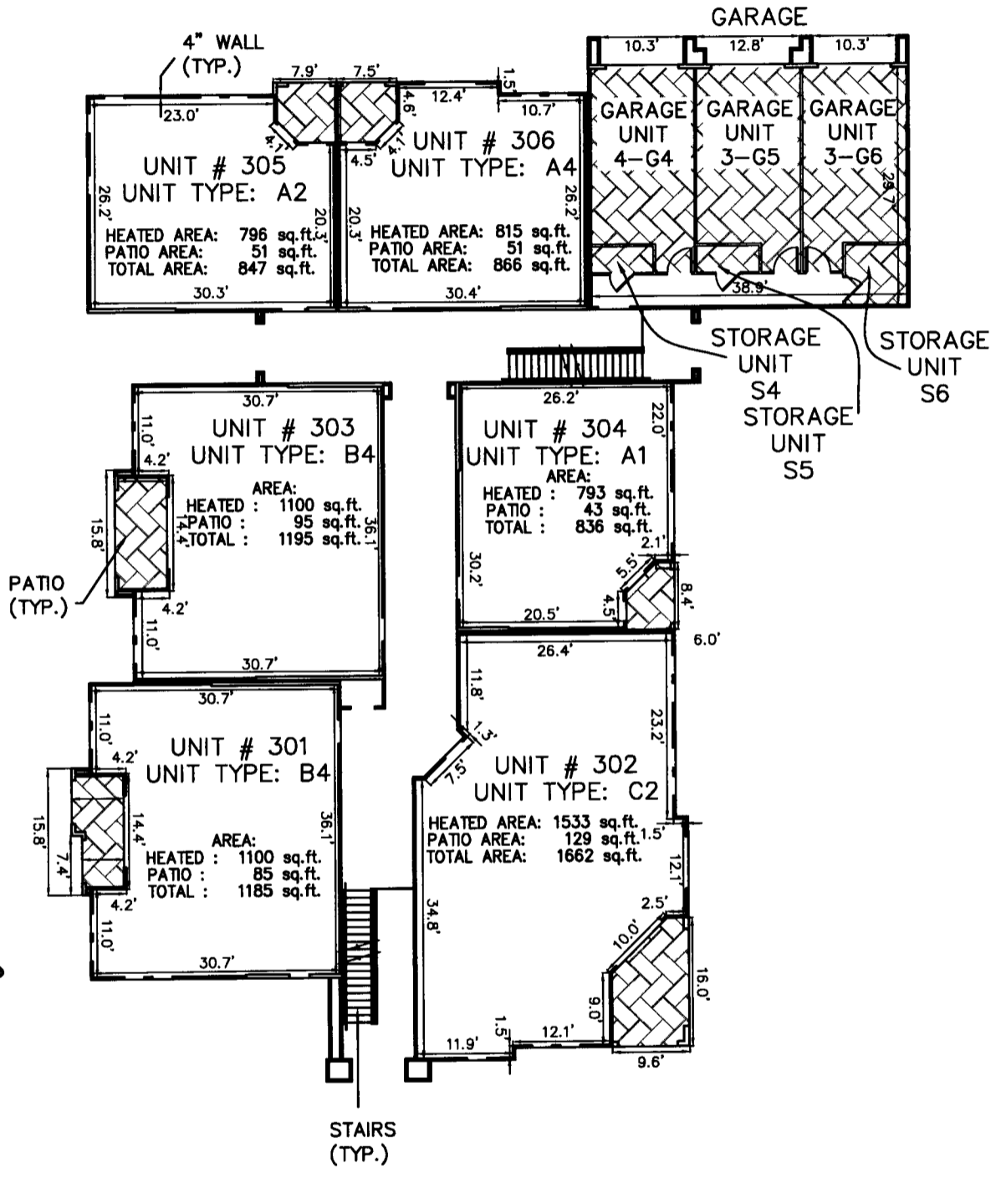

GRAPHIC SCALE



(IN FEET)
1 INCH = 20 FEET



LIMITED COMMON ELEMENT

MILLER LEGG

South Florida Office: 1800 North Douglas Road · Suite 200
Pembroke Pines, Florida · 33024-3200
954-438-7000 · Fax: 954-438-9884
www.millerlegg.com

Certificate of Authorization L.B. 6680

THIS SKETCH DOES NOT REPRESENT A BOUNDARY SURVEY

EXHIBIT

PROJECT NO.
05-00436

FILE NO.
11-1C-280

EXHIBIT A TO THE DECLARATION OF CONDOMINIUM GARDENS OF BRIDGEHAMPTON, A CONDOMINIUM

BUILDING #3 SECOND FLOOR

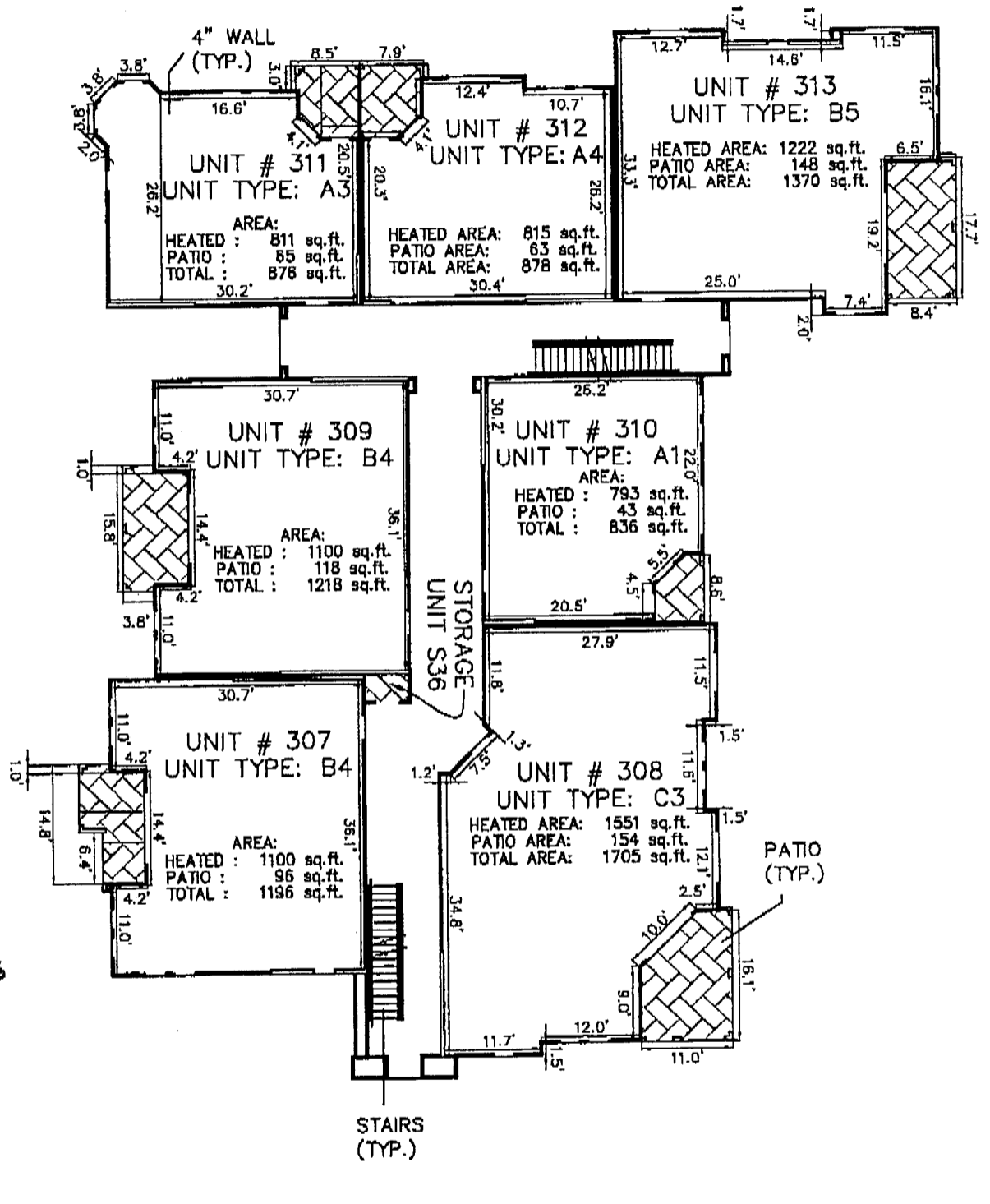

GRAPHIC SCALE

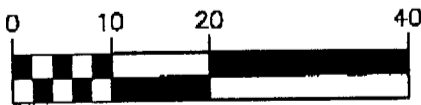

(IN FEET)
1 INCH = 20 FEET



LIMITED COMMON ELEMENT

MILLER LEGG

South Florida Office: 1800 North Douglas Road - Suite 200
Pembroke Pines, Florida - 33024-3200
954-430-7000 - Fax: 954-438-8884
www.millerlegg.com

Certificate of Authorization L.B. 6680

THIS SKETCH DOES NOT REPRESENT A BOUNDARY SURVEY

EXHIBIT

PROJECT NO.
05-00436

FAC NO.
11-1C-280

EXHIBIT A TO THE DECLARATION OF CONDOMINIUM GARDENS OF BRIDGEHAMPTON, A CONDOMINIUM

BUILDING #3

THIRD FLOOR

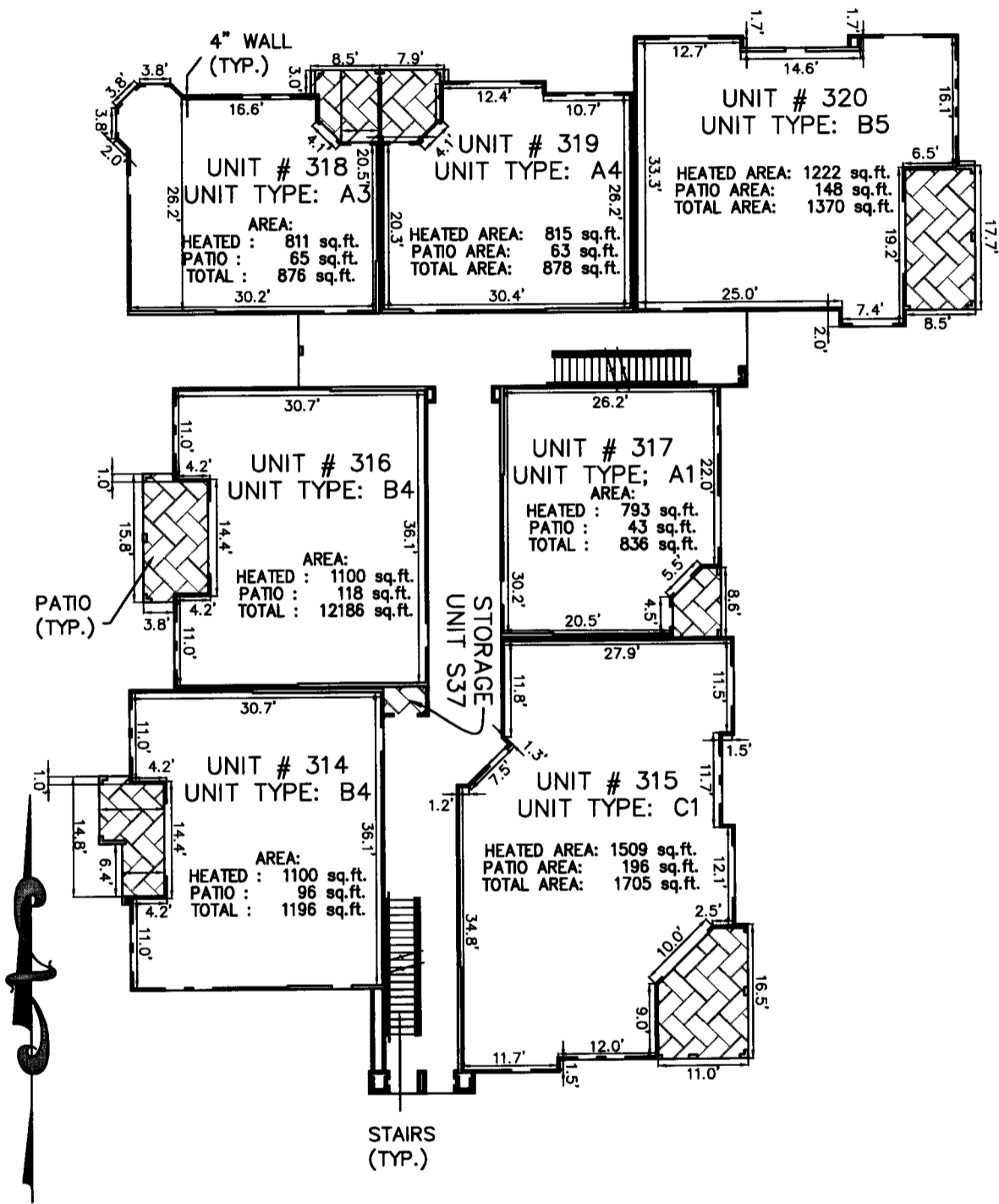

GRAPHIC SCALE



(IN FEET)
1 INCH = 20 FEET



LIMITED COMMON ELEMENT

MILLER LEGG

South Florida Office: 1800 North Douglas Road - Suite 200
Pembroke Pines, Florida - 33024-3200
954-436-7000 - Fax: 954-436-8664
www.millerlegg.com

Certificate of Authorization L.B. 6680

THIS SKETCH DOES NOT REPRESENT A BOUNDARY SURVEY

EXHIBIT

PROJECT NO.
05-00436

FILE NO.
11-1C-280

EXHIBIT A TO THE DECLARATION OF CONDOMINIUM GARDENS OF BRIDGEHAMPTON, A CONDOMINIUM

BUILDING #4 FIRST FLOOR

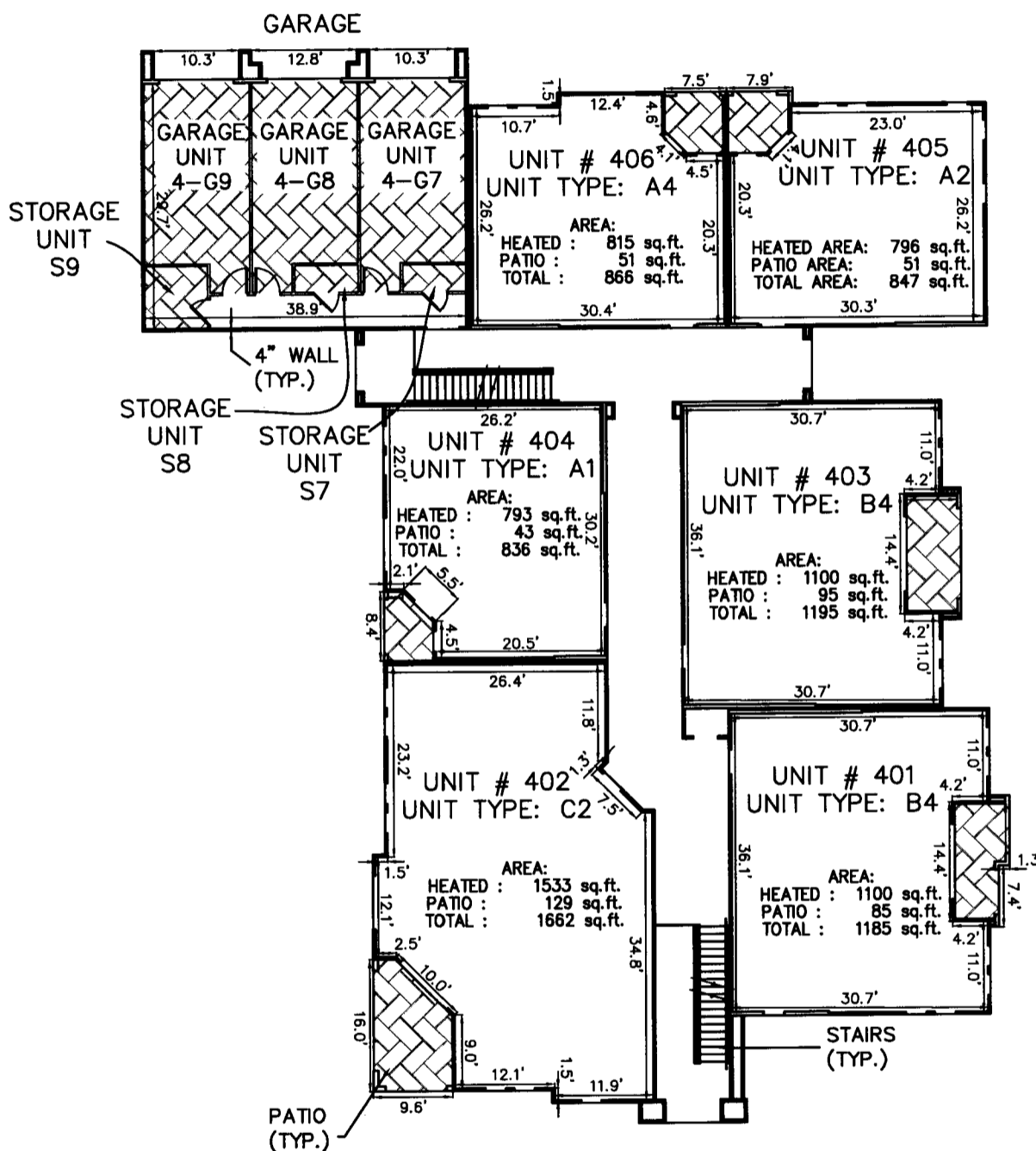

GRAPHIC SCALE



(IN FEET)
1 INCH = 20 FEET



LIMITED COMMON ELEMENT

MILLER LEGG
South Florida Office: 1800 North Douglas Road · Suite 200
Pembroke Pines, Florida · 33024-3200
954-436-7000 · Fax: 954-436-8684
www.millerlegg.com

Certificate of Authorization L.B. 6680

THIS SKETCH DOES NOT REPRESENT A BOUNDARY SURVEY

EXHIBIT

PROJECT NO.
05-00436

FILE NO.
11-1C-280

EXHIBIT A TO THE DECLARATION OF CONDOMINIUM GARDENS OF BRIDGEHAMPTON, A CONDOMINIUM

BUILDING #4 SECOND FLOOR

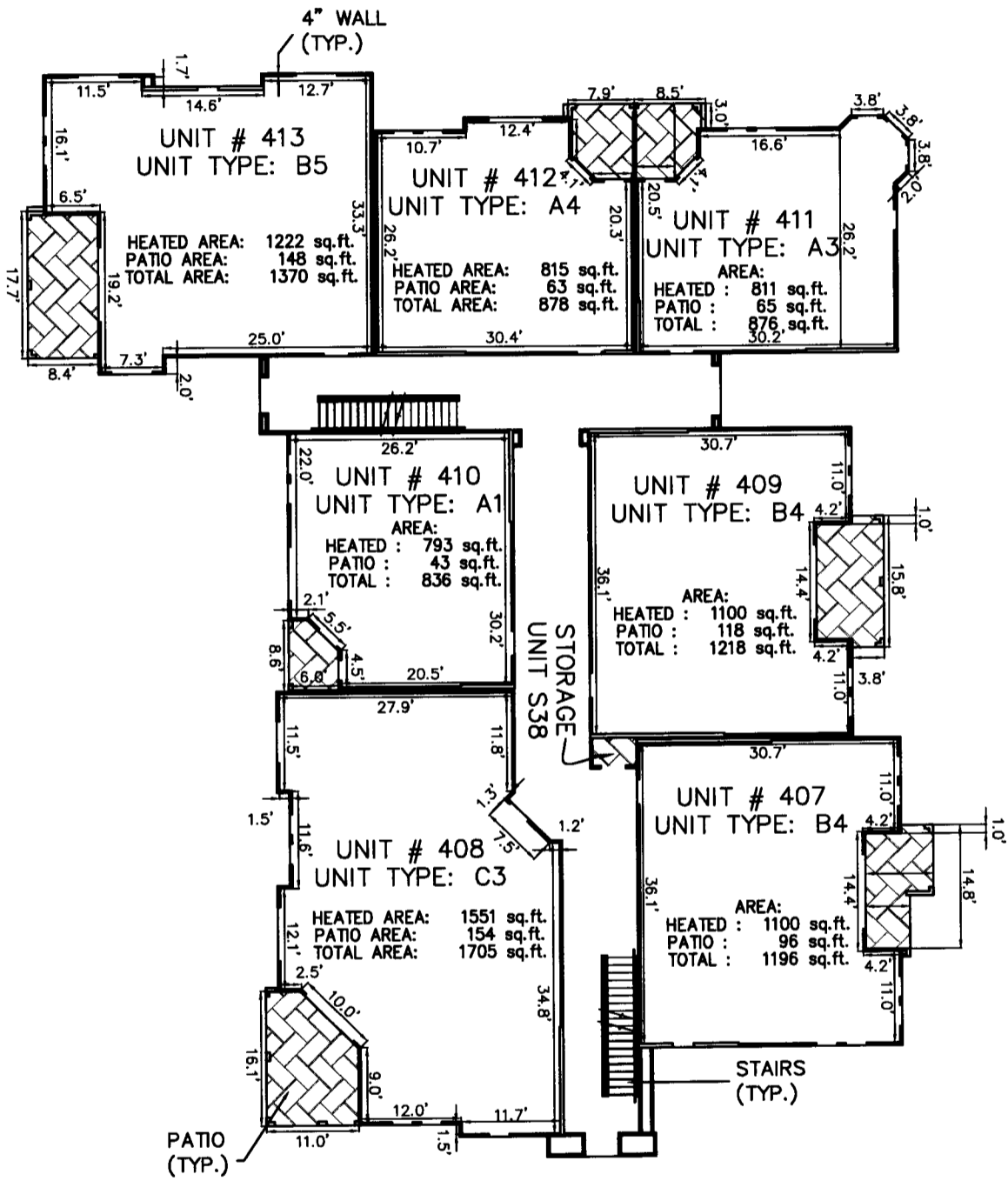

GRAPHIC SCALE



(IN FEET)
1 INCH = 20 FEET



LIMITED COMMON ELEMENT

MILLER LEGG

South Florida Office: 1800 North Douglas Road - Suite 200
Pembroke Pines, Florida - 33024-3200
954-436-7000 - Fax: 954-436-8684
www.millerlegg.com

Certificate of Authorization L.B. 6680

THIS SKETCH DOES NOT REPRESENT A BOUNDARY SURVEY

EXHIBIT

PROJECT NO.
05-00436

FILE NO.
11-1C-280

EXHIBIT A TO THE DECLARATION OF CONDOMINIUM GARDENS OF BRIDGEHAMPTON, A CONDOMINIUM

BUILDING #4 THIRD FLOOR

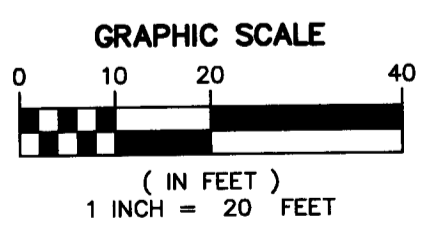
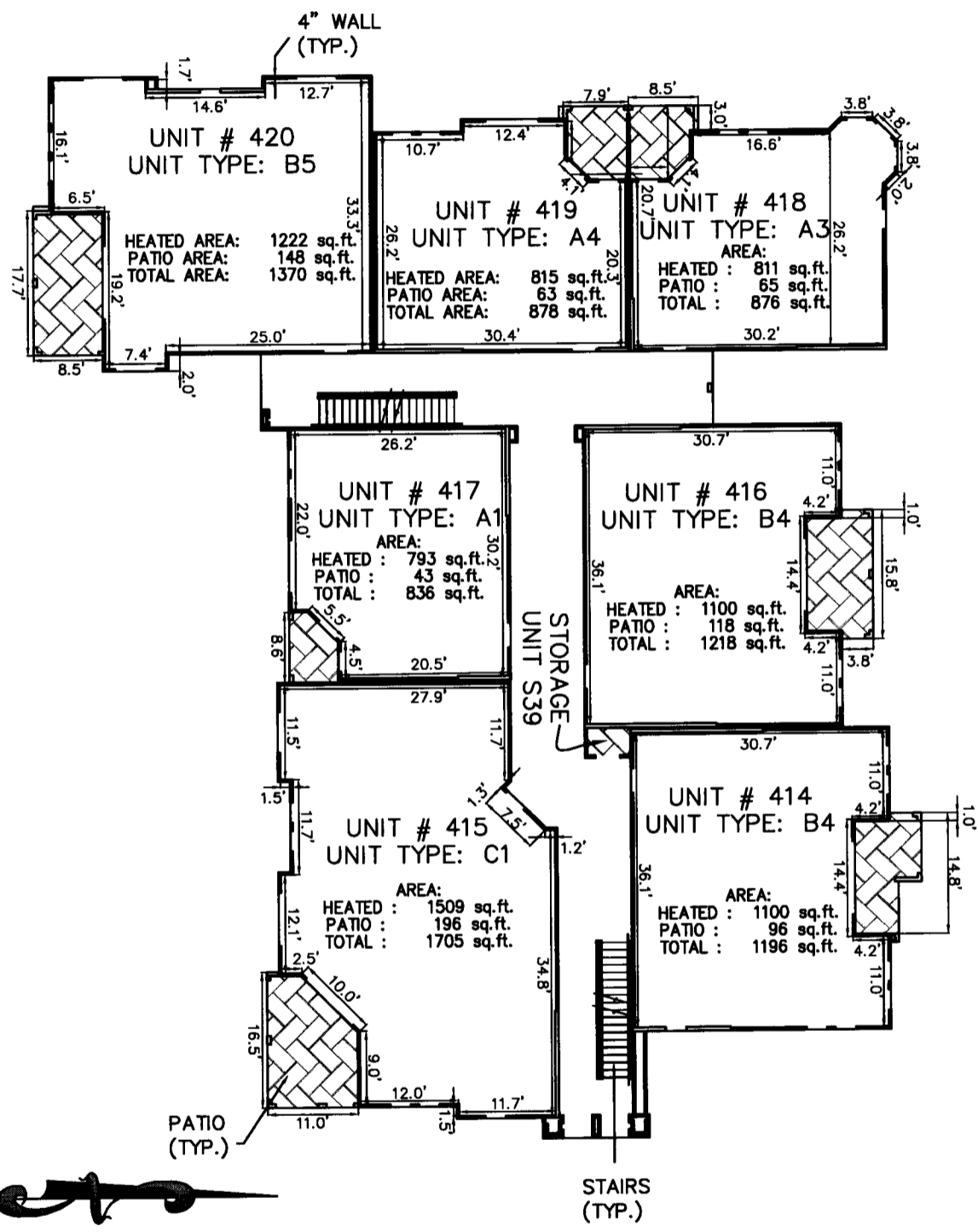

LIMITED COMMON ELEMENT

MILLER LEGG
South Florida Office: 1800 North Douglas Road · Suite 200
Pembroke Pines, Florida · 33024-3200
954-436-7000 · Fax: 954-436-8664
www.millerlegg.com

Certificate of Authorization L.B. 6680

THIS SKETCH DOES NOT REPRESENT A BOUNDARY SURVEY

EXHIBIT

PROJECT NO.
05-00436

FILE NO.
11-1C-280

EXHIBIT A TO THE DECLARATION OF CONDOMINIUM GARDENS OF BRIDGEHAMPTON, A CONDOMINIUM

BUILDING #5 FIRST FLOOR

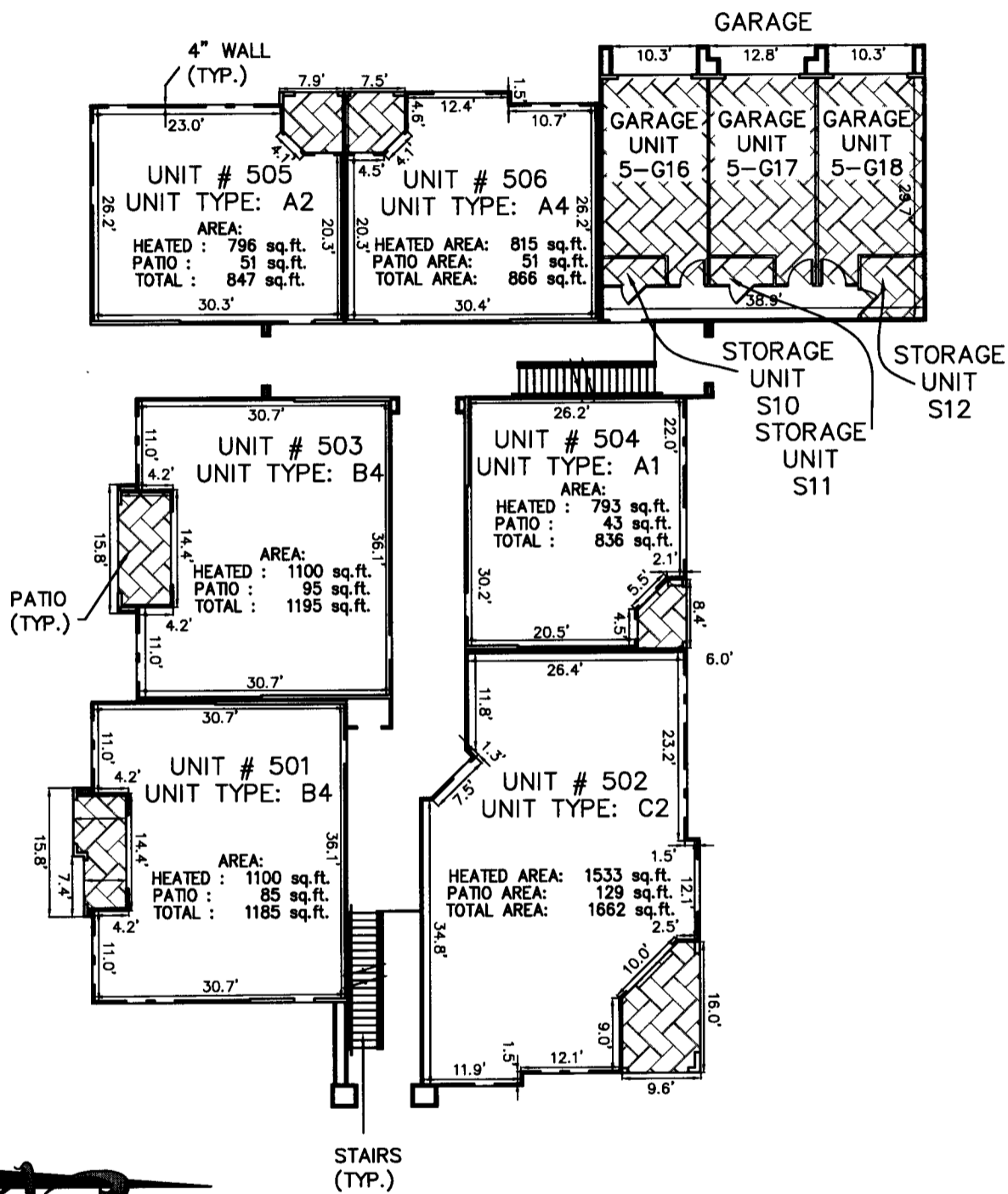

GRAPHIC SCALE



(IN FEET)
1 INCH = 20 FEET



LIMITED COMMON ELEMENT

MILLER LEGG

South Florida Office: 1800 North Douglas Road · Suite 200
Pembroke Pines, Florida · 33024-3200
954-436-7000 · Fax: 954-436-8664
www.millerlegg.com

Certificate of Authorization L.B. 6680

THIS SKETCH DOES NOT REPRESENT A BOUNDARY SURVEY

EXHIBIT

PROJECT NO.

05-00436

FILE NO.

11-1C-280

EXHIBIT A TO THE DECLARATION OF CONDOMINIUM GARDENS OF BRIDGEHAMPTON, A CONDOMINIUM

BUILDING #5 SECOND FLOOR

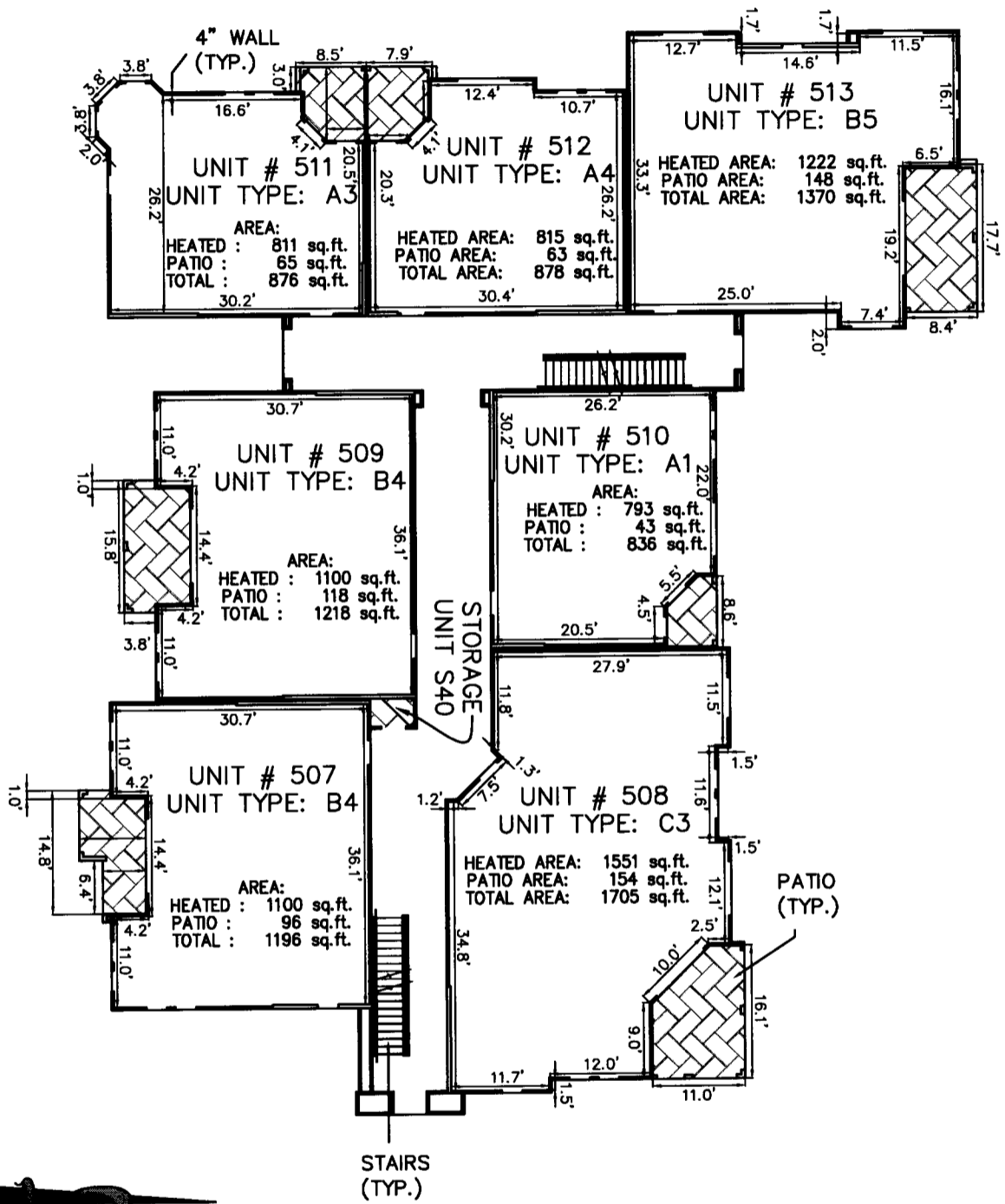

GRAPHIC SCALE



(IN FEET)
1 INCH = 20 FEET



LIMITED COMMON ELEMENT

MILLER LEGG

South Florida Office: 1800 North Douglas Road - Suite 200
Pembroke Pines, Florida - 33024-3200
954-438-7000 · Fax: 954-438-8664
www.millerlegg.com

Certificate of Authorization L.B. 6680

THIS SKETCH DOES NOT REPRESENT A BOUNDARY SURVEY

EXHIBIT

PROJECT NO.
05-00436

FILE NO.
11-1C-280

EXHIBIT A TO THE DECLARATION OF CONDOMINIUM GARDENS OF BRIDGEHAMPTON, A CONDOMINIUM

BUILDING #5 THIRD FLOOR

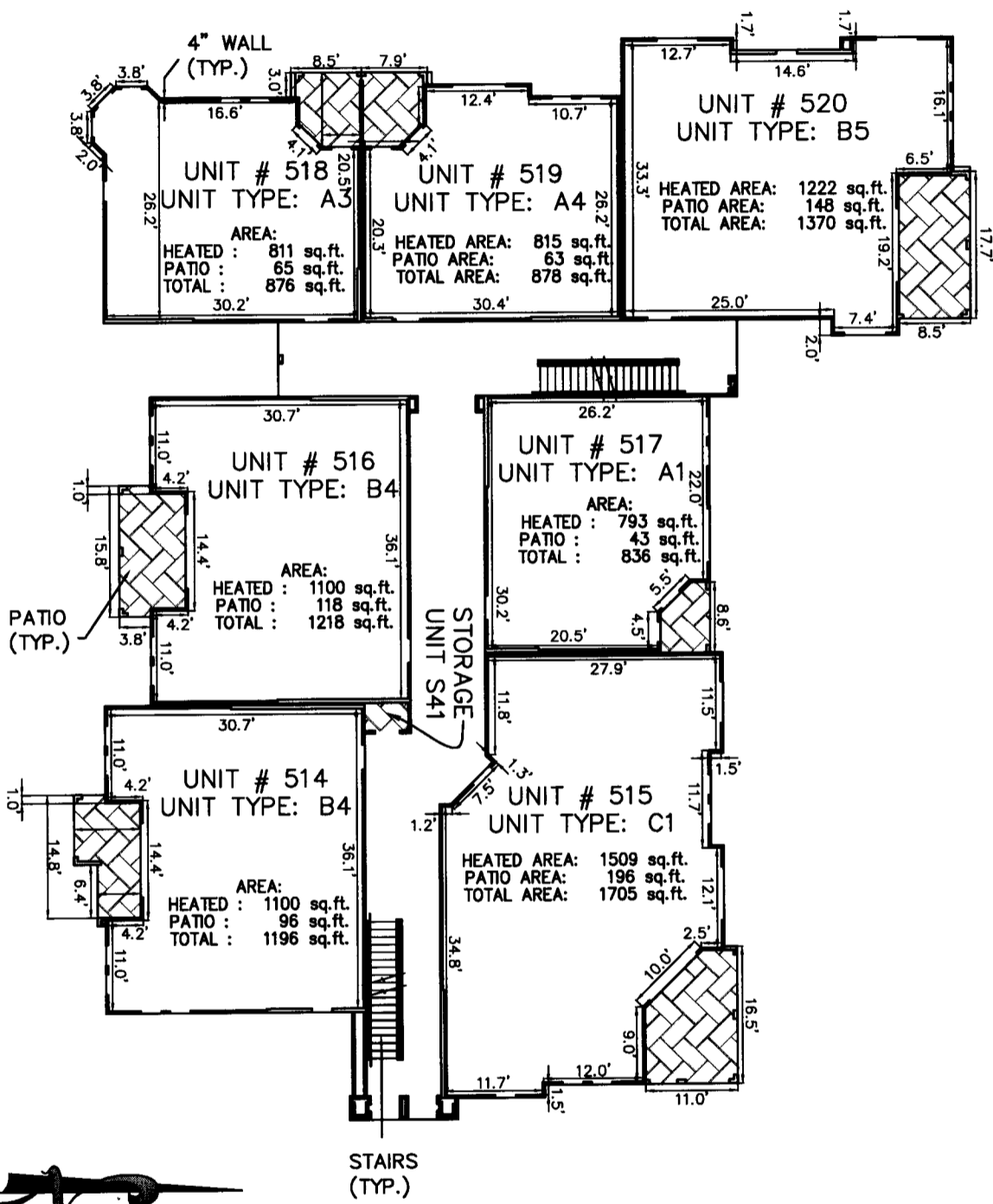

GRAPHIC SCALE

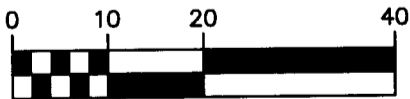

(IN FEET)
1 INCH = 20 FEET



LIMITED COMMON ELEMENT

MILLER LEGG

South Florida Offices: 1800 North Douglas Road - Suite 200
Pembroke Pines, Florida - 33024-3200
954-436-7000 - Fax: 954-436-8664
www.millerlegg.com

Certificate of Authorization L.B. 6680

THIS SKETCH DOES NOT REPRESENT A BOUNDARY SURVEY

EXHIBIT

PROJECT NO.
05-00436

FILE NO.
11-1C-280

EXHIBIT A TO THE DECLARATION OF CONDOMINIUM GARDENS OF BRIDGEHAMPTON, A CONDOMINIUM

BUILDING #6

FIRST FLOOR

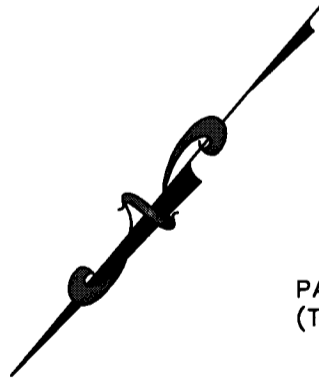
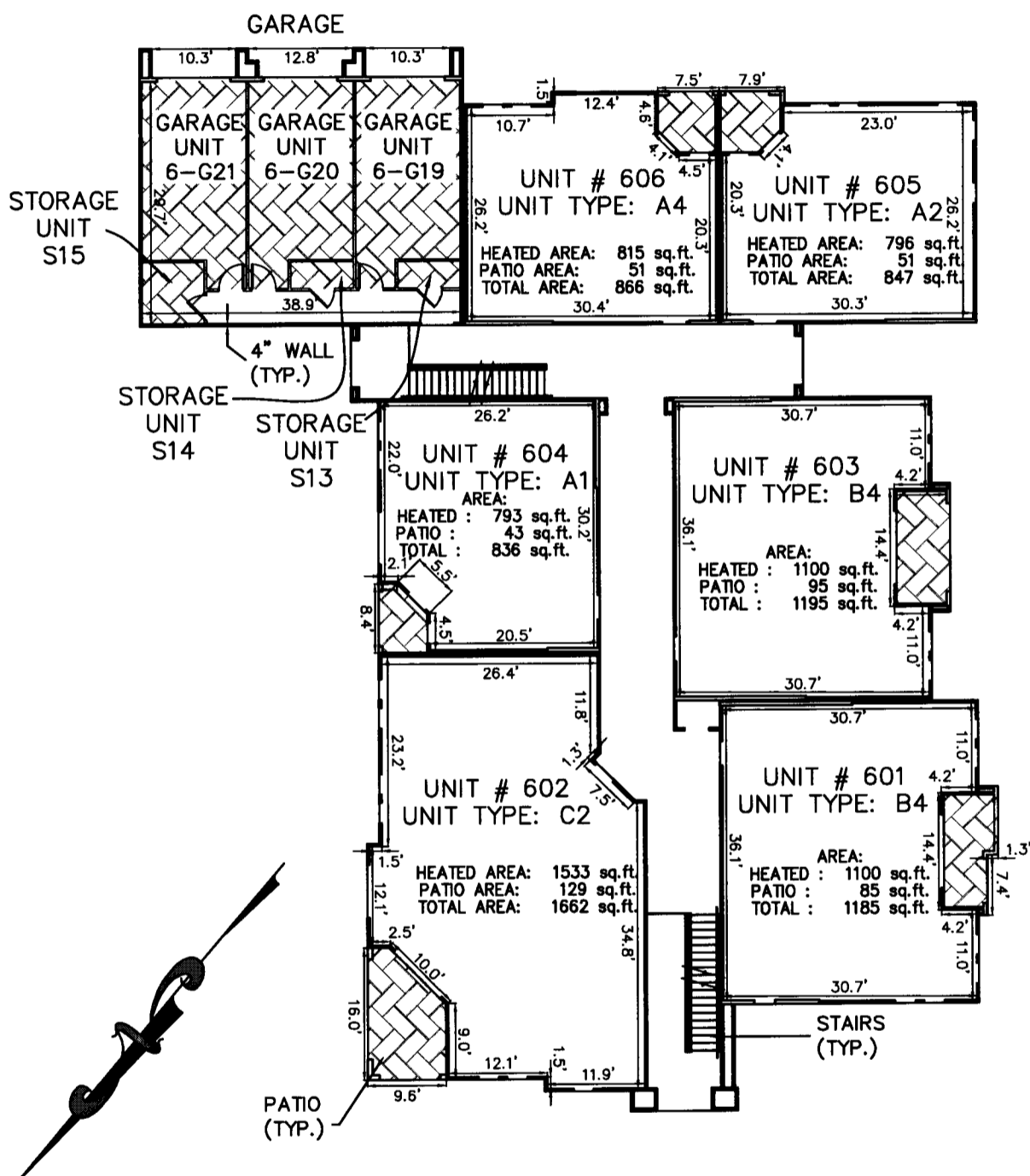

GRAPHIC SCALE



(IN FEET)
1 INCH = 20 FEET



LIMITED COMMON ELEMENT

MILLER LEGG

South Florida Office: 1800 North Douglas Road - Suite 200
Pembroke Pines, Florida - 33024-3200
954-436-7000 - Fax: 954-436-8664
www.millerlegg.com

Certificate of Authorization L.B. 6680

THIS SKETCH DOES NOT REPRESENT A BOUNDARY SURVEY

EXHIBIT

PROJECT NO.
05-00436

FILE NO.
11-1C-280

EXHIBIT A TO THE DECLARATION OF CONDOMINIUM GARDENS OF BRIDGEHAMPTON, A CONDOMINIUM

BUILDING #6 SECOND FLOOR

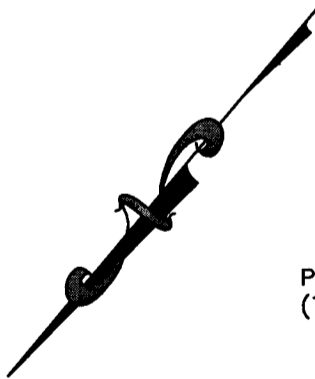
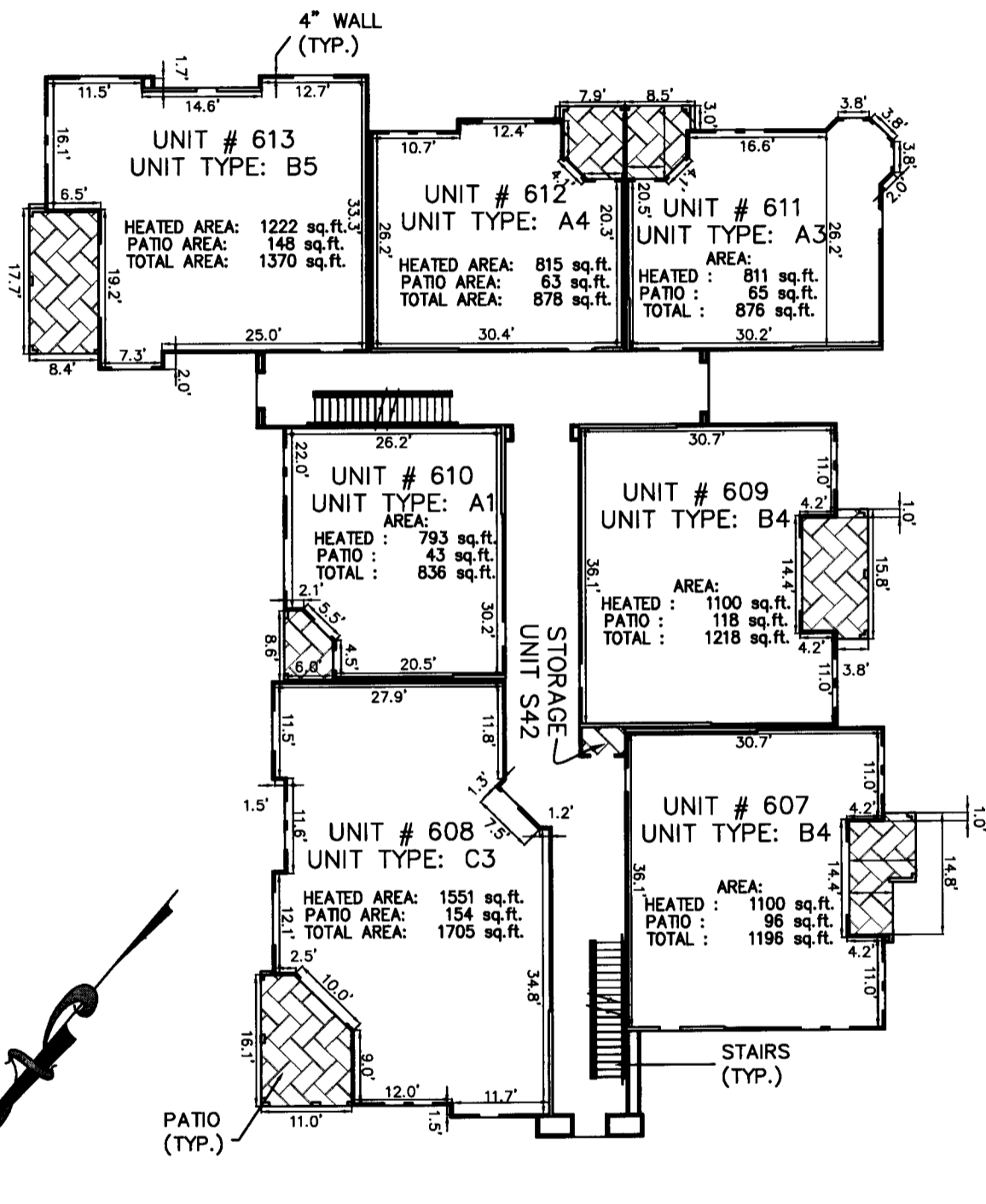

GRAPHIC SCALE



(IN FEET)
1 INCH = 20 FEET



LIMITED COMMON ELEMENT

MILLER LEGG

South Florida Office: 1800 North Douglas Road - Suite 200
Pembroke Pines, Florida - 33024-3200
954-436-7000 - Fax: 954-436-8664
www.millerlegg.com

Certificate of Authorization L.B. 6680

THIS SKETCH DOES NOT REPRESENT A BOUNDARY SURVEY

EXHIBIT

PROJECT NO.
05-00436

FILE NO.
11-1C-280

EXHIBIT A TO THE DECLARATION OF CONDOMINIUM GARDENS OF BRIDGEHAMPTON, A CONDOMINIUM

BUILDING #6 THIRD FLOOR

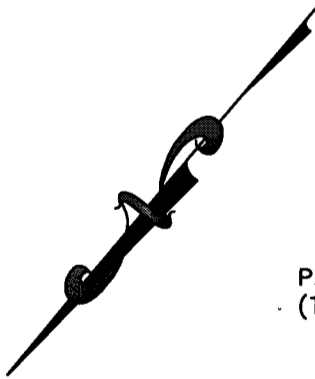
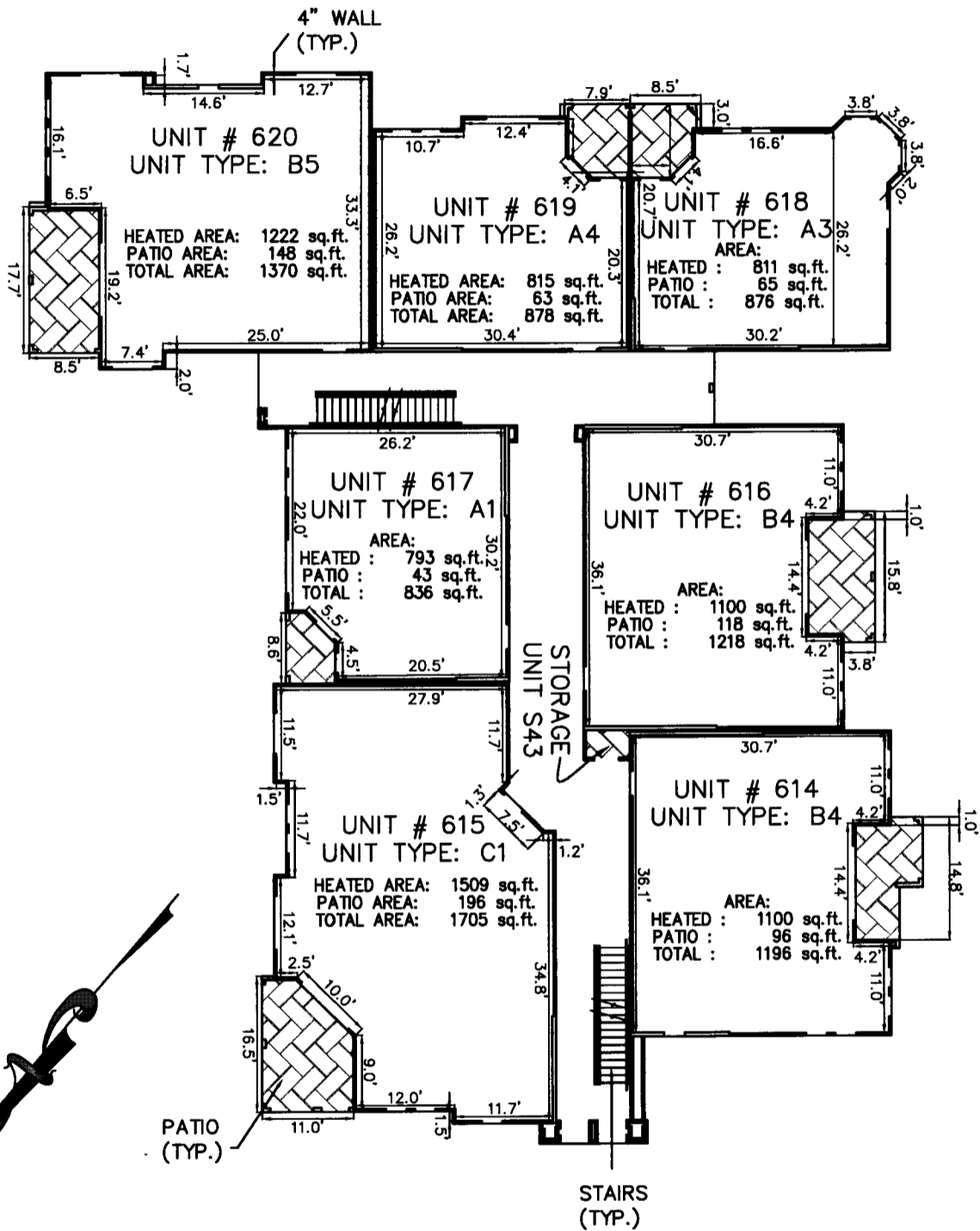

GRAPHIC SCALE



(IN FEET)
1 INCH = 20 FEET



LIMITED COMMON ELEMENT

MILLER LEGG

South Florida Office: 1800 North Douglas Road - Suite 200
Pembroke Pines, Florida - 33024-3200
954-436-7000 - Fax: 954-436-8664
www.millerlegg.com

Certificate of Authorization L.B. 6680

THIS SKETCH DOES NOT REPRESENT A BOUNDARY SURVEY

EXHIBIT

PROJECT NO.
05-00436

FILE NO.
11-1C-280

EXHIBIT A TO THE DECLARATION OF CONDOMINIUM GARDENS OF BRIDGEHAMPTON, A CONDOMINIUM

BUILDING #7 FIRST FLOOR

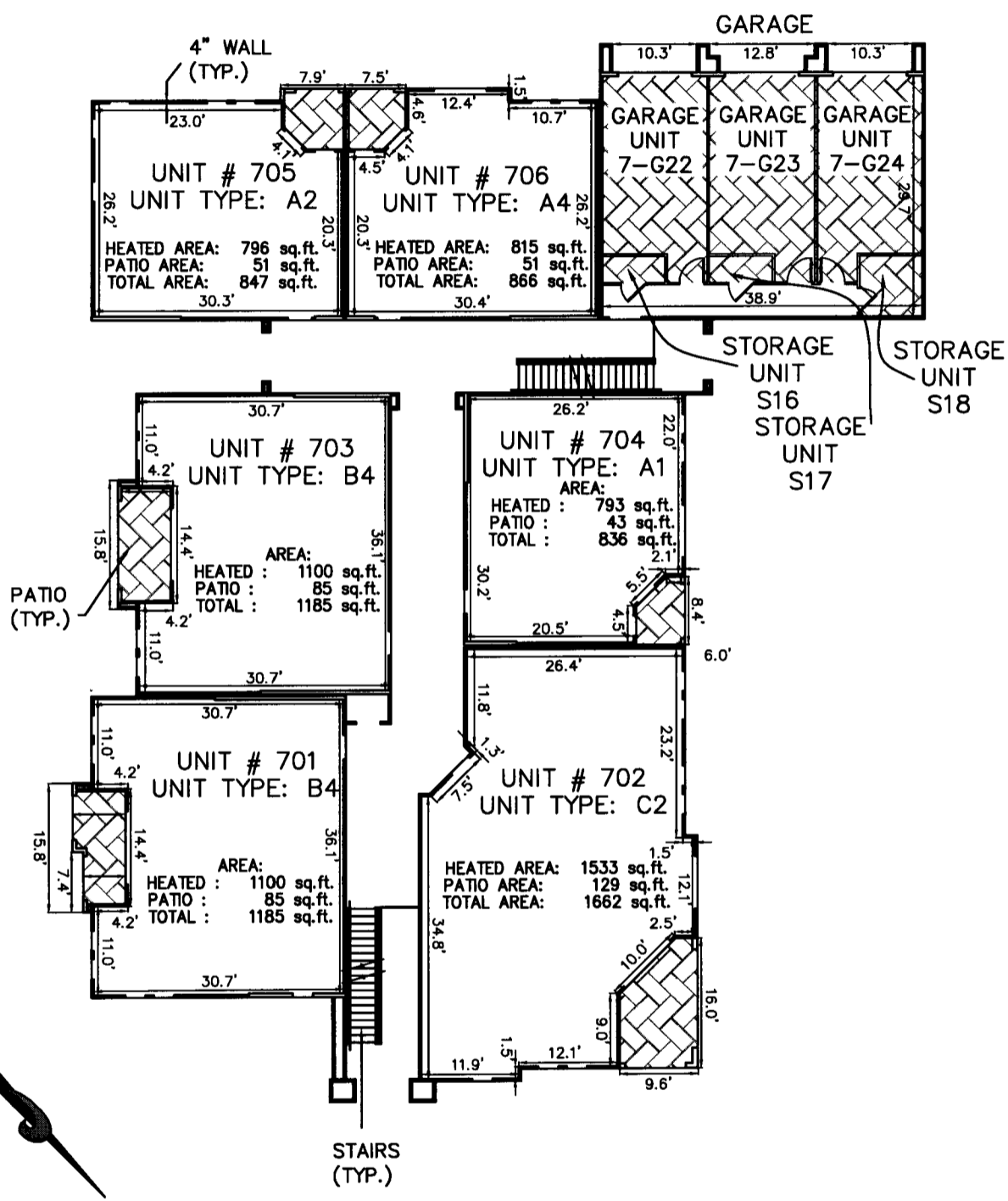

GRAPHIC SCALE



(IN FEET)
1 INCH = 20 FEET



LIMITED COMMON ELEMENT



South Florida Office: 1800 North Douglas Road - Suite 200
Pembroke Pines, Florida - 33024-3200
954-436-7000 - Fax: 954-436-8864
www.millerlegg.com

Certificate of Authorization L.B. 6680

THIS SKETCH DOES NOT REPRESENT A BOUNDARY SURVEY

EXHIBIT

PROJECT NO.
05-00436

FILE NO.
11-1C-280

EXHIBIT A TO THE DECLARATION OF CONDOMINIUM GARDENS OF BRIDGEHAMPTON, A CONDOMINIUM

BUILDING #7 SECOND FLOOR

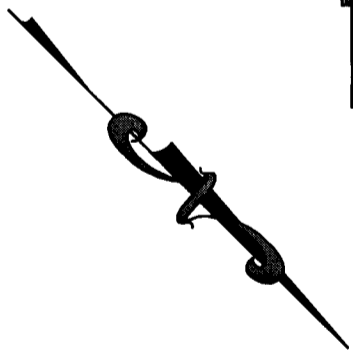
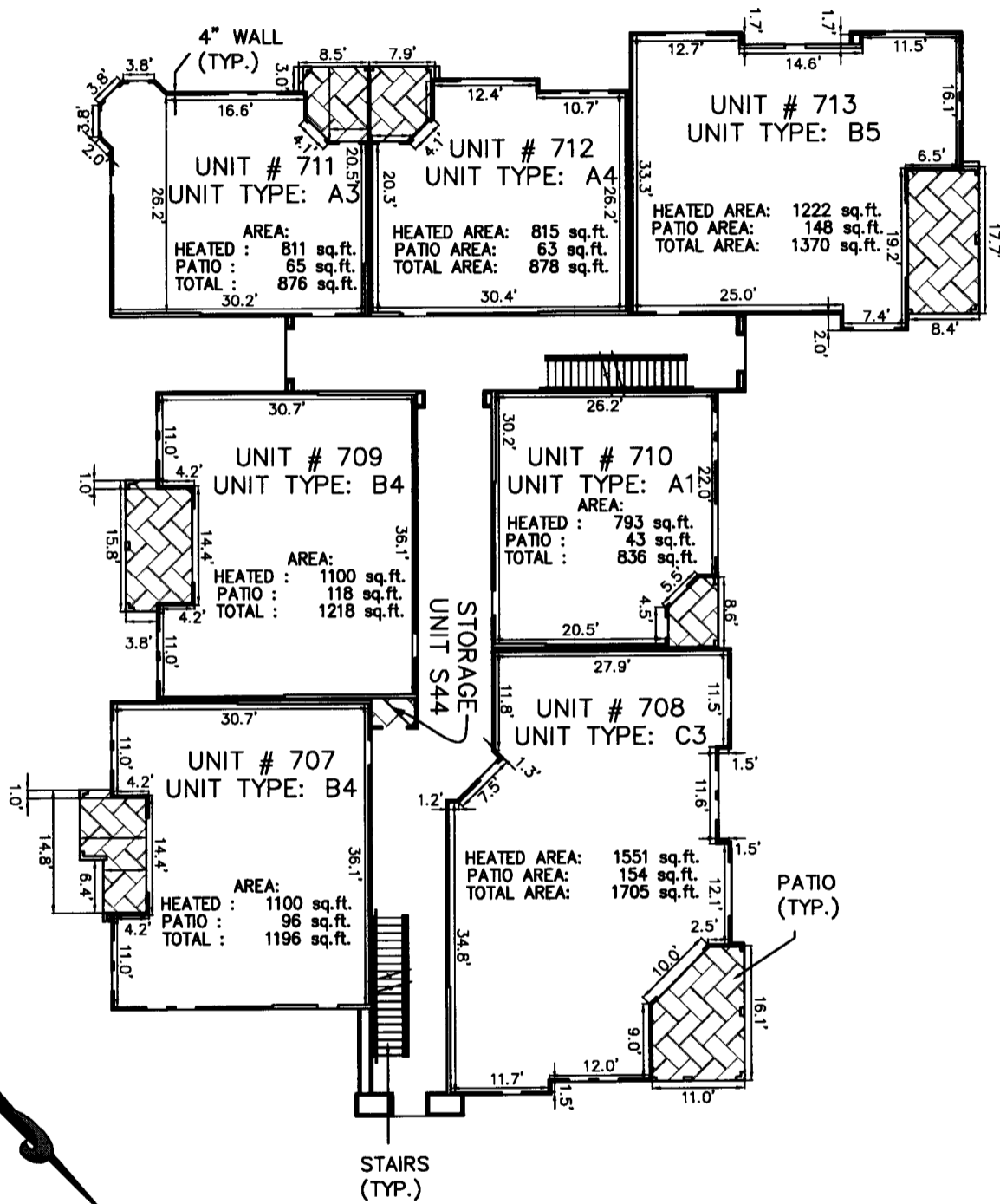

GRAPHIC SCALE



(IN FEET)
1 INCH = 20 FEET

LIMITED COMMON ELEMENT

MILLER LEGG
South Florida Office: 1800 North Douglas Road · Suite 200
Pembroke Pines, Florida · 33024-3200
954-436-7000 · Fax: 954-436-8864
www.millerlegg.com

Certificate of Authorization L.B. 6680

THIS SKETCH DOES NOT REPRESENT A BOUNDARY SURVEY

EXHIBIT

PROJECT NO.
05-00436

FILE NO.
11-1C-280

EXHIBIT A TO THE DECLARATION OF CONDOMINIUM GARDENS OF BRIDGEHAMPTON, A CONDOMINIUM

BUILDING #7 THIRD FLOOR

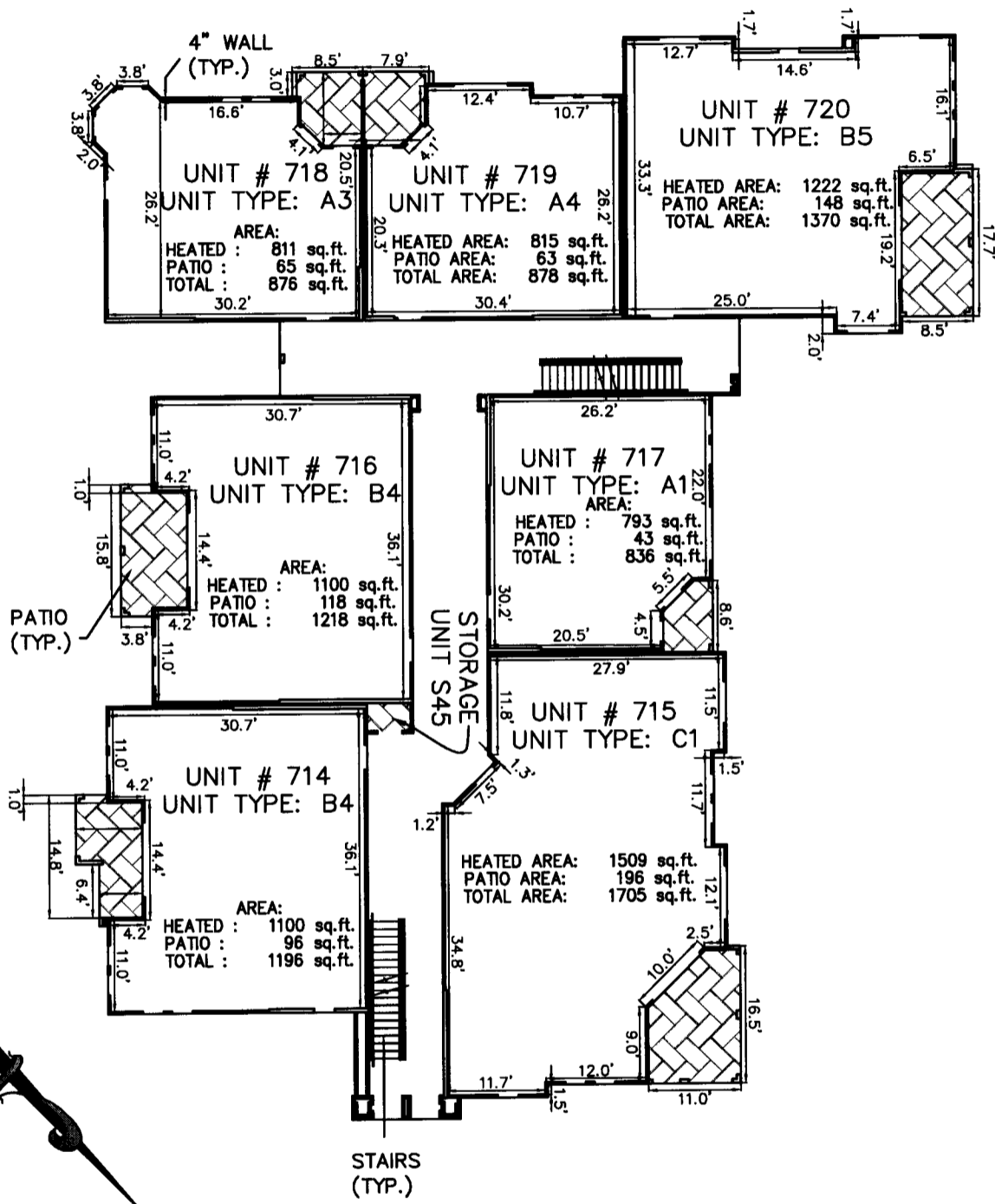

GRAPHIC SCALE



(IN FEET)
1 INCH = 20 FEET



LIMITED COMMON ELEMENT

MILLER LEGG

South Florida Office: 1800 North Douglas Road - Suite 200
Pembroke Pines, Florida - 33024-3200
954-436-7000 · Fax: 954-436-8664
www.millerlegg.com

Certificate of Authorization L.B. 6680

THIS SKETCH DOES NOT REPRESENT A BOUNDARY SURVEY

EXHIBIT

PROJECT NO.
05-00436

FILE NO.
11-1C-280

EXHIBIT A TO THE DECLARATION OF CONDOMINIUM GARDENS OF BRIDGEHAMPTON, A CONDOMINIUM

BUILDING #8 FIRST FLOOR

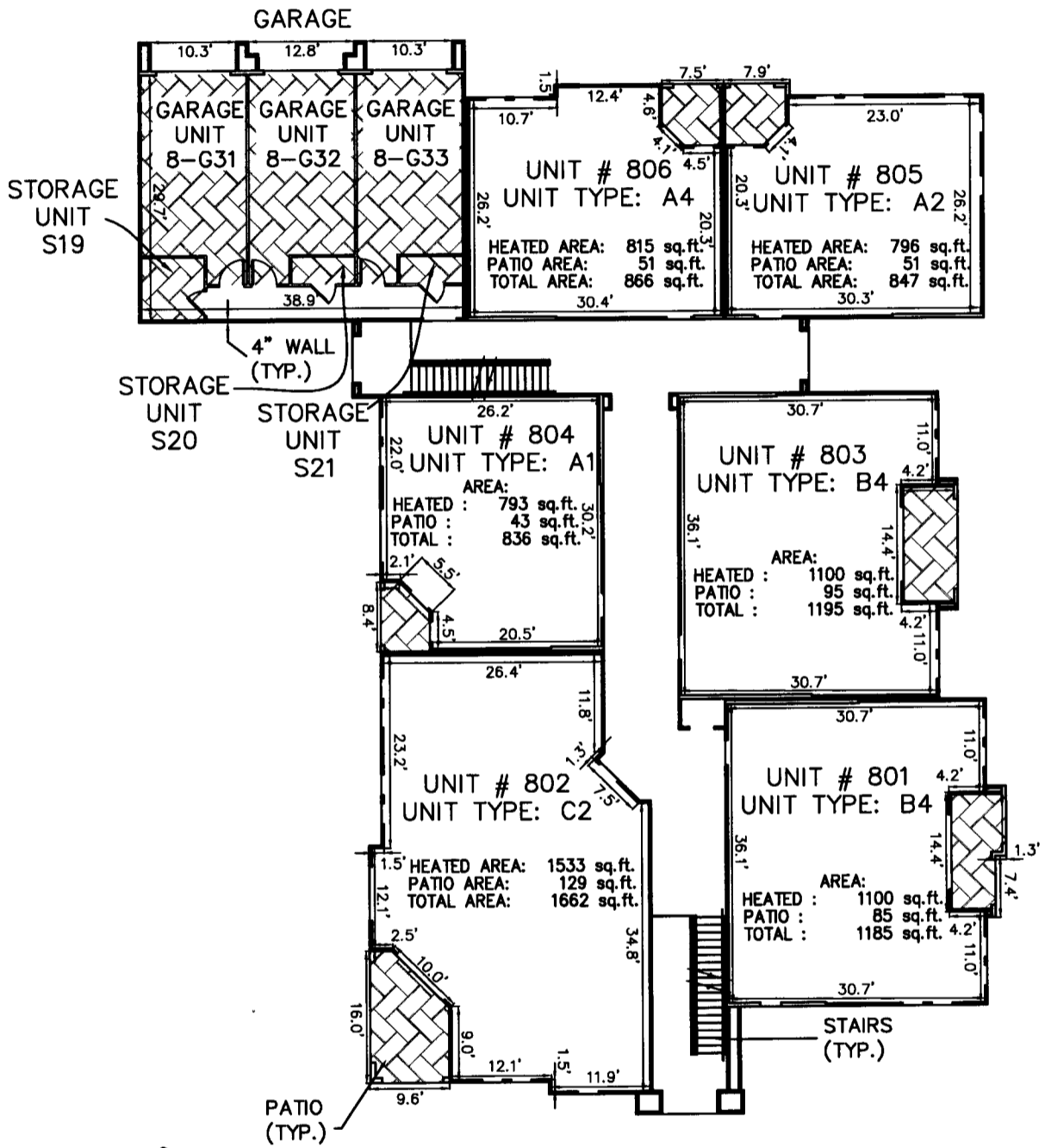

GRAPHIC SCALE



(IN FEET)
1 INCH = 20 FEET

LIMITED COMMON ELEMENT

MILLER LEGG
South Florida Office: 1800 North Douglas Road · Suite 200
Pembroke Pines, Florida · 33024-3200
954-436-7000 · Fax: 954-436-8664
www.millerlegg.com

Certificate of Authorization L.B. 6680

THIS SKETCH DOES NOT REPRESENT A BOUNDARY SURVEY

EXHIBIT

PROJECT NO.
05-00436

FILE NO.
11-1C-280

GARDENS OF BRIDGEHAMPTON, A CONDOMINIUM

BUILDING #8 SECOND FLOOR

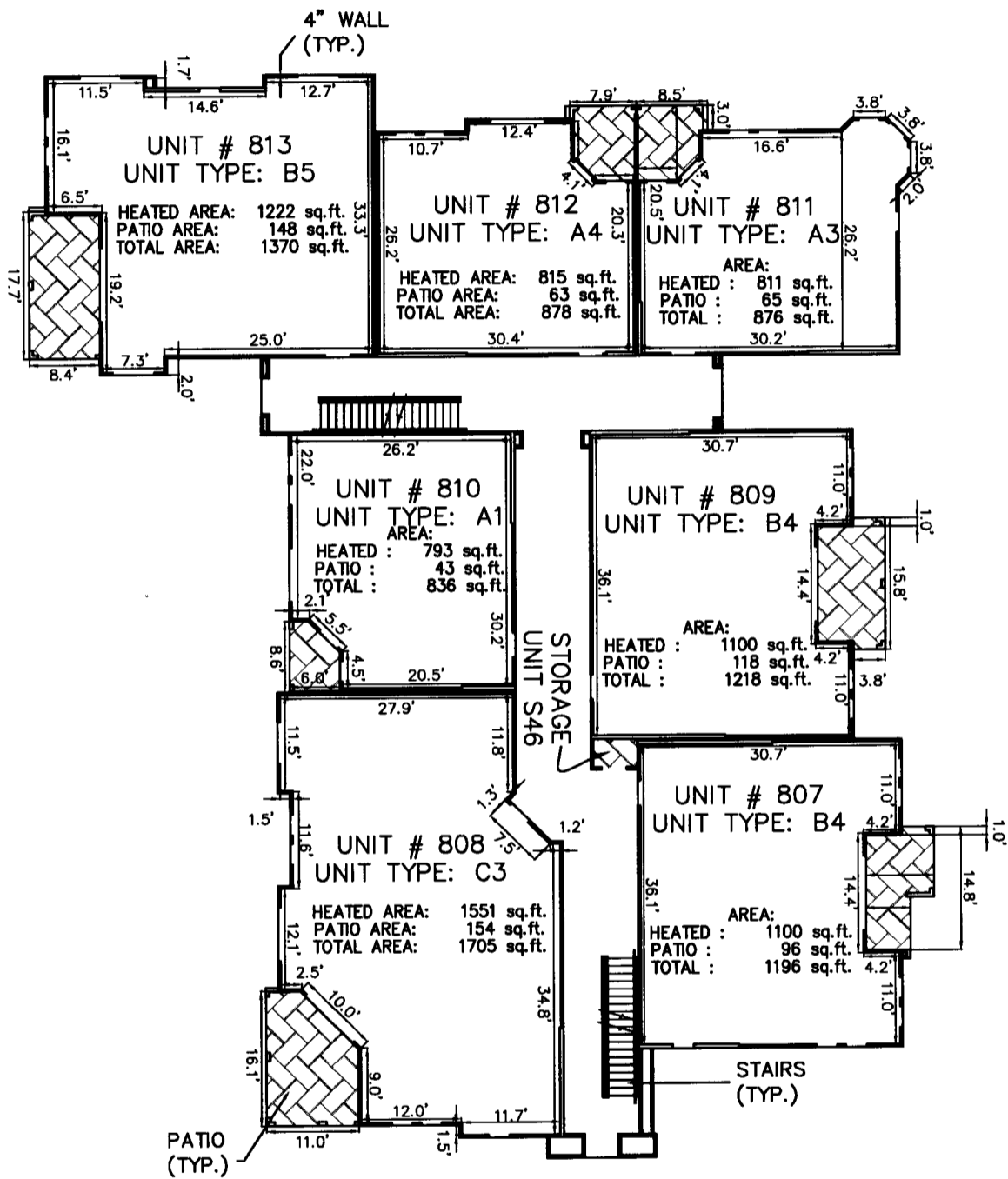

GRAPHIC SCALE



(IN FEET)
1 INCH = 20 FEET



LIMITED COMMON ELEMENT

MILLER LEGG

South Florida Office: 1800 North Douglas Road · Suite 200
Pembroke Pines, Florida · 33024-3200
954-436-7000 · Fax: 954-436-8664
www.millerlegg.com

Certificate of Authorization L.B. 6680

THIS SKETCH DOES NOT REPRESENT A BOUNDARY SURVEY

EXHIBIT

PROJECT NO.

05-00436

FILE NO.

11-1C-280

EXHIBIT A TO THE DECLARATION OF CONDOMINIUM GARDENS OF BRIDGEHAMPTON, A CONDOMINIUM

BUILDING #8 THIRD FLOOR

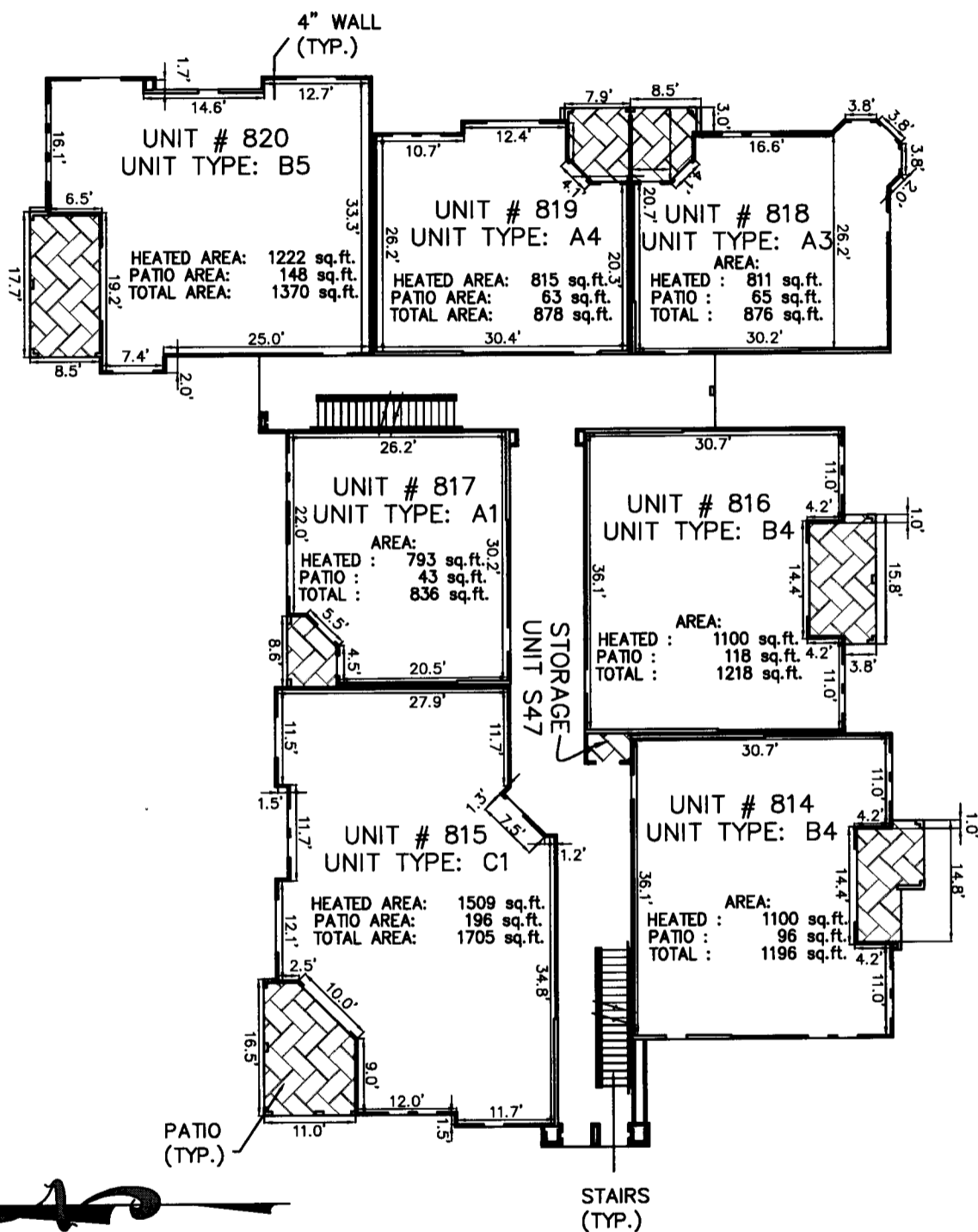

GRAPHIC SCALE



(IN FEET)
1 INCH = 20 FEET



LIMITED COMMON ELEMENT

MILLER LEGG

South Florida Office: 1800 North Douglas Road · Suite 200
Pembroke Pines, Florida · 33024-3200
954-436-7000 · Fax: 954-436-8664
www.millerlegg.com

Certificate of Authorization L.B. 6680

THIS SKETCH DOES NOT REPRESENT A BOUNDARY SURVEY

EXHIBIT

PROJECT NO.
05-00436

FILE NO.
11-1C-280

EXHIBIT A TO THE DECLARATION OF CONDOMINIUM GARDENS OF BRIDGEHAMPTON, A CONDOMINIUM

BUILDING #9 FIRST FLOOR

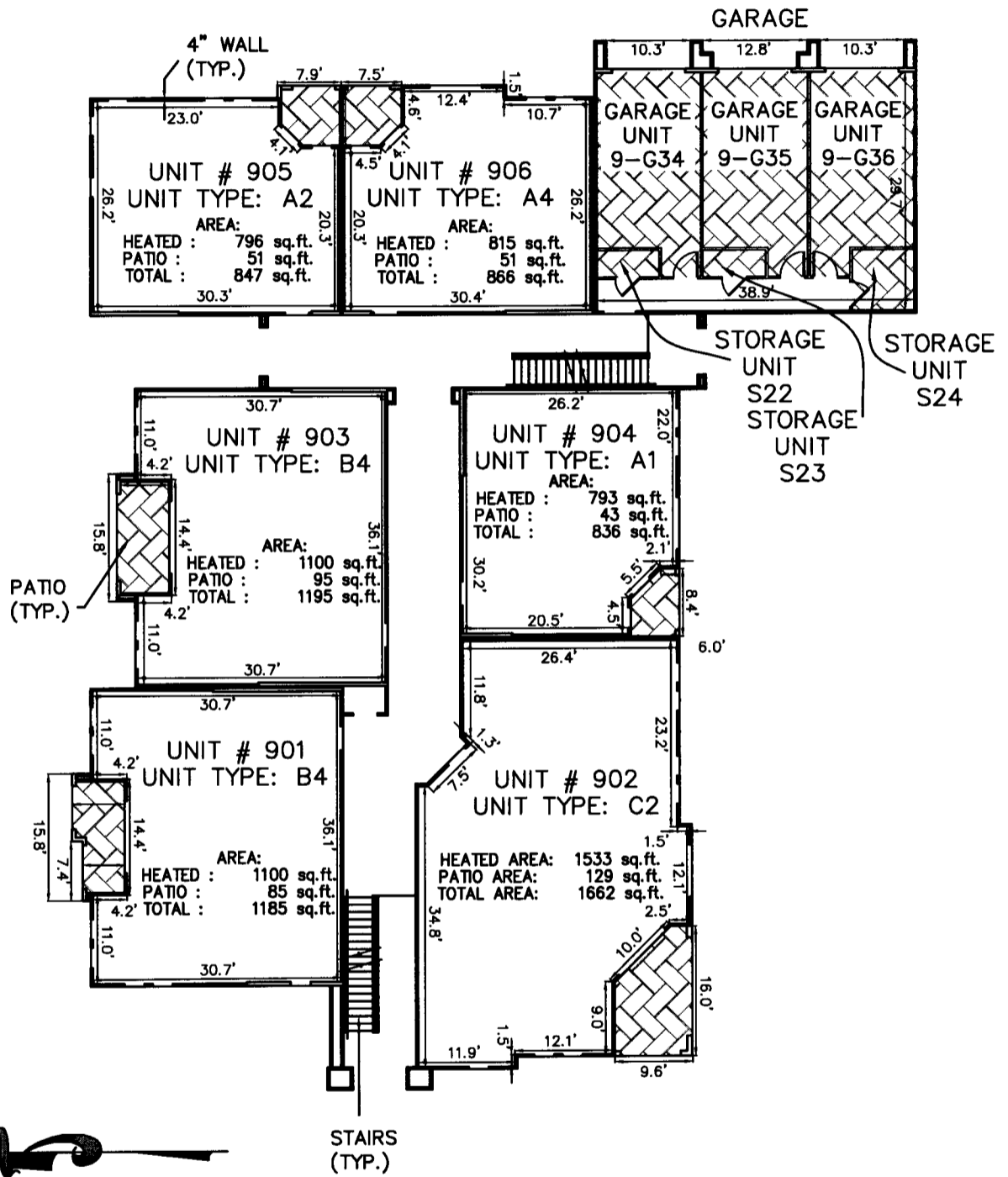

GRAPHIC SCALE



(IN FEET)
1 INCH = 20 FEET

LIMITED COMMON ELEMENT

MILLER LEGG

South Florida Office: 1800 North Douglas Road - Suite 200
Pembroke Pines, Florida : 33024-3200
954-436-7000 · Fax: 954-436-8664
www.millerlegg.com

Certificate of Authorization L.B. 6680

THIS SKETCH DOES NOT REPRESENT A BOUNDARY SURVEY

EXHIBIT

PROJECT NO.
05-00436

FILE NO.
11-1C-280

EXHIBIT A TO THE DECLARATION OF CONDOMINIUM GARDENS OF BRIDGEHAMPTON, A CONDOMINIUM

BUILDING #9 SECOND FLOOR

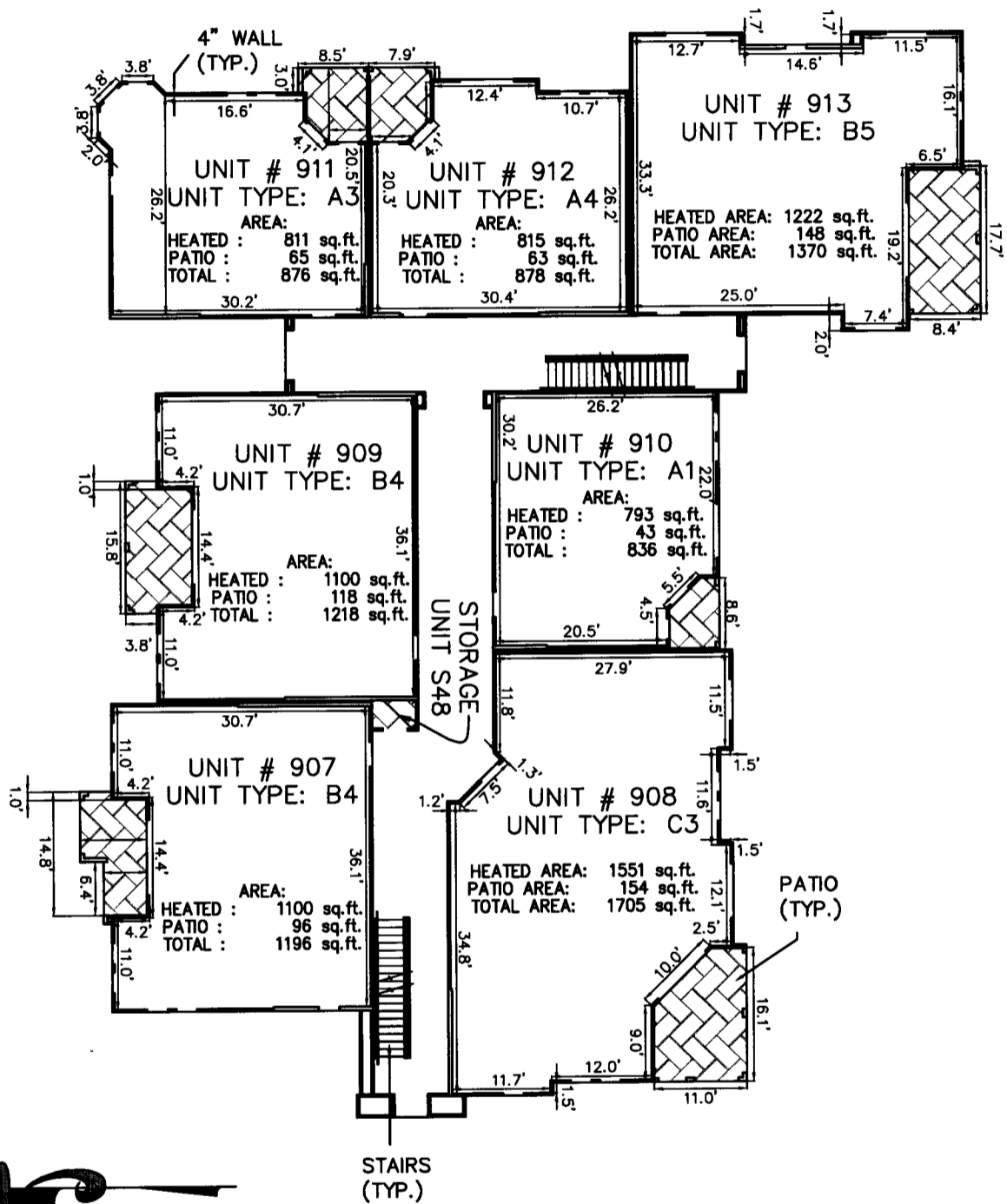

GRAPHIC SCALE



(IN FEET)
1 INCH = 20 FEET



LIMITED COMMON ELEMENT

MILLER LEGG

South Florida Office: 1800 North Douglas Road · Suite 200
Pembroke Pines, Florida · 33024-3200
954-436-7000 · Fax: 954-436-8664
www.millerlegg.com

Certificate of Authorization L.B. 6680

THIS SKETCH DOES NOT REPRESENT A BOUNDARY SURVEY

EXHIBIT

PROJECT NO.
05-00436

FILE NO.
11-1C-280

EXHIBIT A TO THE DECLARATION OF CONDOMINIUM GARDENS OF BRIDGEHAMPTON, A CONDOMINIUM

BUILDING #9 THIRD FLOOR

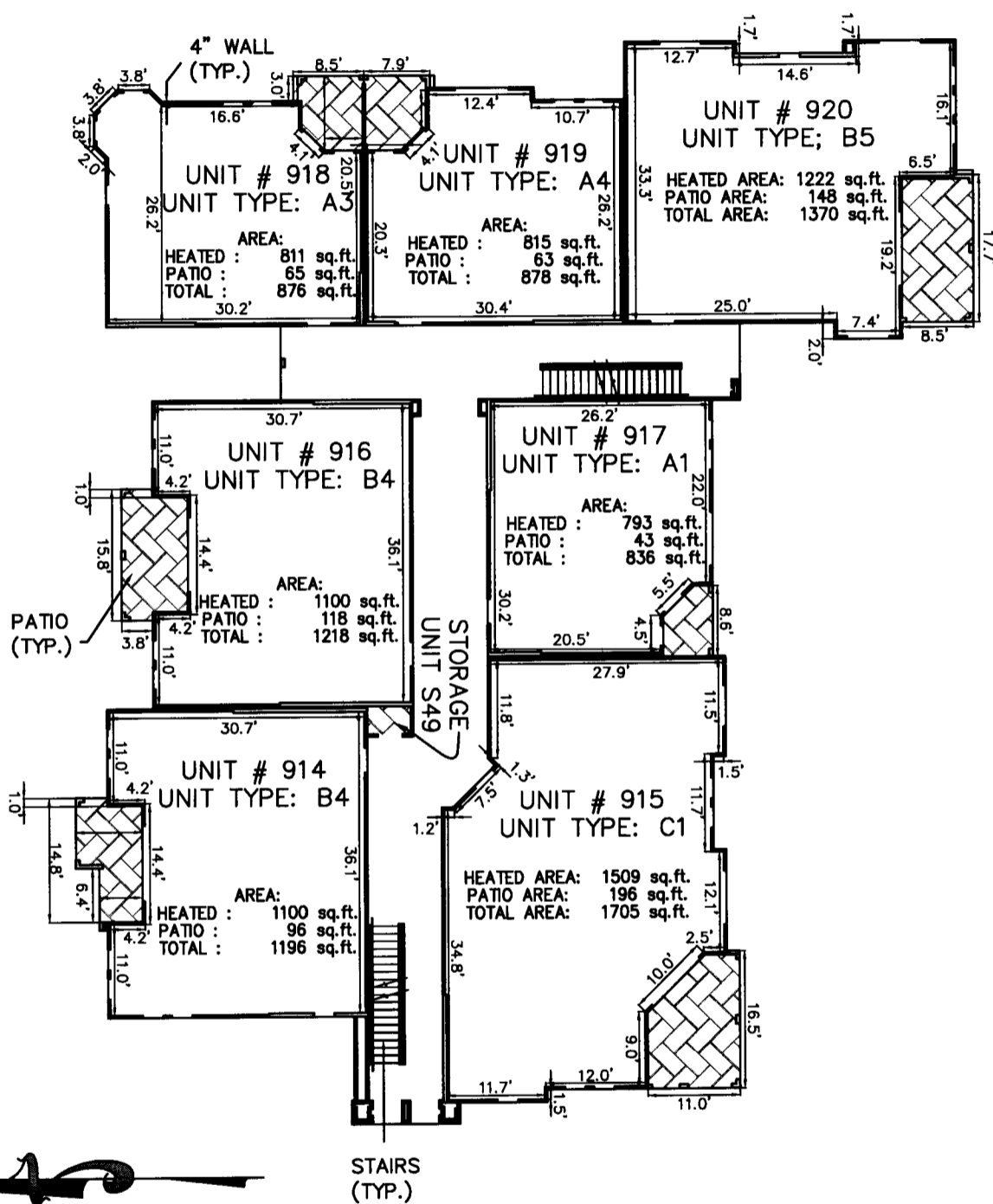

GRAPHIC SCALE



(IN FEET)
1 INCH = 20 FEET



LIMITED COMMON ELEMENT

MILLER LEGG

South Florida Office: 1800 North Douglas Road · Suite 200
Pembroke Pines, Florida · 33024-3200
954-436-7000 · Fax: 954-436-8664
www.millerlegg.com

Certificate of Authorization L.B. 6680

THIS SKETCH DOES NOT REPRESENT A BOUNDARY SURVEY

EXHIBIT

PROJECT NO.
05-00436

FILE NO.
11-1C-280

GARDENS OF BRIDGEHAMPTON, A CONDOMINIUM

BUILDING #10 FIRST FLOOR

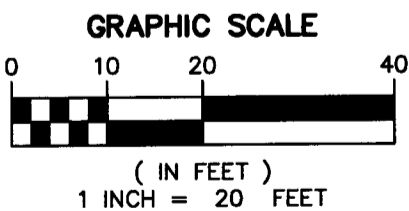
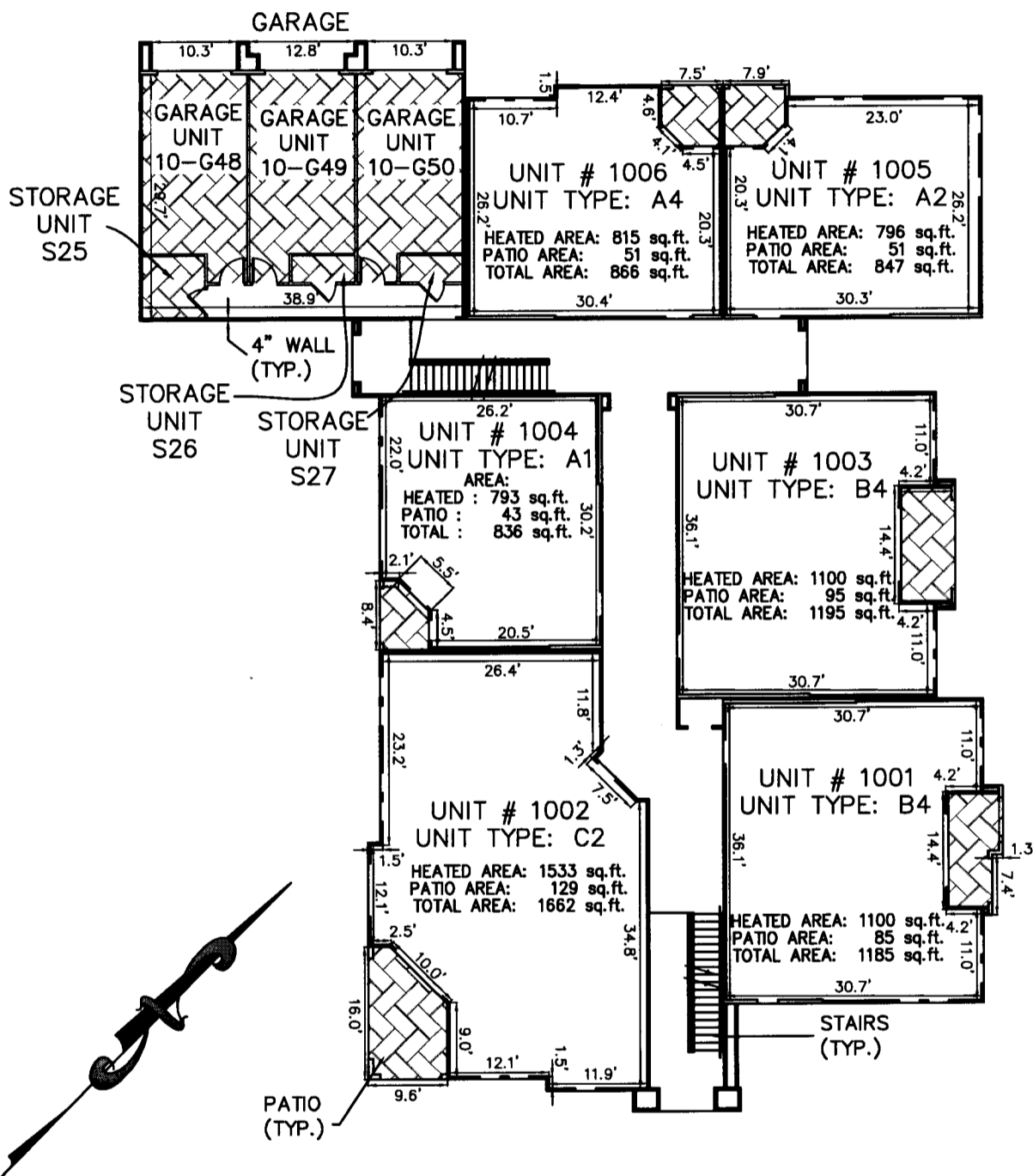

 LIMITED COMMON ELEMENT

MILLER LEGG

South Florida Office: 1800 North Douglas Road · Suite 200
Pembroke Pines, Florida · 33024-3200
954-436-7000 · Fax: 954-436-8664
www.millerlegg.com

Certificate of Authorization L.B. 6680

THIS SKETCH DOES NOT REPRESENT A BOUNDARY SURVEY

EXHIBIT

PROJECT NO.
05-00436

FILE NO.
11-1C-280

EXHIBIT A TO THE DECLARATION OF CONDOMINIUM GARDENS OF BRIDGEHAMPTON, A CONDOMINIUM

BUILDING #10 SECOND FLOOR

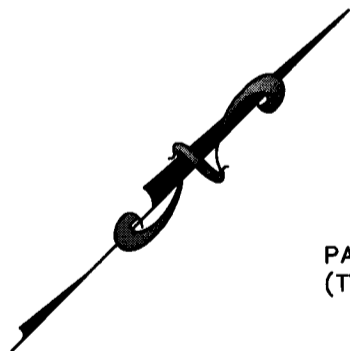
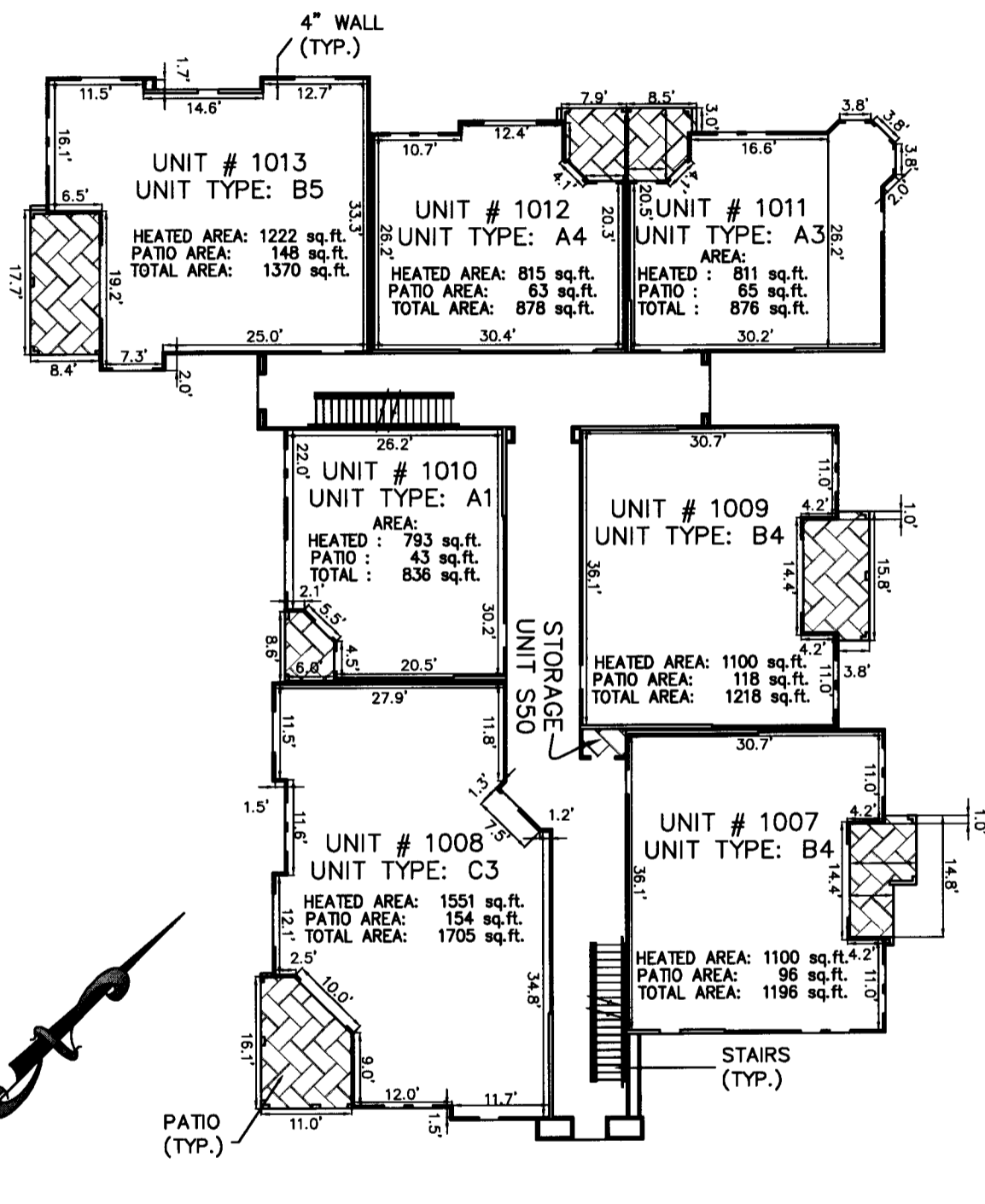

GRAPHIC SCALE



(IN FEET)
1 INCH = 20 FEET



LIMITED COMMON ELEMENT

MILLER LEGG

South Florida Office: 1800 North Douglas Road - Suite 200
Pembroke Pines, Florida - 33024-3200
954-436-7000 · Fax: 954-436-8664
www.millerlegg.com

Certificate of Authorization L.B. 6680

THIS SKETCH DOES NOT REPRESENT A BOUNDARY SURVEY

EXHIBIT

PROJECT NO.
05-00436

FILE NO.
11-1C-280

EXHIBIT A TO THE DECLARATION OF CONDOMINIUM GARDENS OF BRIDGEHAMPTON, A CONDOMINIUM

BUILDING #10

THIRD FLOOR

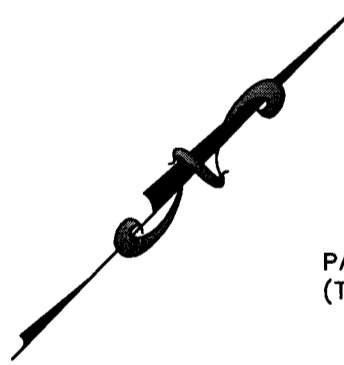
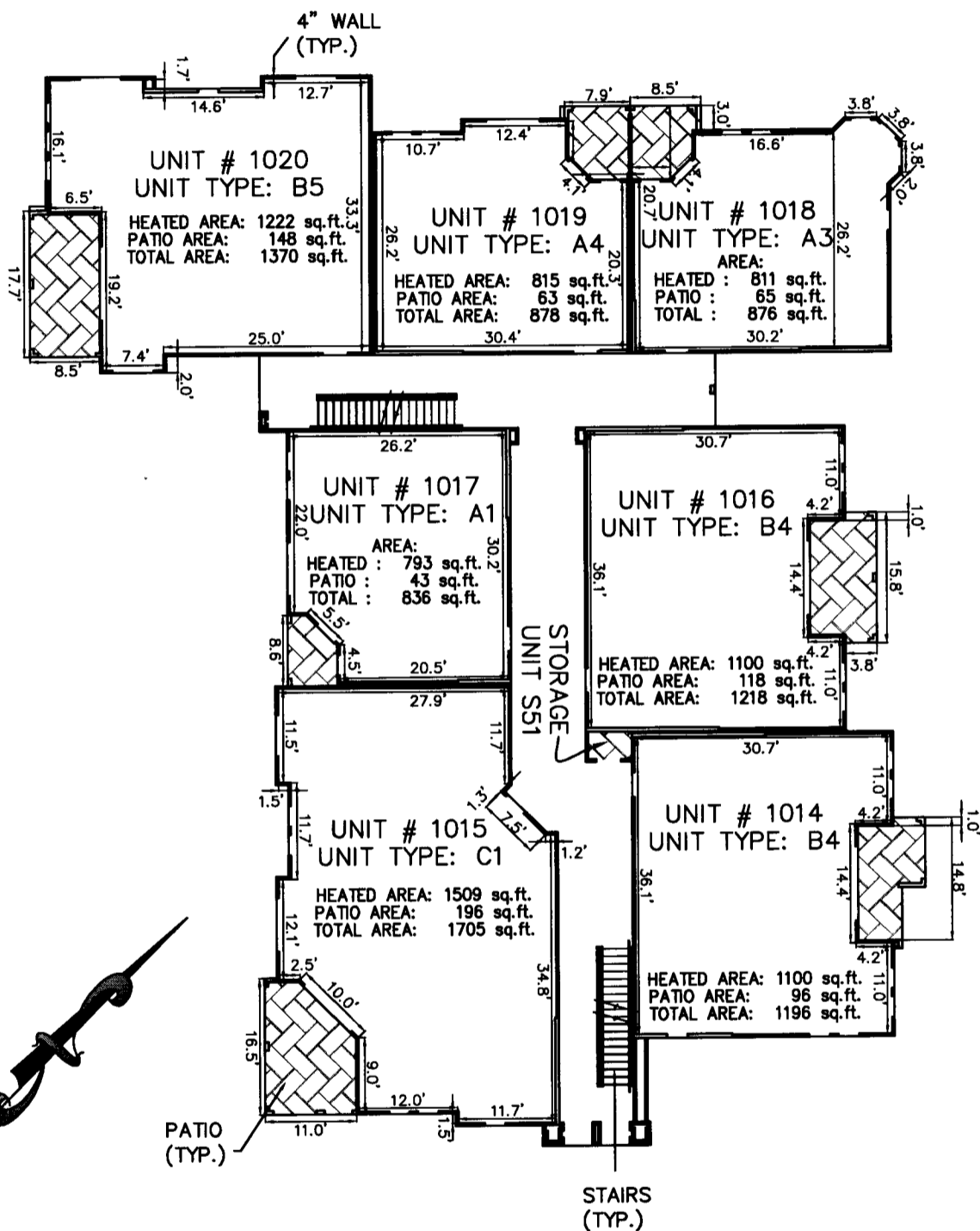

GRAPHIC SCALE



(IN FEET)
1 INCH = 20 FEET



LIMITED COMMON ELEMENT

MILLER LEGG

South Florida Office: 1800 North Douglas Road · Suite 200
Pembroke Pines, Florida · 33024-3200
954-436-7000 · Fax: 954-436-8664
www.millerlegg.com

Certificate of Authorization L.B. 6680

THIS SKETCH DOES NOT REPRESENT A BOUNDARY SURVEY

EXHIBIT

PROJECT NO.
05-00436

FILE NO.
11-1C-280

EXHIBIT A TO THE DECLARATION OF CONDOMINIUM GARDENS OF BRIDGEHAMPTON, A CONDOMINIUM

BUILDING #11 FIRST FLOOR

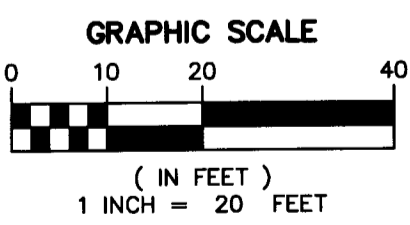
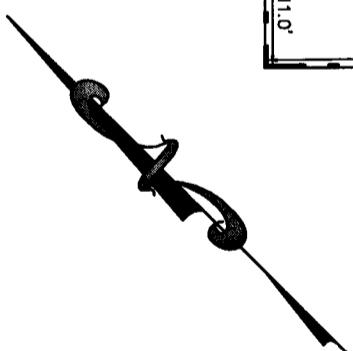
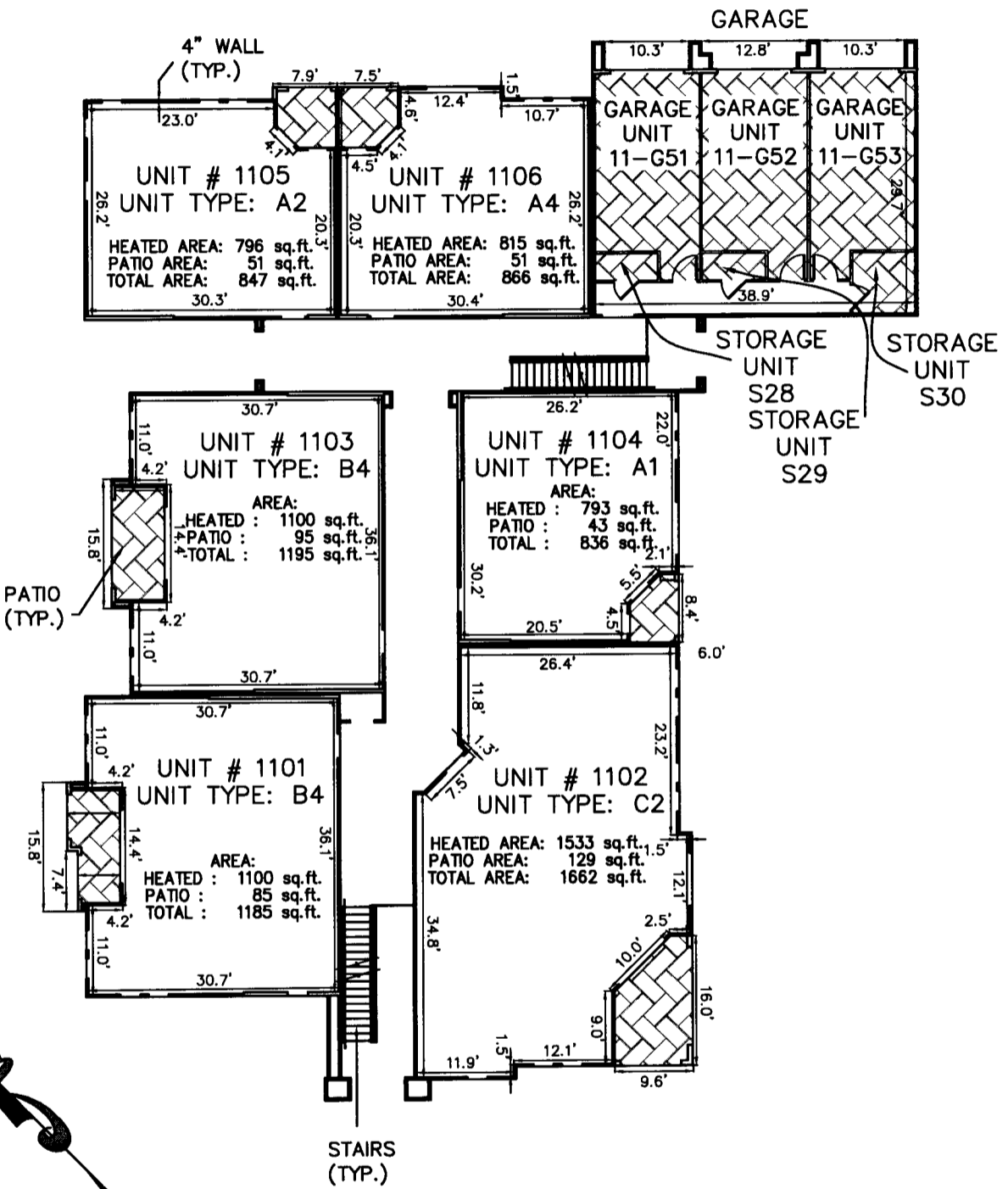

LIMITED COMMON ELEMENT

MILLER LEGG

South Florida Office: 1800 North Douglas Road · Suite 200
Pembroke Pines, Florida · 33024-3200
954-436-7000 · Fax: 954-436-8664
www.millerlegg.com

Certificate of Authorization L.B. 6680

THIS SKETCH DOES NOT REPRESENT A BOUNDARY SURVEY

EXHIBIT

PROJECT NO.
05-00436

FILE NO.
11-1C-280

EXHIBIT A TO THE DECLARATION OF CONDOMINIUM GARDENS OF BRIDGEHAMPTON, A CONDOMINIUM

BUILDING #11 SECOND FLOOR

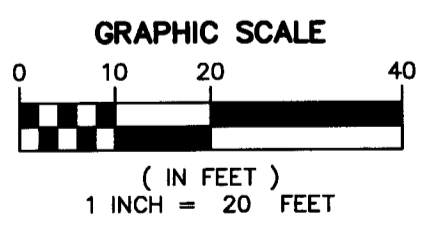
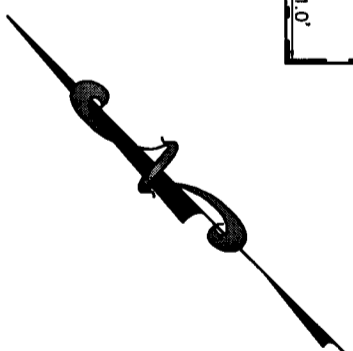
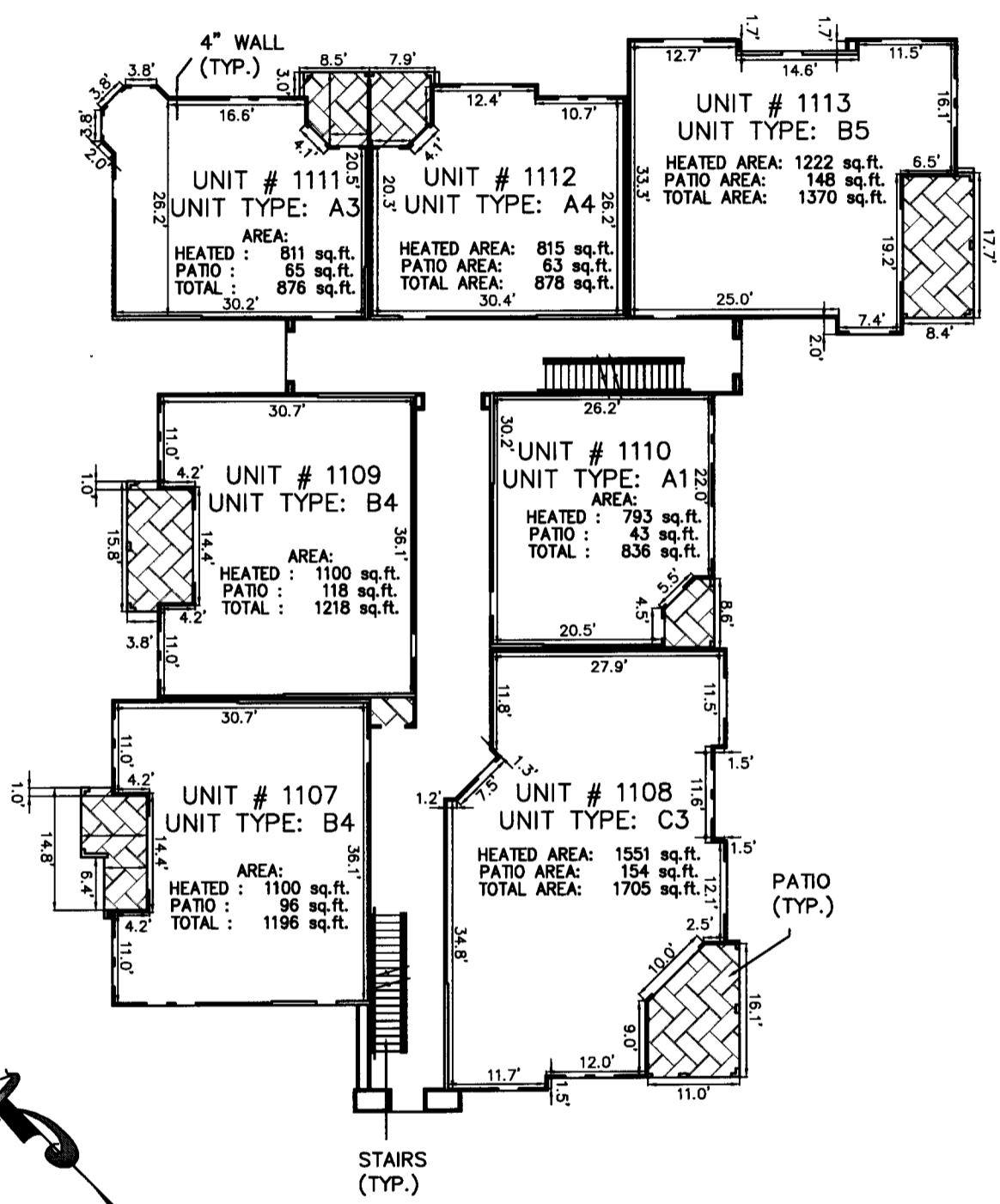

LIMITED COMMON ELEMENT

MILLER LEGG
South Florida Office: 1800 North Douglas Road - Suite 200
Pembroke Pines, Florida - 33024-3200
954-436-7000 · Fax: 954-436-6664
www.millerlegg.com

Certificate of Authorization L.B. 6680

THIS SKETCH DOES NOT REPRESENT A BOUNDARY SURVEY

EXHIBIT

PROJECT NO.
05-00436

FILE NO.
11-1C-280

EXHIBIT A TO THE DECLARATION OF CONDOMINIUM GARDENS OF BRIDGEHAMPTON, A CONDOMINIUM

BUILDING #11 THIRD FLOOR

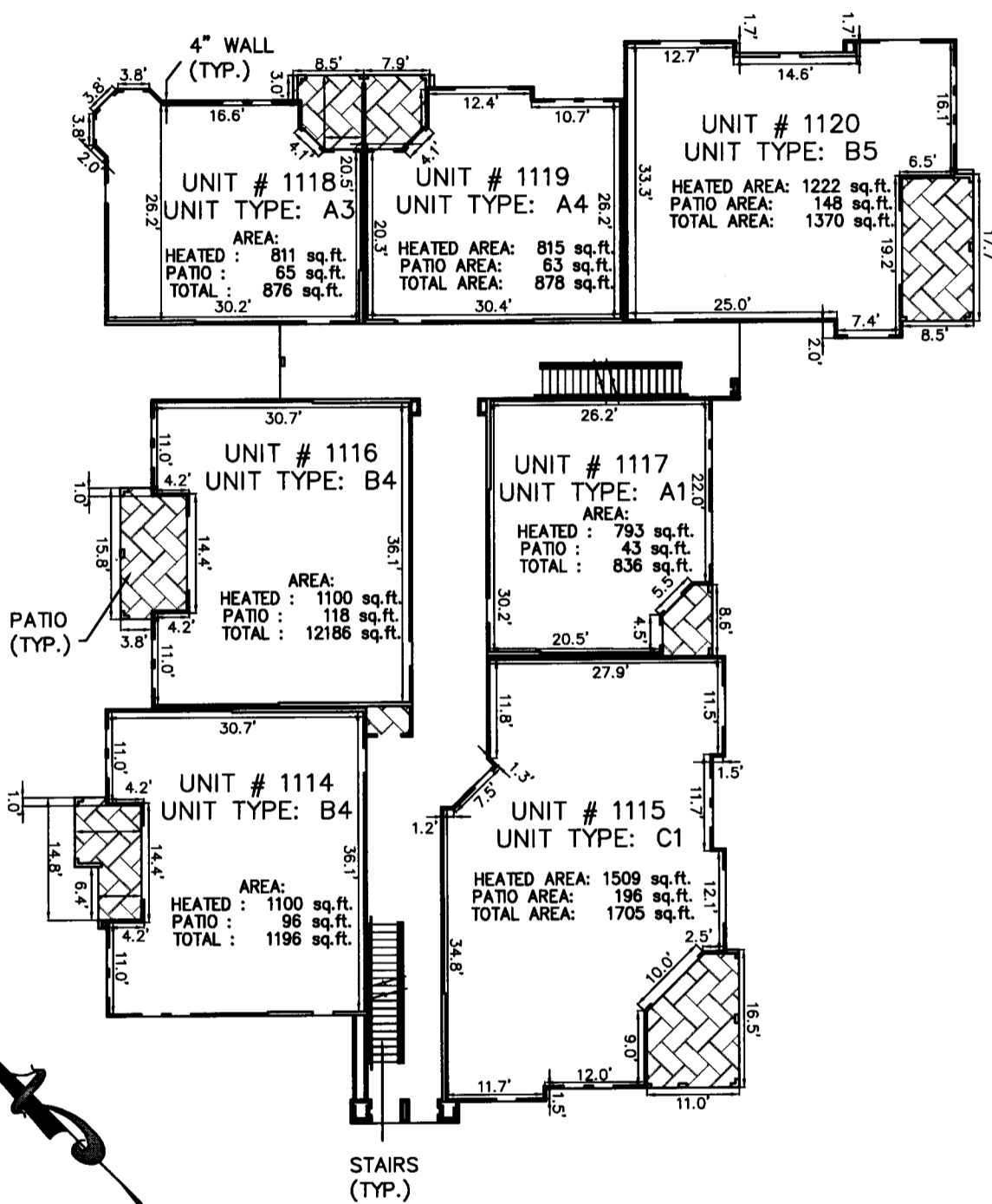

GRAPHIC SCALE



(IN FEET)
1 INCH = 20 FEET



LIMITED COMMON ELEMENT

MILLER LEGG

South Florida Office: 1800 North Douglas Road · Suite 200
Pembroke Pines, Florida · 33024-3200
954-436-7000 · Fax: 954-436-8684
www.millerlegg.com

Certificate of Authorization L.B. 6680

THIS SKETCH DOES NOT REPRESENT A BOUNDARY SURVEY

EXHIBIT

PROJECT NO.

05-00436

FILE NO.

11-1C-280

EXHIBIT A TO THE DECLARATION OF CONDOMINIUM GARDENS OF BRIDGEHAMPTON, A CONDOMINIUM

BUILDING #12 FIRST FLOOR

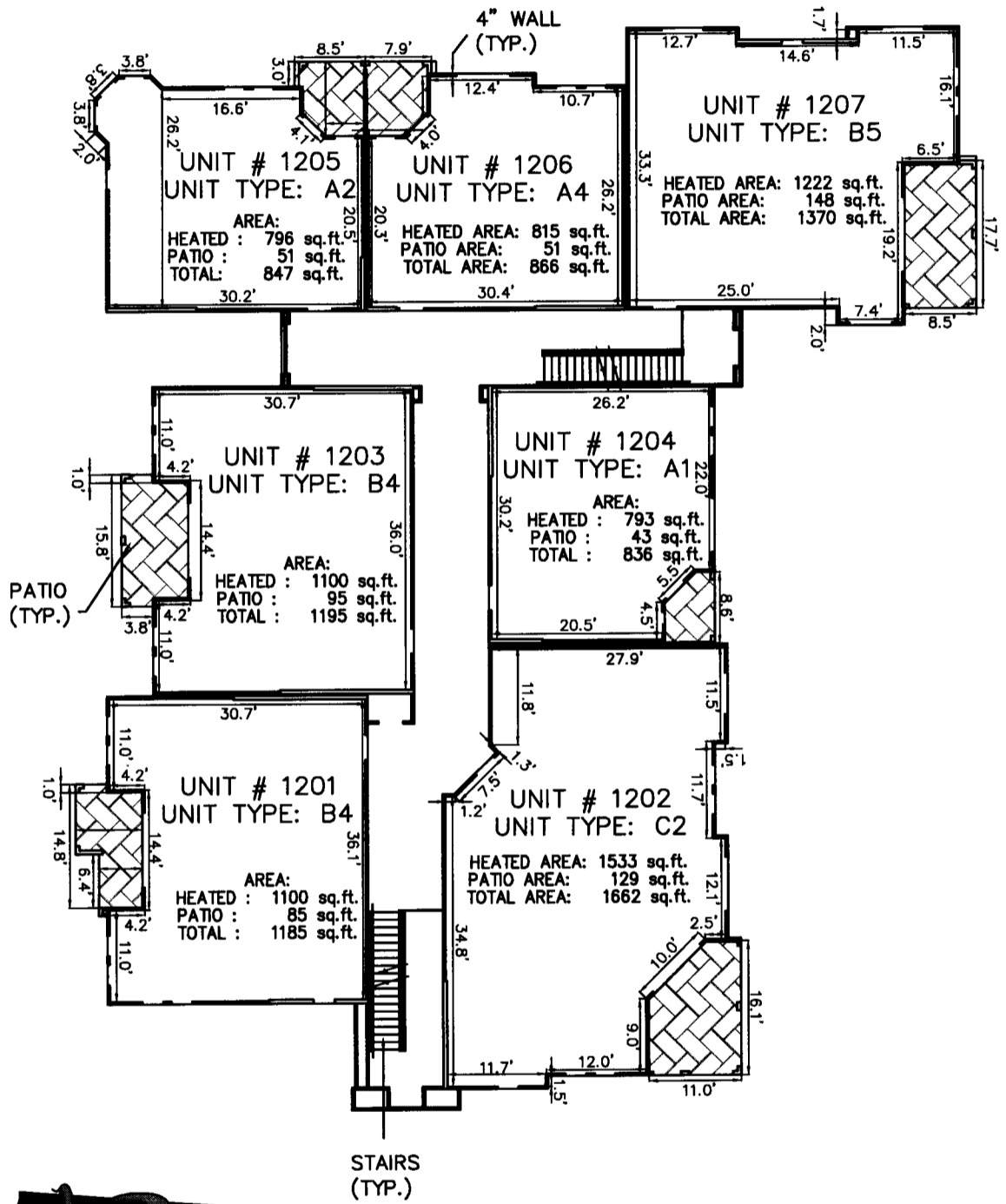

GRAPHIC SCALE



(IN FEET)
1 INCH = 20 FEET



LIMITED COMMON ELEMENT

MILLER LEGG

South Florida Office: 1800 North Douglas Road - Suite 200
Pembroke Pines, Florida : 33024-3200
954-436-7000 - Fax: 954-436-8664
www.millerlegg.com

Certificate of Authorization L.B. 6680

THIS SKETCH DOES NOT REPRESENT A BOUNDARY SURVEY

EXHIBIT

PROJECT NO.
05-00436

FILE NO.
11-1C-280

EXHIBIT A TO THE DECLARATION OF CONDOMINIUM GARDENS OF BRIDGEHAMPTON, A CONDOMINIUM

BUILDING #12 SECOND FLOOR

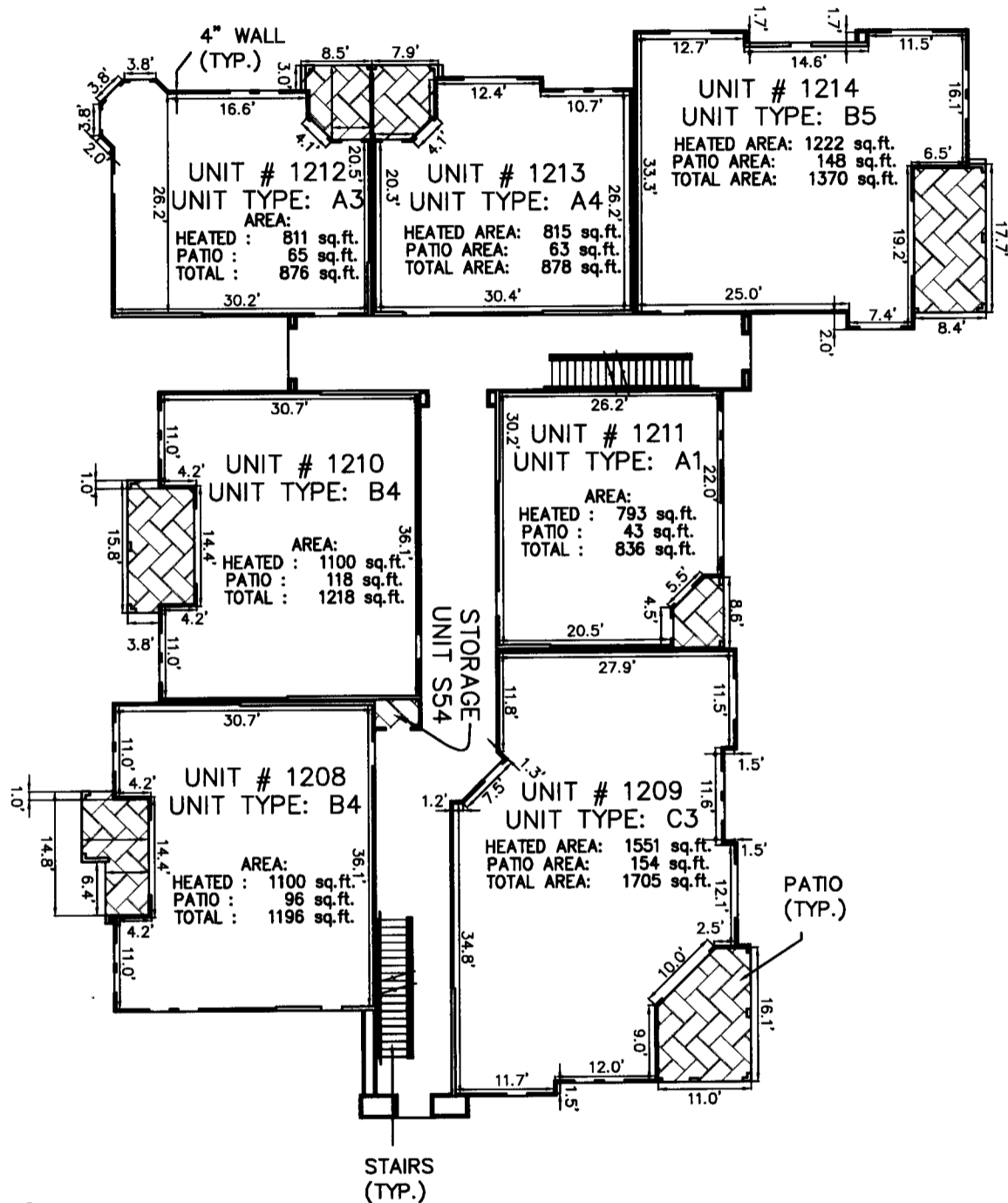

GRAPHIC SCALE



(IN FEET)
1 INCH = 20 FEET



LIMITED COMMON ELEMENT



South Florida Office: 1800 North Douglas Road · Suite 200
Pembroke Pines, Florida · 33024-3200
954-436-7000 · Fax: 954-436-8864
www.millerlegg.com

Certificate of Authorization L.B. 6680

THIS SKETCH DOES NOT REPRESENT A BOUNDARY SURVEY

EXHIBIT

PROJECT NO.
05-00436

FILE NO.
11-1C-280

EXHIBIT A TO THE DECLARATION OF CONDOMINIUM GARDENS OF BRIDGEHAMPTON, A CONDOMINIUM

BUILDING #12

THIRD FLOOR

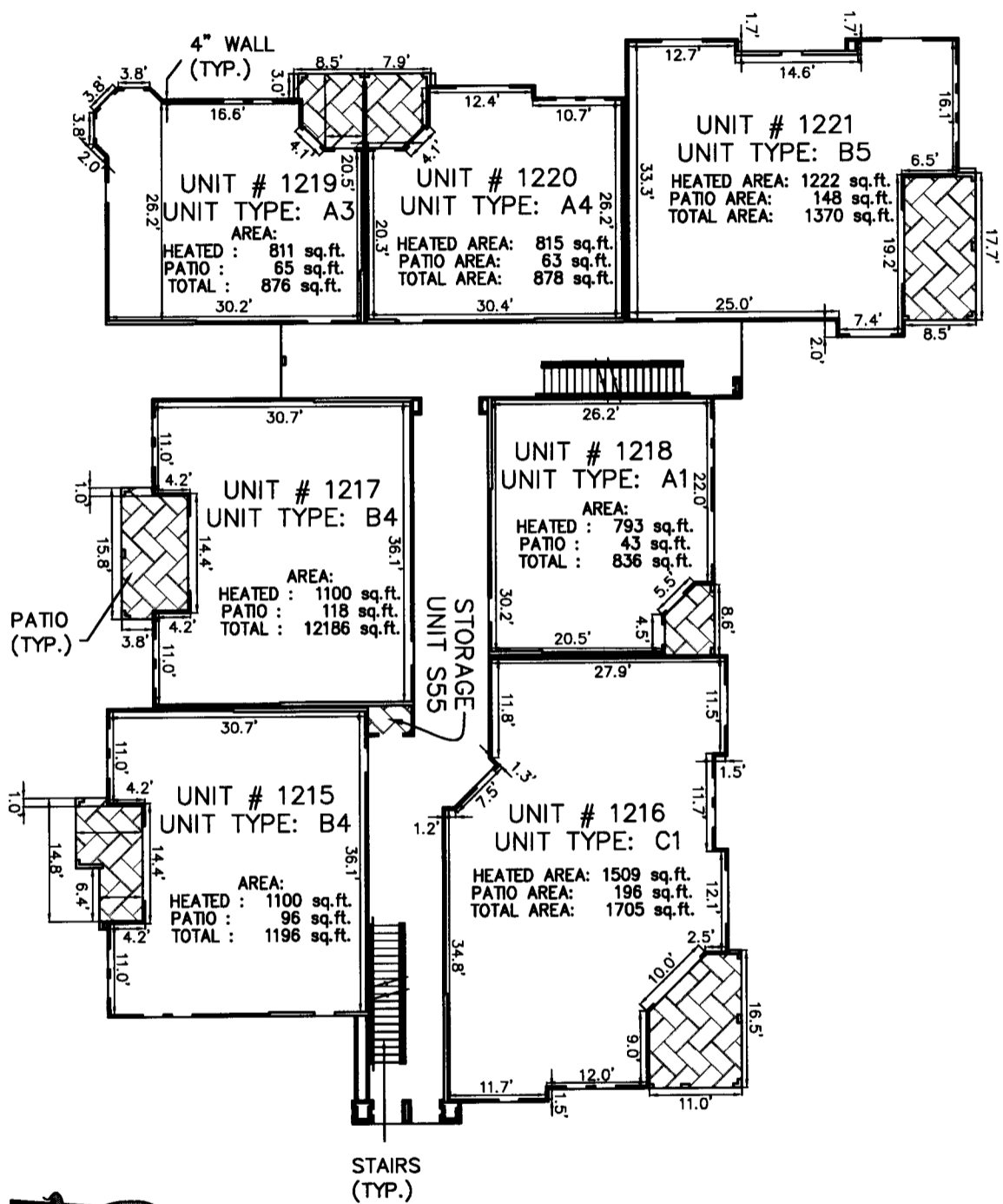

GRAPHIC SCALE



(IN FEET)
1 INCH = 20 FEET



LIMITED COMMON ELEMENT

MILLER LEGG
 South Florida Office: 1800 North Douglas Road · Suite 200
 Pembroke Pines, Florida · 33024-3200
 954-436-7000 · Fax: 954-436-8684
 www.millerlegg.com

Certificate of Authorization L.B. 6680

THIS SKETCH DOES NOT REPRESENT A BOUNDARY SURVEY

EXHIBIT

PROJECT NO.
05-00436

FILE NO.
11-1C-280

EXHIBIT A TO THE DECLARATION OF CONDOMINIUM GARDENS OF BRIDGEHAMPTON, A CONDOMINIUM

BUILDING #13 FIRST FLOOR

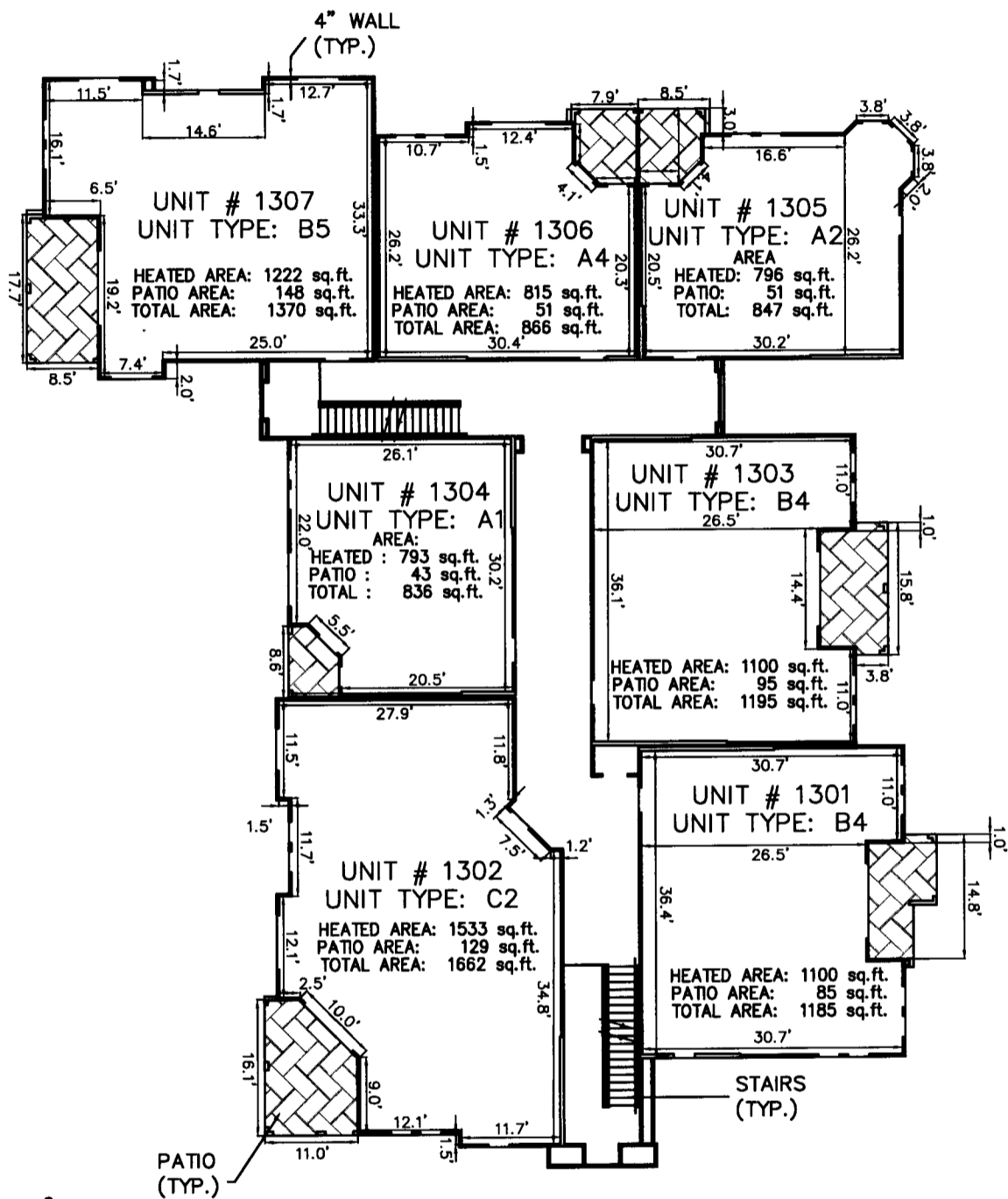

GRAPHIC SCALE



(IN FEET)
1 INCH = 20 FEET



LIMITED COMMON ELEMENT

MILLER LEGG

South Florida Office: 1800 North Douglas Road · Suite 200
Pembroke Pines, Florida · 33024-3200
954-436-7000 · Fax: 954-436-8664
www.millerlegg.com

Certificate of Authorization L.B. 6680

THIS SKETCH DOES NOT REPRESENT A BOUNDARY SURVEY

EXHIBIT

PROJECT NO.
05-00436

FILE NO.
11-1C-280

EXHIBIT A TO THE DECLARATION OF CONDOMINIUM GARDENS OF BRIDGEHAMPTON, A CONDOMINIUM

BUILDING #13 SECOND FLOOR

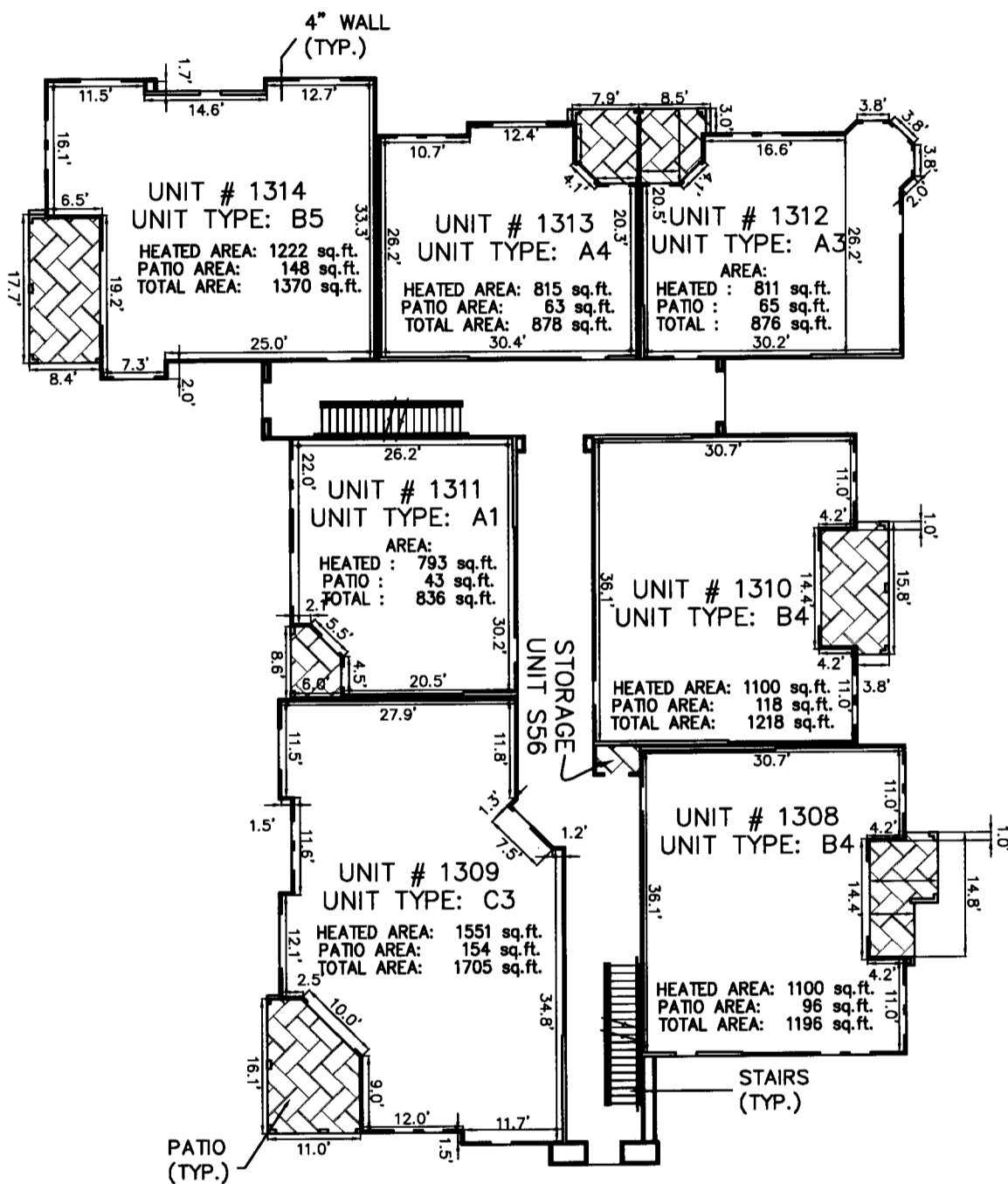

GRAPHIC SCALE



(IN FEET)
1 INCH = 20 FEET



LIMITED COMMON ELEMENT

MILLER LEGG

South Florida Office: 1800 North Douglas Road · Suite 200
Pembroke Pines, Florida · 33024-3200
954-436-7000 · Fax: 954-436-8664
www.millerlegg.com

Certificate of Authorization L.B. 6660

THIS SKETCH DOES NOT REPRESENT A BOUNDARY SURVEY

EXHIBIT

PROJECT NO.

05-00436

FILE NO.

11-1C-280

EXHIBIT A TO THE DECLARATION OF CONDOMINIUM GARDENS OF BRIDGEHAMPTON, A CONDOMINIUM

BUILDING #13 THIRD FLOOR

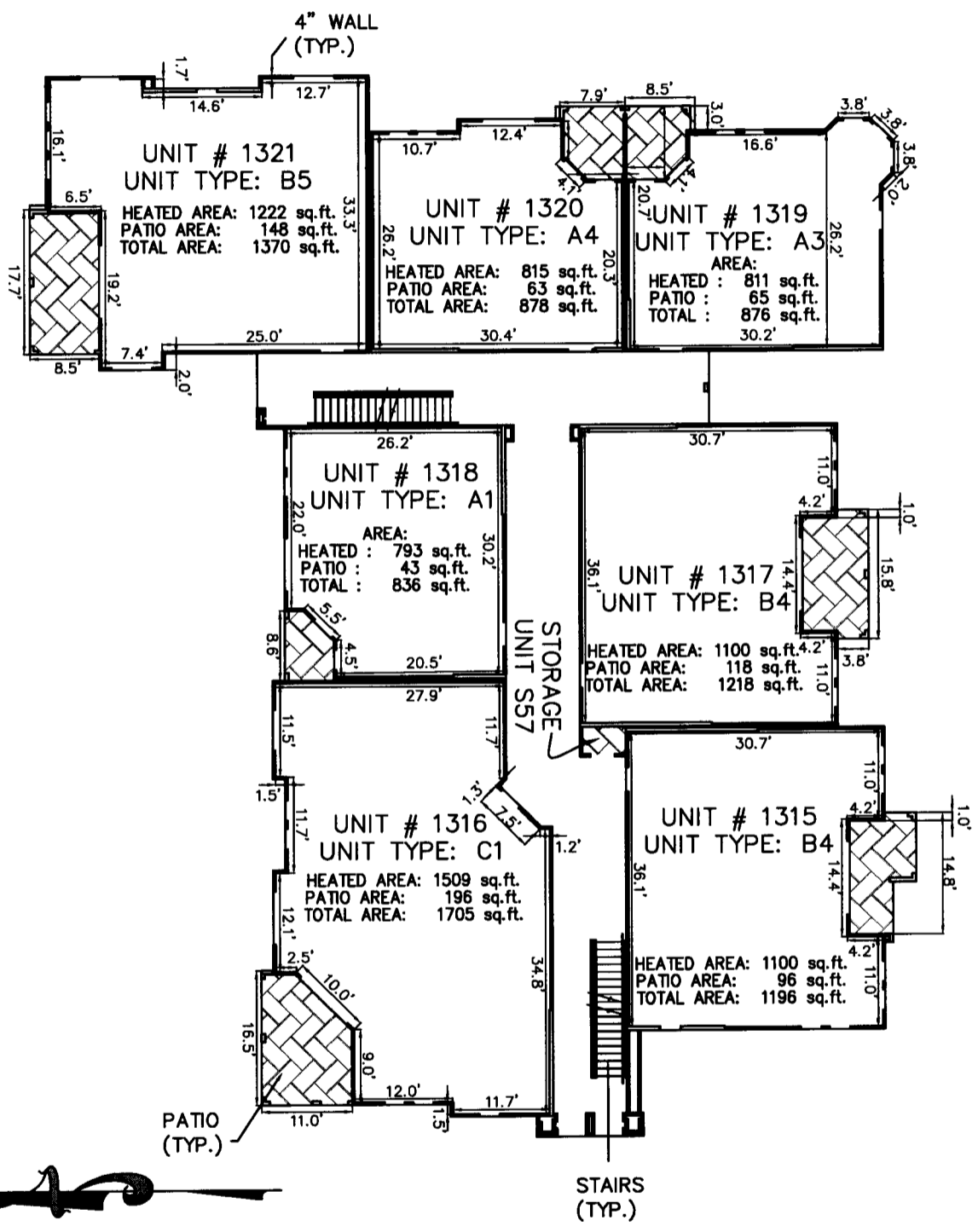

GRAPHIC SCALE

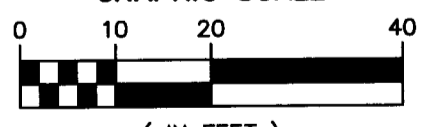

(IN FEET)
1 INCH = 20 FEET

LIMITED COMMON ELEMENT

MILLER LEGG
South Florida Office: 1800 North Douglas Road - Suite 200
Pembroke Pines, Florida - 33024-3200
954-436-7000 - Fax: 954-436-8664
www.millerlegg.com

Certificate of Authorization L.B. 6680

THIS SKETCH DOES NOT REPRESENT A BOUNDARY SURVEY

EXHIBIT

PROJECT NO.
05-00436

FILE NO.
11-1C-280

EXHIBIT A TO THE DECLARATION OF CONDOMINIUM GARDENS OF BRIDGEHAMPTON, A CONDOMINIUM

BUILDING #14

FIRST FLOOR

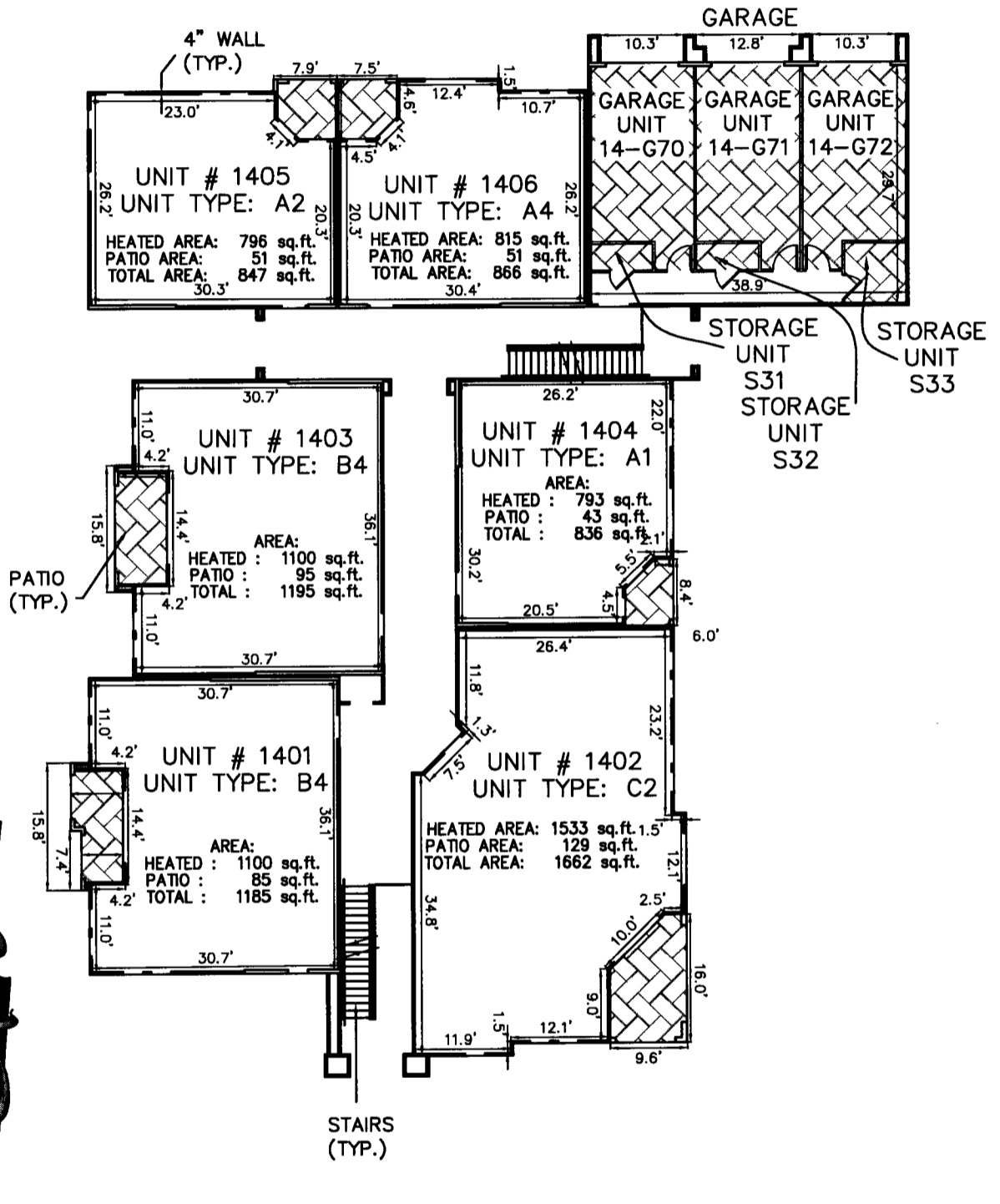

GRAPHIC SCALE

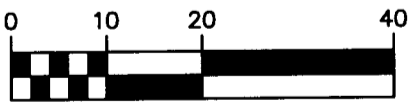

(IN FEET)
1 INCH = 20 FEET



LIMITED COMMON ELEMENT

MILLER LEGG

South Florida Office: 1800 North Douglas Road · Suite 200
Pembroke Pines, Florida · 33024-3200
954-436-7000 · Fax: 954-436-8664
www.millerlegg.com

Certificate of Authorization L.B. 6680

THIS SKETCH DOES NOT REPRESENT A BOUNDARY SURVEY

EXHIBIT

PROJECT NO.
05-00436

FILE NO.
11-1C-280

EXHIBIT A TO THE DECLARATION OF CONDOMINIUM GARDENS OF BRIDGEHAMPTON, A CONDOMINIUM

BUILDING #14 SECOND FLOOR

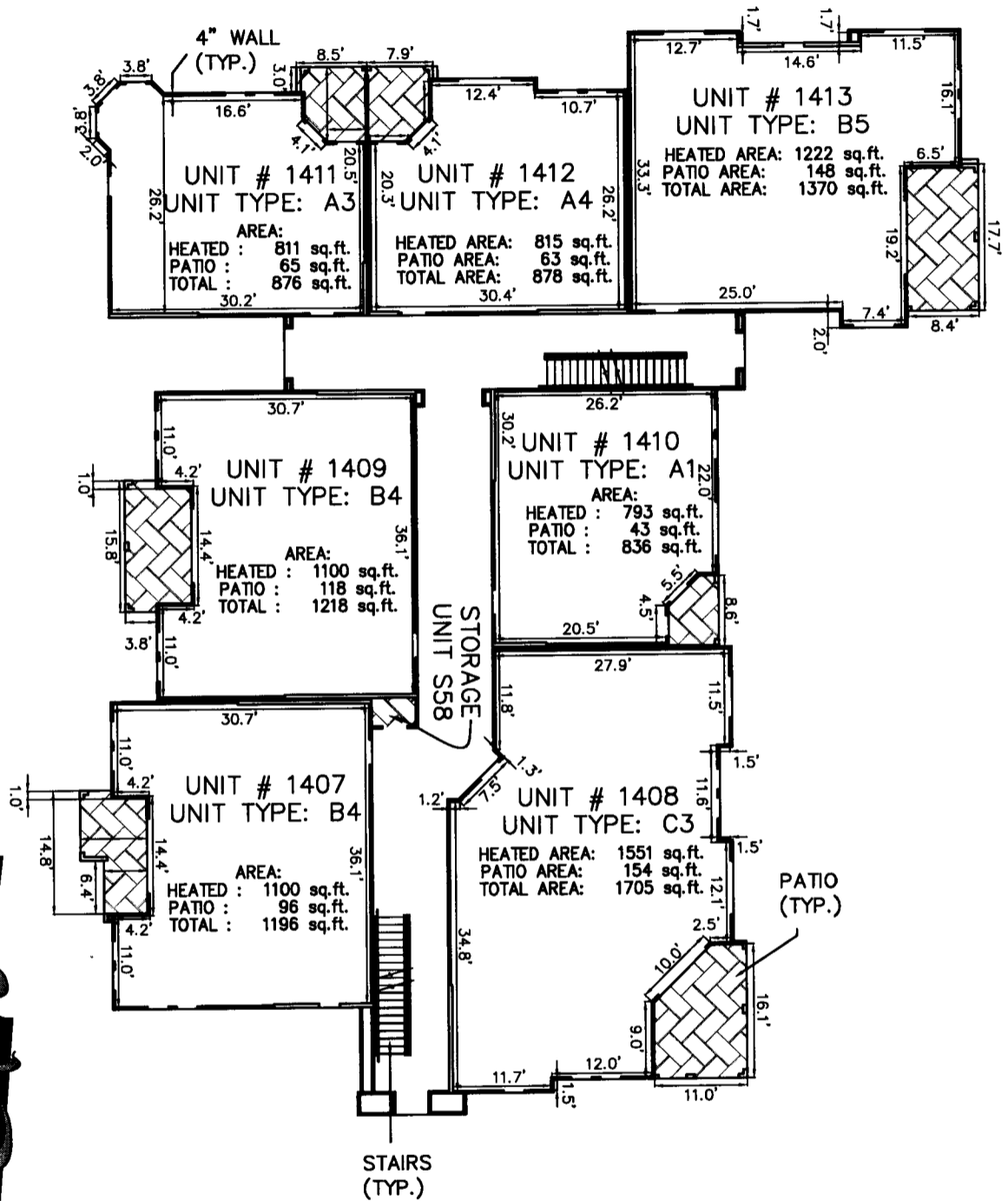

GRAPHIC SCALE

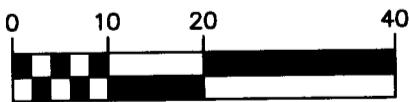

(IN FEET)
1 INCH = 20 FEET



LIMITED COMMON ELEMENT

MILLER LEGG

South Florida Office: 1800 North Douglas Road · Suite 200
Pembroke Pines, Florida · 33024-3200
954-436-7000 · Fax: 954-436-8664
www.millerlegg.com

Certificate of Authorization L.B. 6880

THIS SKETCH DOES NOT REPRESENT A BOUNDARY SURVEY

EXHIBIT

PROJECT NO.

05-00436

FILE NO.

11-1C-280

EXHIBIT A TO THE DECLARATION OF CONDOMINIUM GARDENS OF BRIDGEHAMPTON, A CONDOMINIUM

BUILDING #14 THIRD FLOOR

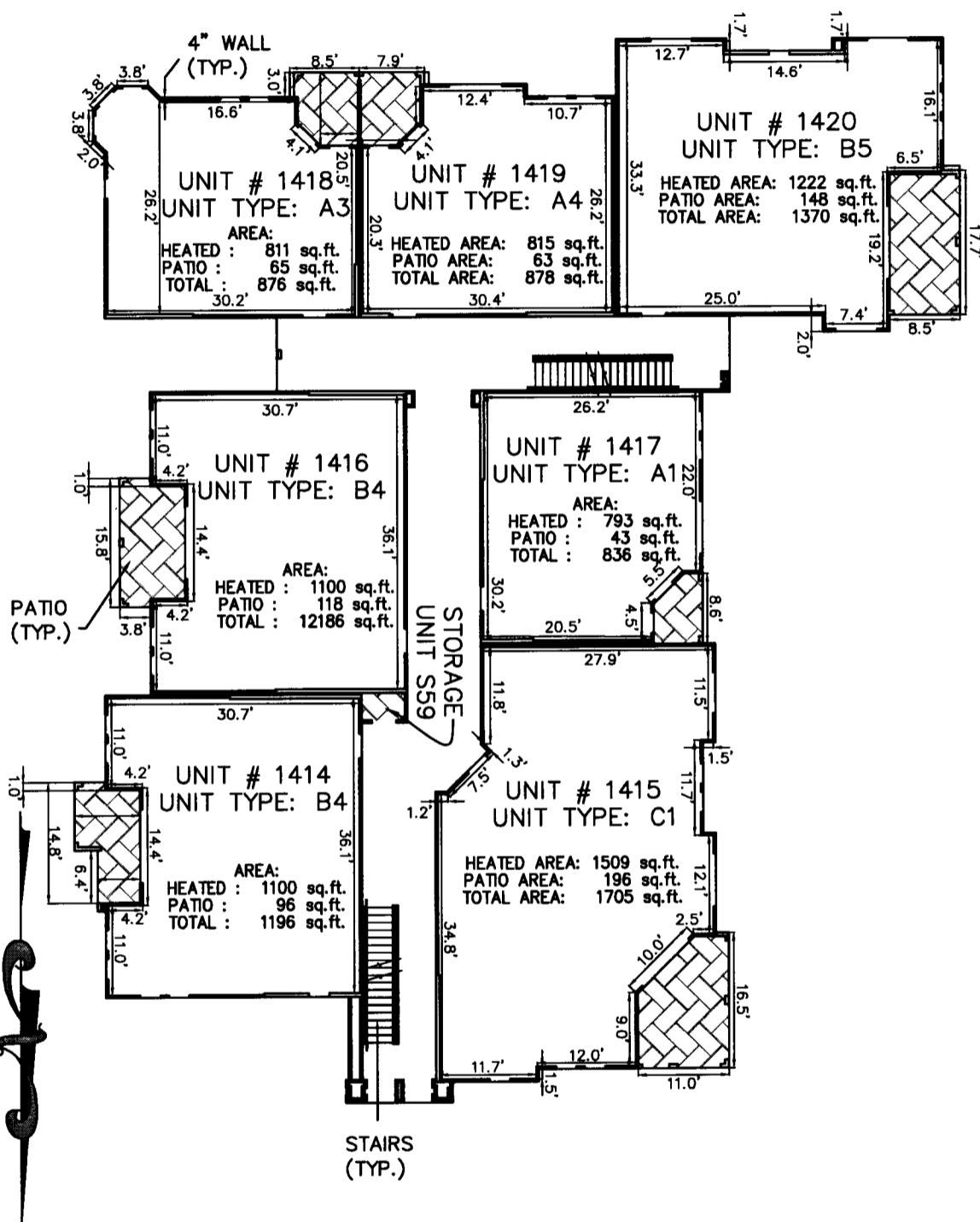

GRAPHIC SCALE



(IN FEET)
1 INCH = 20 FEET



LIMITED COMMON ELEMENT

MILLER LEGG

South Florida Office: 1800 North Douglas Road - Suite 200
Pembroke Pines, Florida - 33024-3200
954-436-7000 - Fax: 954-436-8664
www.millerlegg.com

Certificate of Authorization L.B. 6680

THIS SKETCH DOES NOT REPRESENT A BOUNDARY SURVEY

EXHIBIT

PROJECT NO.
05-00436

FILE NO.
11-1C-280

EXHIBIT A TO THE DECLARATION OF CONDOMINIUM
GARDENS OF BRIDGEHAMPTON, A CONDOMINIUM

GARAGE

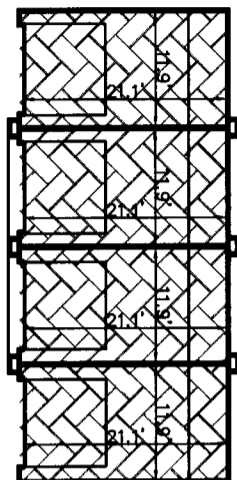

GARAGE TYPE "A"
(A6)

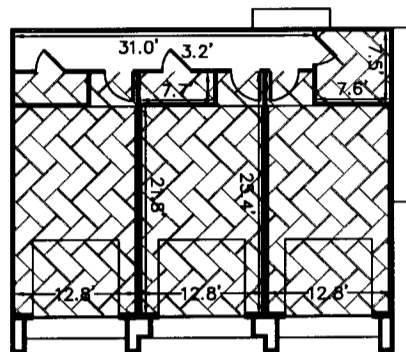

UNIT GARAGE

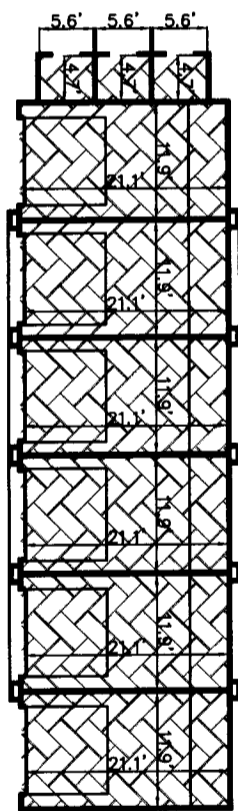

GARAGE TYPE "B"
(B1, B4, B5, B7)

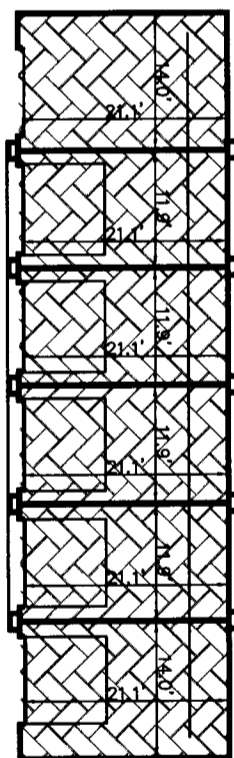

GARAGE TYPE "C"
(C3)

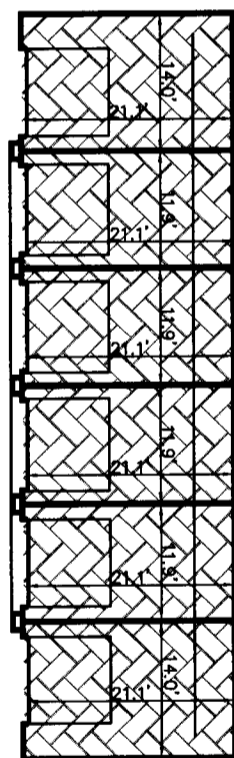

GARAGE TYPE "D"
(D2)



LIMITED COMMON ELEMENT

GRAPHIC SCALE



(IN FEET)
 1 INCH = 20 FEET

MILLER LEGG

South Florida Office: 1800 North Douglas Road - Suite 200
 Pembroke Pines, Florida - 33024-3200
 954-436-7000 - Fax: 954-436-8664
 www.millerlegg.com

Certificate of Authorization L.B. 6680

THIS SKETCH DOES NOT REPRESENT A BOUNDARY SURVEY

EXHIBIT

PROJECT NO.
05-00436

FILE NO.
11-1C-280

EXHIBIT A TO THE DECLARATION OF CONDOMINIUM GARDENS OF BRIDGEHAMPTON, A CONDOMINIUM

GARAGE

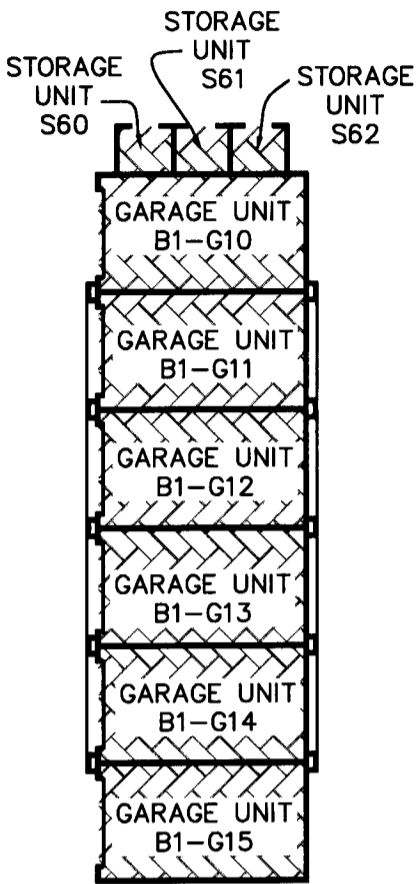

GARAGE B1
TYPE "B"

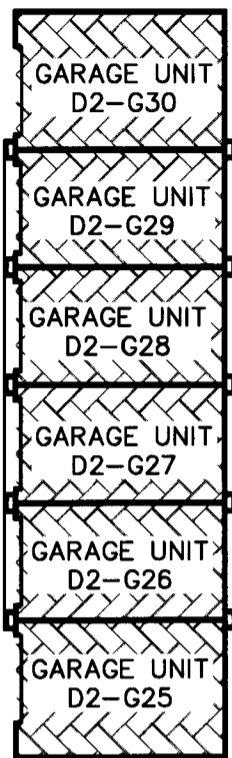

GARAGE D2
TYPE "D"

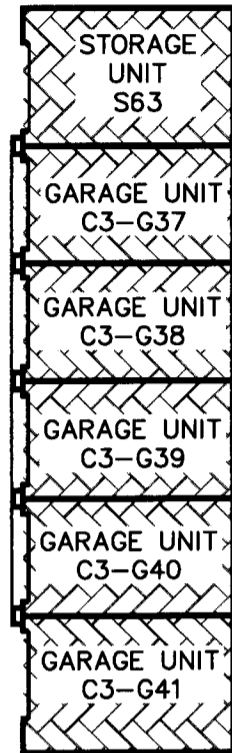

GARAGE C3
TYPE "C"

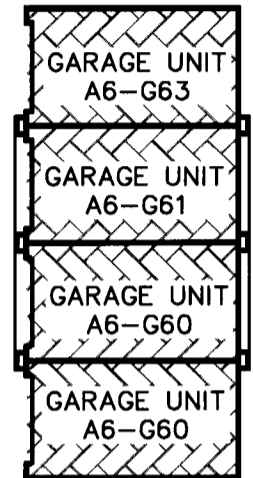

GARAGE A6
TYPE "A"

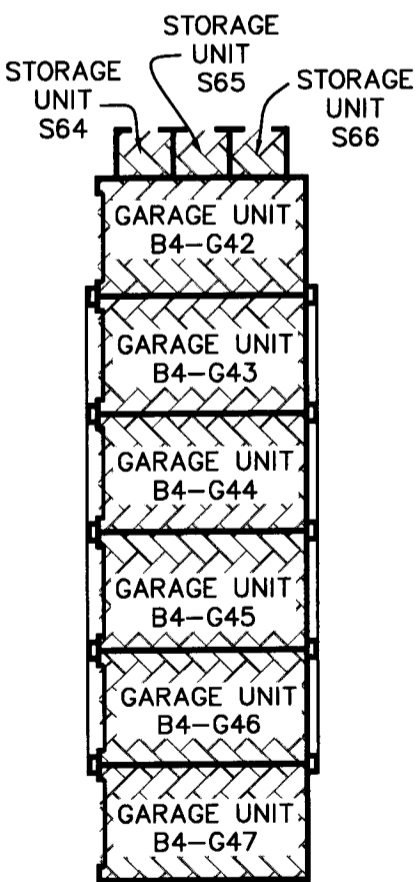

GARAGE B4
TYPE "B"

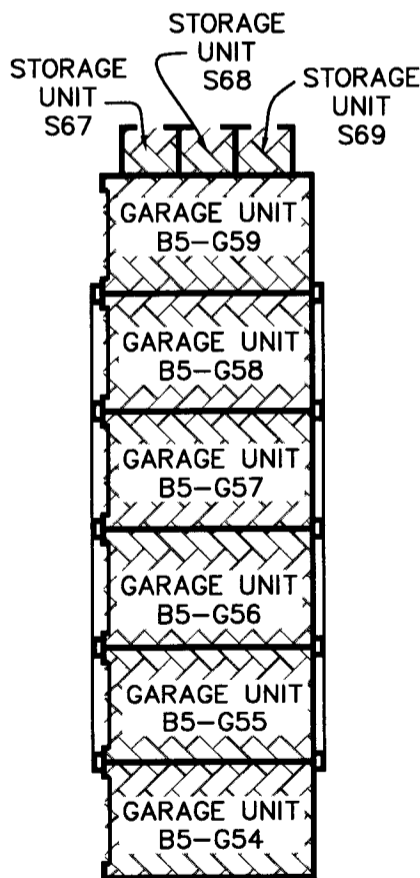

GARAGE B5
TYPE "B"

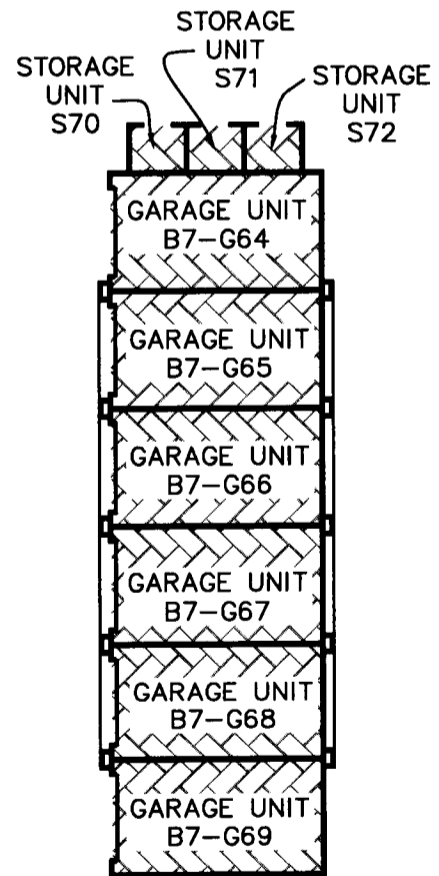

GARAGE B7
TYPE "B"



LIMITED COMMON ELEMENT

GRAPHIC SCALE



(IN FEET)
1 INCH = 20 FEET

MILLER LEGG

South Florida Office: 1800 North Douglas Road · Suite 200
Pembroke Pines, Florida · 33024-3200
954-436-7000 · Fax: 954-436-8664
www.millerlegg.com

Certificate of Authorization L.B. 6680

THIS SKETCH DOES NOT REPRESENT A BOUNDARY SURVEY

EXHIBIT

PROJECT NO.
05-00436

FILE NO.
11-1C-280

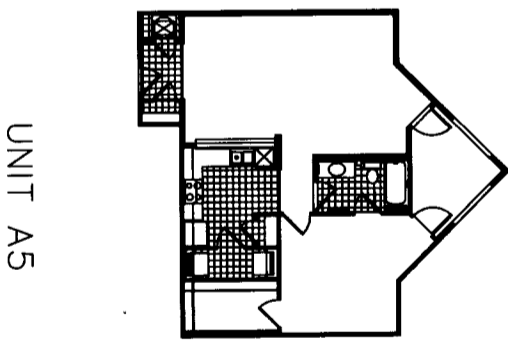
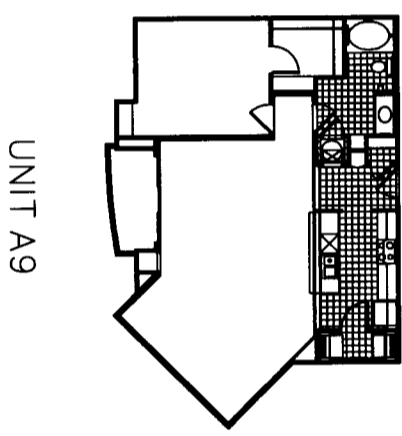
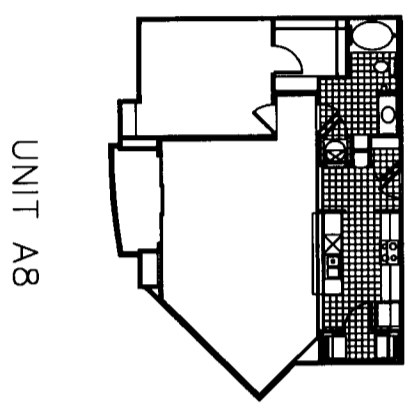
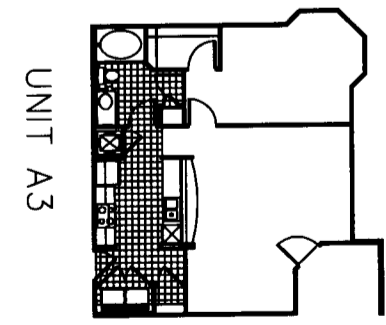
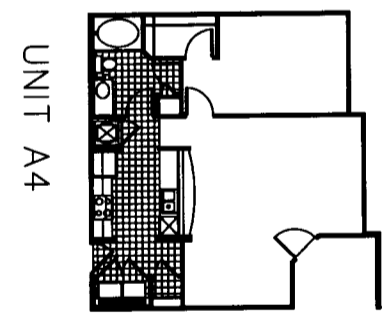
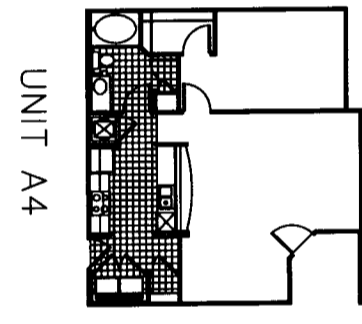
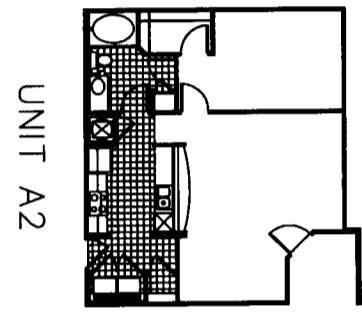
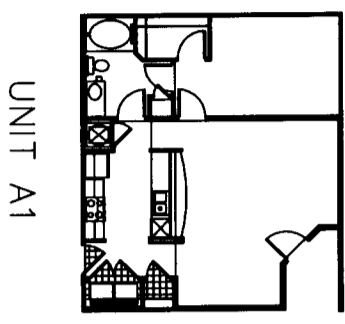
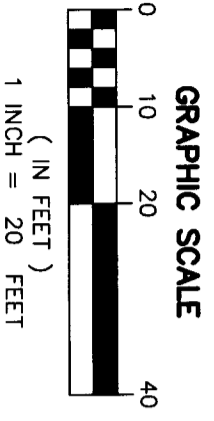

INFORMATION ON THIS SHEET OBTAINED FROM ARCHITECTURAL PLAN RELEASED BY THE HOUSING STUDIO ARCHITECTS AND WAS NOT FIELD VERIFIED.

GARDENS OF BRIDGEHAMPTON,
A CONDOMINIUM

MILLER LEGG
South Florida Office: 1800 North Douglas Road · Suite 200
Pembroke Pines, Florida · 33024-3200
954-436-7000 · Fax: 954-436-8664
www.millerlegg.com

Certificate of Authorization L.B. 6680

THIS SKETCH DOES NOT REPRESENT A BOUNDARY SURVEY

EXHIBIT

PROJECT NO.
05-00436

FILE NO.
11-1C-280

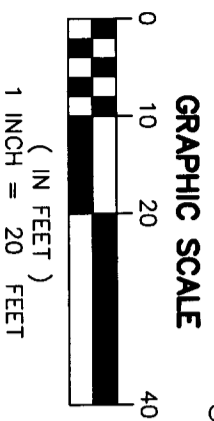

UNIT C2

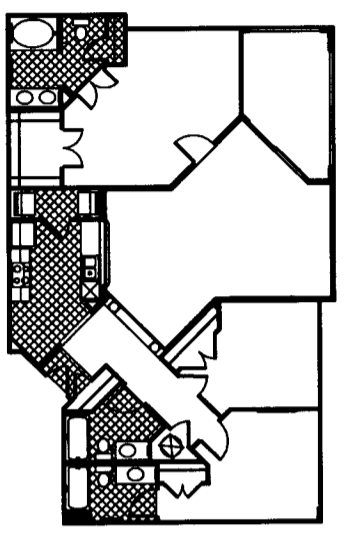

UNIT C3

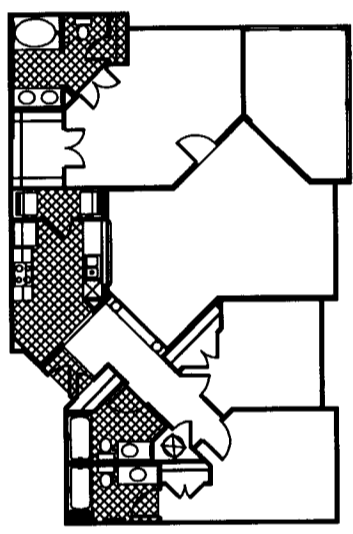

UNIT C1

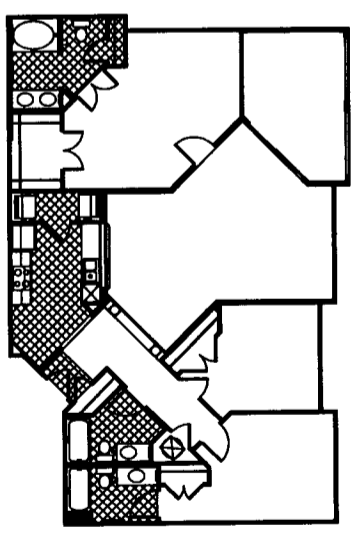

UNIT B3

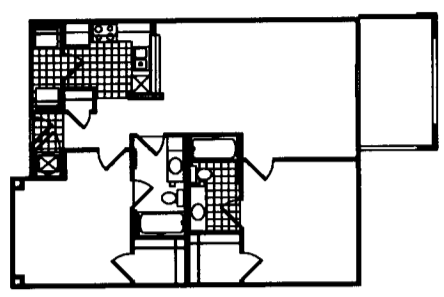

UNIT B3

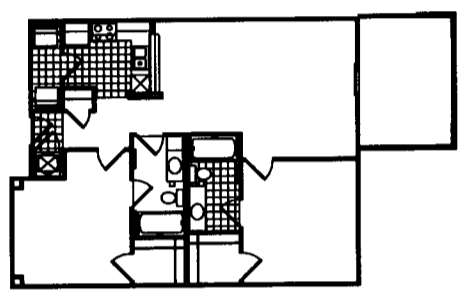

UNIT B3

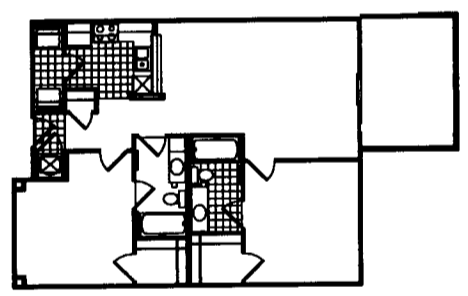

UNIT B3

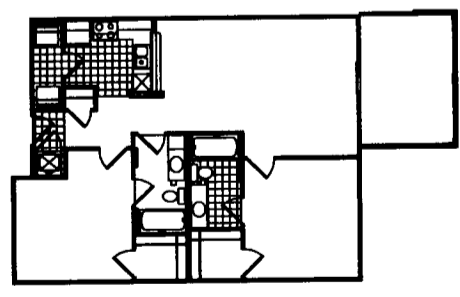

INFORMATION ON THIS SHEET OBTAINED FROM
ARCHITECTURAL PLAN RELEASED BY THE HOUSING STUDIO
ARCHITECTS AND WAS NOT FIELD VERIFIED.

GARDENS OF BRIDGEHAMPTON,
A CONDOMINIUM.

MILLER LEGG
South Florida Office: 1800 North Douglas Road · Suite 200
Pembroke Pines, Florida · 33024-3200
954-436-7000 · Fax: 954-436-8664
www.millerlegg.com

Certificate of Authorization L.B. 6680

THIS SKETCH DOES NOT REPRESENT A BOUNDARY SURVEY

EXHIBIT

PROJECT NO.
05-00436

FILE NO.
11-1C-280

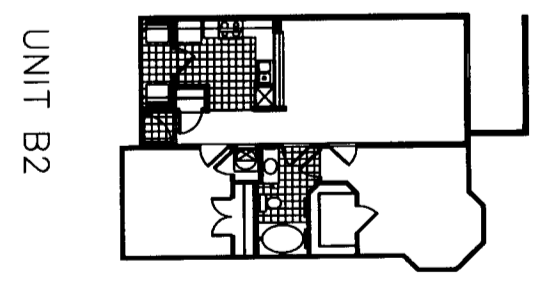
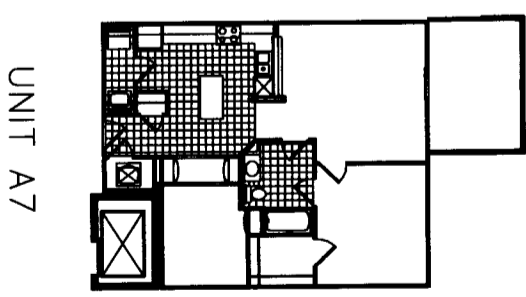
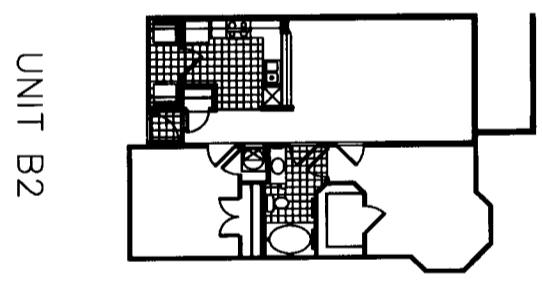
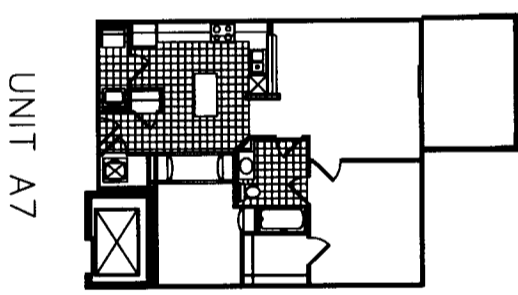
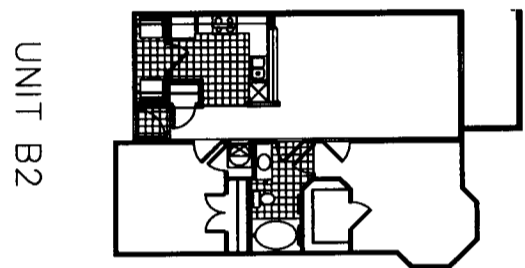
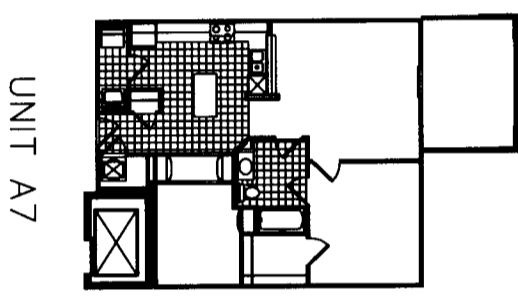
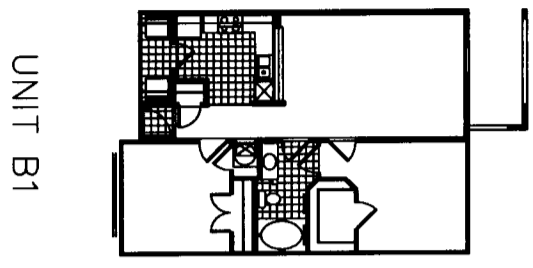
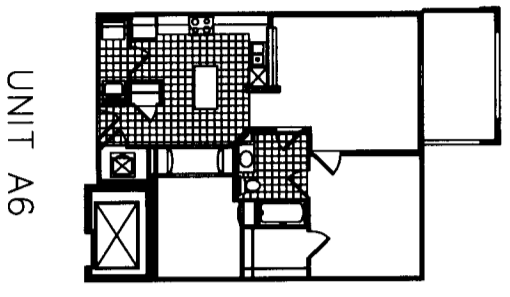

INFORMATION ON THIS SHEET OBTAINED FROM ARCHITECTURAL PLAN RELEASED BY THE HOUSING STUDIO ARCHITECTS AND WAS NOT FIELD VERIFIED.

GARDENS OF BRIDGEHAMPTON,
A CONDOMINIUM

MILLER LEGG
South Florida Office: 1800 North Douglas Road · Suite 200
Pembroke Pines, Florida · 33024-3200
954-436-7000 · Fax: 954-436-8664
www.millerlegg.com

Certificate of Authorization L.B. 6680

THIS SKETCH DOES NOT REPRESENT A BOUNDARY SURVEY

EXHIBIT

PROJECT NO.
05-00436

FILE NO.
11-1C-280

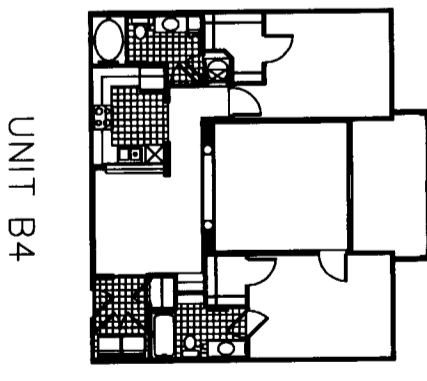
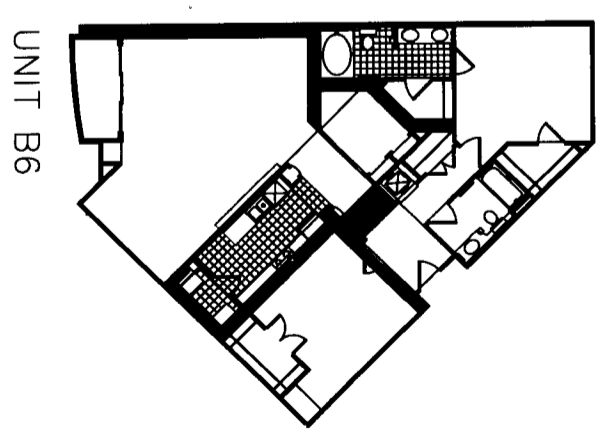
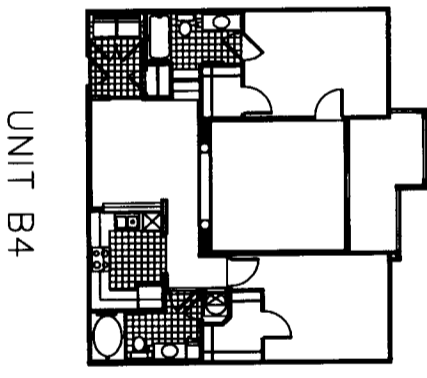
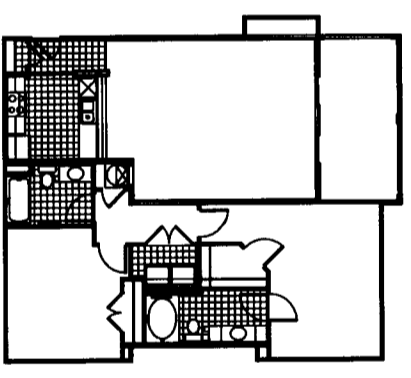
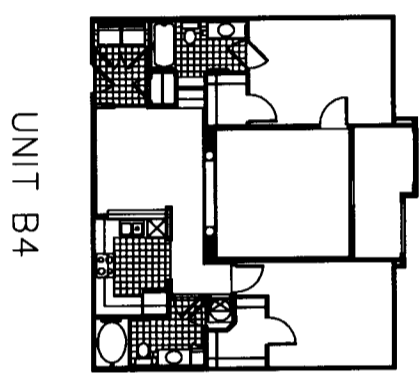
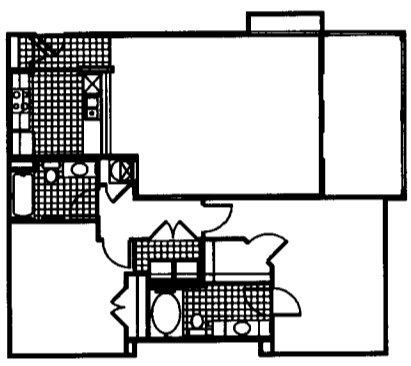
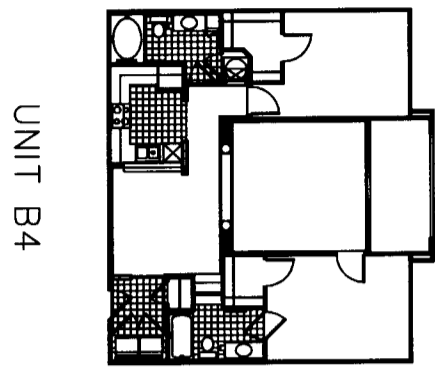
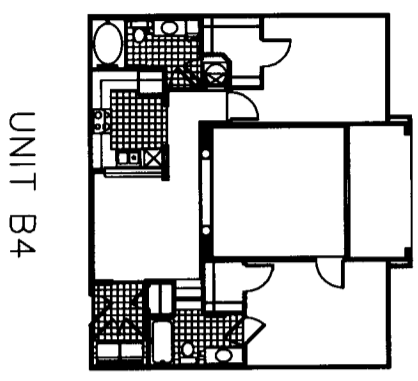

INFORMATION ON THIS SHEET OBTAINED FROM ARCHITECTURAL PLAN RELEASED BY THE HOUSING STUDIO ARCHITECTS AND WAS NOT FIELD VERIFIED.

GARDENS OF BRIDGEHAMPTON,
A CONDOMINIUM

MILLER LEGG
South Florida Office: 1800 North Douglas Road · Suite 200
Pembroke Pines, Florida · 33024-3200
954-436-7000 · Fax: 954-436-9664
www.millerlegg.com

Certificate of Authorization L.B. 6680

THIS SKETCH DOES NOT REPRESENT A BOUNDARY SURVEY

EXHIBIT

PROJECT NO.
05-00436

FILE NO.
11-1C-280

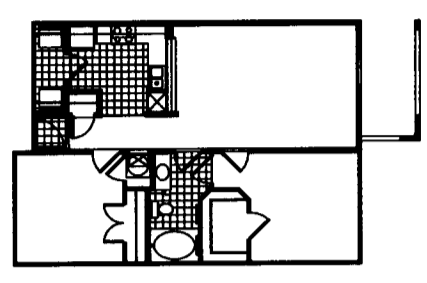

UNIT B1

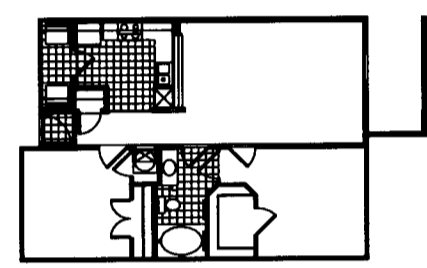

UNIT B1

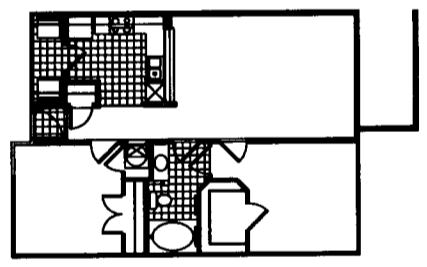

UNIT B1

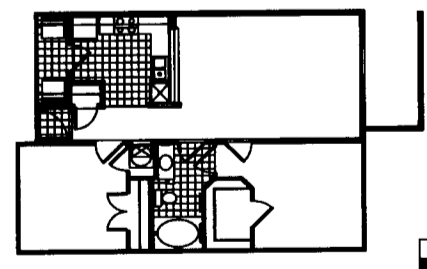

UNIT B1

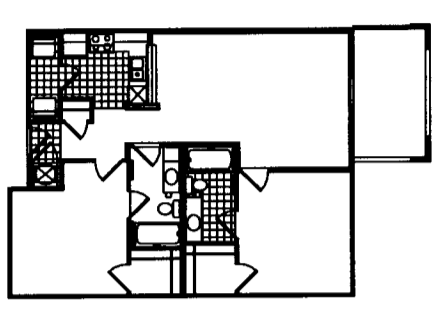

UNIT B3

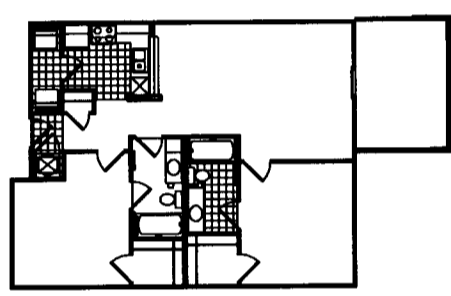

UNIT B3

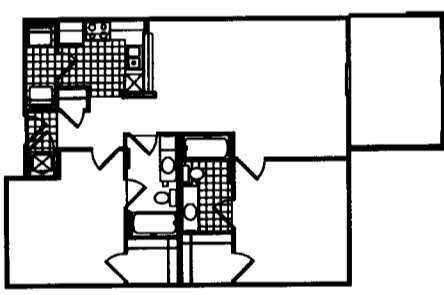

UNIT B3

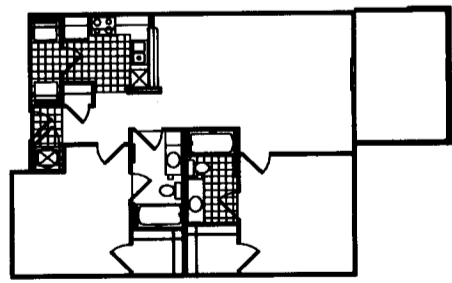

UNIT B3

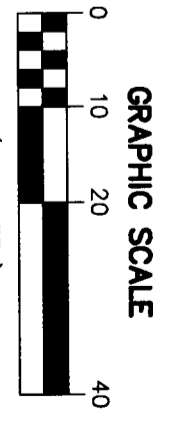

GRAPHIC SCALE
(IN FEET)
1 INCH = 20 FEET

INFORMATION ON THIS SHEET OBTAINED FROM
ARCHITECTURAL PLAN RELEASED BY THE HOUSING STUDIO
ARCHITECTS AND WAS NOT FIELD VERIFIED.

GARDENS OF BRIDGEHAMPTON,
A CONDOMINIUM

MILLER LEGG

South Florida Office: 1800 North Douglas Road · Suite 200
Pembroke Pines, Florida · 33024-3200
954-436-7000 · Fax: 954-436-8664
www.millerlegg.com

Certificate of Authorization L.B. 6680

THIS SKETCH DOES NOT REPRESENT A BOUNDARY SURVEY

EXHIBIT

PROJECT NO.
05-00436

FILE NO.
11-1C-280

EXHIBIT "B"

GARDENS OF BRIDGEHAMPTON, A CONDOMINIUM

UNIT OWNERS UNDIVIDED SHARE IN THE COMMON ELEMENTS
AND PERCENTAGE OF SHARING COMMON EXPENSES
AND OWNING COMMON SURPLUS

GARDENS OF BRIDGEHAMPTON, A CONDOMINIUM

UNIT OWNER UNDIVIDED SHARE IN THE COMMON ELEMENTS AND FRACTIONAL SHARES OF SHARING COMMON EXPENSES AND OWNING COMMON SURPLUS

Both the fractional shares of ownership of Common Elements and the Common Expenses of the Units were apportioned by grouping the Units into Types and allocating points to each type as follows: The ownership share of the Common Elements and Common Expenses assigned to each unit shall be based upon the total square footage of each unit in uniform relationship to the total square footage of each other unit in the condominium.

The fractional shares for each Unit were arrived at as follows:

UNIT TYPE	UNIT #	UNIT Sq. Ft.	BED/BATH	UNDIVIDED INTEREST
BUILDING 1				
B3	101	975	2 BR / 2 BA	975 / 357,647
B1	102	891	2 BR / 1 BA	891 / 357,647
B3	103	975	2 BR / 2 BA	975 / 357,647
B1	104	891	2 BR / 1 BA	891 / 357,647
A5	105	849	1 BR / 1 BA	849 / 357,647
A6	106	890	1 BR / 1 BA W/DEN	890 / 357,647
B1	107	891	2 BR / 1 BA	891 / 357,647
B3	108	975	2 BR / 2 BA	975 / 357,647
B1	109	891	2 BR / 1 BA	891 / 357,647
A5	110	849	1 BR / 1 BA	849 / 357,647
A6	111	890	1 BR / 1 BA W/DEN	890 / 357,647
B1	112	891	2 BR / 1 BA	891 / 357,647
B3	113	975	2 BR / 2 BA	975 / 357,647
B1	114	891	2 BR / 1 BA	891 / 357,647
A5	115	849	1 BR / 1 BA	849 / 357,647
B3	116	975	2 BR / 2 BA	975 / 357,647
B1	117	891	2 BR / 1 BA	891 / 357,647
B3	118	975	2 BR / 2 BA	975 / 357,647
B1	119	891	2 BR / 1 BA	891 / 357,647
A5	120	849	1 BR / 1 BA	849 / 357,647
B3	121	975	2 BR / 2 BA	975 / 357,647
B1	122	891	2 BR / 1 BA	891 / 357,647
B3	123	975	2 BR / 2 BA	975 / 357,647
B2	124	908	2 BR / 1 BA	908 / 357,647
A5	125	849	1 BR / 1 BA	849 / 357,647
B6	126	1,505	2 BR / 2 BA	1,505 / 357,647
A7	127	895	1 BR / 1 BA W/DEN	895 / 357,647
B1	128	891	2 BR / 1 BA	891 / 357,647
B3	129	975	2 BR / 2 BA	975 / 357,647
B2	130	908	2 BR / 1 BA	908 / 357,647
A5	131	849	1 BR / 1 BA	849 / 357,647
B6	132	1,505	2 BR / 2 BA	1,505 / 357,647
A7	133	895	1 BR / 1 BA W/DEN	895 / 357,647
B1	134	891	2 BR / 1 BA	891 / 357,647
B3	135	975	2 BR / 2 BA	975 / 357,647
B2	136	908	2 BR / 1 BA	908 / 357,647
A5	137	849	1 BR / 1 BA	849 / 357,647
B3	138	975	2 BR / 2 BA	975 / 357,647
B1	139	891	2 BR / 1 BA	891 / 357,647
B3	140	975	2 BR / 2 BA	975 / 357,647
B2	141	908	2 BR / 1 BA	908 / 357,647
A5	142	849	1 BR / 1 BA	849 / 357,647
A8	143	939	1 BR / 1 BA	939 / 357,647
B3	144	975	2 BR / 2 BA	975 / 357,647
B1	145	891	2 BR / 1 BA	891 / 357,647
B3	146	975	2 BR / 2 BA	975 / 357,647

UNIT TYPE	UNIT #	UNIT SQ. FT.	BED/BATH	UNDIVIDED INTEREST
<i>Building 1, continued</i>				
B2	147	908	2 BR / 1 BA	908 / 357,647
A5	148	849	1 BR / 1 BA	849 / 357,647
A9	149	1,040	1 BR / 1 BA	1,040 / 357,647
A7	150	895	1 BR / 1 BA W/DEN	895 / 357,647
B1	151	891	2 BR / 1 BA	891 / 357,647
B3	152	975	2 BR / 2 BA	975 / 357,647
B2	153	908	2 BR / 1 BA	908 / 357,647
A5	154	849	1 BR / 1 BA	849 / 357,647
A9	155	1,040	1 BR / 1 BA	1,040 / 357,647
A7	156	895	1 BR / 1 BA W/DEN	895 / 357,647
B1	157	891	2 BR / 1 BA	891 / 357,647
B3	158	975	2 BR / 2 BA	975 / 357,647
B2	159	908	2 BR / 1 BA	908 / 357,647
A5	160	849	1 BR / 1 BA	849 / 357,647
A8	161	939	1 BR / 1 BA	939 / 357,647
B3	162	975	2 BR / 2 BA	975 / 357,647
B1	163	891	2 BR / 1 BA	891 / 357,647
B3	164	975	2 BR / 2 BA	975 / 357,647
B2	165	908	2 BR / 1 BA	908 / 357,647
A5	166	849	1 BR / 1 BA	849 / 357,647
A8	167	939	1 BR / 1 BA	939 / 357,647
B3	168	975	2 BR / 2 BA	975 / 357,647
B1	169	891	2 BR / 1 BA	891 / 357,647
B3	170	975	2 BR / 2 BA	975 / 357,647
B2	171	908	2 BR / 1 BA	908 / 357,647
A5	172	849	1 BR / 1 BA	849 / 357,647
A9	173	1,040	1 BR / 1 BA	1,040 / 357,647
A7	174	895	1 BR / 1 BA W/DEN	895 / 357,647
B1	175	891	2 BR / 1 BA	891 / 357,647
B3	176	975	2 BR / 2 BA	975 / 357,647
B2	177	908	2 BR / 1 BA	908 / 357,647
A5	178	849	1 BR / 1 BA	849 / 357,647
A9	179	1,040	1 BR / 1 BA	1,040 / 357,647
A7	180	895	1 BR / 1 BA W/DEN	895 / 357,647
B1	181	891	2 BR / 1 BA	891 / 357,647
B3	182	975	2 BR / 2 BA	975 / 357,647
B2	183	908	2 BR / 1 BA	908 / 357,647
A5	184	849	1 BR / 1 BA	849 / 357,647
A8	185	939	1 BR / 1 BA	939 / 357,647
B3	186	975	2 BR / 2 BA	975 / 357,647
B1	187	891	2 BR / 1 BA	891 / 357,647
B3	188	975	2 BR / 2 BA	975 / 357,647
B2	189	908	2 BR / 1 BA	908 / 357,647
A5	190	849	1 BR / 1 BA	849 / 357,647
BUILDING 2				
B4	201	1,100	2 BR / 2 BA	1,100 / 357,647
C2	202	1,533	3 BR / 3 BA	1,533 / 357,647
B4	203	1,100	2 BR / 2 BA	1,100 / 357,647
A1	204	793	1 BR / 1 BA	793 / 357,647
A2	205	796	1 BR / 1 BA	796 / 357,647
A4	206	815	1 BR / 1 BA	815 / 357,647
B4	207	1,100	2 BR / 2 BA	1,100 / 357,647
C3	208	1,551	3 BR / 3 BA	1,551 / 357,647
B4	209	1,100	2 BR / 2 BA	1,100 / 357,647
A1	210	793	1 BR / 1 BA	793 / 357,647
A3	211	811	1 BR / 1 BA	811 / 357,647
A4	212	815	1 BR / 1 BA	815 / 357,647

UNIT TYPE	UNIT #	UNIT Sq. Ft.	BED/BATH	UNDIVIDED INTEREST
<i>Building 2, continued</i>				
B5	213	1,222	2 BR / 2 BA	1,222 / 357,647
B4	214	1,100	2 BR / 2 BA	1,100 / 357,647
C1	215	1,509	3 BR / 3 BA	1,509 / 357,647
B4	216	1,100	2 BR / 2 BA	1,100 / 357,647
A1	217	793	1 BR / 1 BA	793 / 357,647
A3	218	811	1 BR / 1 BA	811 / 357,647
A4	219	815	1 BR / 1 BA	815 / 357,647
B5	220	1,222	2 BR / 2 BA	1,222 / 357,647
BUILDING 3				
B4	301	1,100	2 BR / 2 BA	1,100 / 357,647
C2	302	1,533	3 BR / 3 BA	1,533 / 357,647
B4	303	1,100	2 BR / 2 BA	1,100 / 357,647
A1	304	793	1 BR / 1 BA	793 / 357,647
A2	305	796	1 BR / 1 BA	796 / 357,647
A4	306	815	1 BR / 1 BA	815 / 357,647
B4	307	1,100	2 BR / 2 BA	1,100 / 357,647
C3	308	1,551	3 BR / 3 BA	1,551 / 357,647
B4	309	1,100	2 BR / 2 BA	1,100 / 357,647
A1	310	793	1 BR / 1 BA	793 / 357,647
A3	311	811	1 BR / 1 BA	811 / 357,647
A4	312	815	1 BR / 1 BA	815 / 357,647
B5	313	1,222	2 BR / 2 BA	1,222 / 357,647
B4	314	1,100	2 BR / 2 BA	1,100 / 357,647
C1	315	1,509	3 BR / 3 BA	1,509 / 357,647
B4	316	1,100	2 BR / 2 BA	1,100 / 357,647
A1	317	793	1 BR / 1 BA	793 / 357,647
A3	318	811	1 BR / 1 BA	811 / 357,647
A4	319	815	1 BR / 1 BA	815 / 357,647
B5	320	1,222	2 BR / 2 BA	1,222 / 357,647
BUILDING 4				
B4	401	1,100	2 BR / 2 BA	1,100 / 357,647
C2	402	1,533	3 BR / 3 BA	1,533 / 357,647
B4	403	1,100	2 BR / 2 BA	1,100 / 357,647
A1	404	793	1 BR / 1 BA	793 / 357,647
A2	405	796	1 BR / 1 BA	796 / 357,647
A4	406	815	1 BR / 1 BA	815 / 357,647
B4	407	1,100	2 BR / 2 BA	1,100 / 357,647
C3	408	1,551	3 BR / 3 BA	1,551 / 357,647
B4	409	1,100	2 BR / 2 BA	1,100 / 357,647
A1	410	793	1 BR / 1 BA	793 / 357,647
A3	411	811	1 BR / 1 BA	811 / 357,647
A4	412	815	1 BR / 1 BA	815 / 357,647
B5	413	1,222	2 BR / 2 BA	1,222 / 357,647
B4	414	1,100	2 BR / 2 BA	1,100 / 357,647
C1	415	1,509	3 BR / 3 BA	1,509 / 357,647
B4	416	1,100	2 BR / 2 BA	1,100 / 357,647
A1	417	793	1 BR / 1 BA	793 / 357,647
A3	418	811	1 BR / 1 BA	811 / 357,647
A4	419	815	1 BR / 1 BA	815 / 357,647
B5	420	1,222	2 BR / 2 BA	1,222 / 357,647
BUILDING 5				
B4	501	1,100	2 BR / 2 BA	1,100 / 357,647
C2	502	1,533	3 BR / 3 BA	1,533 / 357,647

UNIT TYPE	UNIT #	UNIT Sq. Ft.	BED/BATH	UNDIVIDED INTEREST
<i>Building 5, continued</i>				
B4	503	1,100	2 BR / 2 BA	1,100 / 357,647
A1	504	793	1 BR / 1 BA	793 / 357,647
A2	505	796	1 BR / 1 BA	796 / 357,647
A4	506	815	1 BR / 1 BA	815 / 357,647
B4	507	1,100	2 BR / 2 BA	1,100 / 357,647
C3	508	1,551	3 BR / 3 BA	1,551 / 357,647
B4	509	1,100	2 BR / 2 BA	1,100 / 357,647
A1	510	793	1 BR / 1 BA	793 / 357,647
A3	511	811	1 BR / 1 BA	811 / 357,647
A4	512	815	1 BR / 1 BA	815 / 357,647
B5	513	1,222	2 BR / 2 BA	1,222 / 357,647
B4	514	1,100	2 BR / 2 BA	1,100 / 357,647
C1	515	1,509	3 BR / 3 BA	1,509 / 357,647
B4	516	1,100	2 BR / 2 BA	1,100 / 357,647
A1	517	793	1 BR / 1 BA	793 / 357,647
A3	518	811	1 BR / 1 BA	811 / 357,647
A4	519	815	1 BR / 1 BA	815 / 357,647
B5	520	1,222	2 BR / 2 BA	1,222 / 357,647
BUILDING 6				
B4	601	1,100	2 BR / 2 BA	1,100 / 357,647
C2	602	1,533	3 BR / 3 BA	1,533 / 357,647
B4	603	1,100	2 BR / 2 BA	1,100 / 357,647
A1	604	793	1 BR / 1 BA	793 / 357,647
A2	605	796	1 BR / 1 BA	796 / 357,647
A4	606	815	1 BR / 1 BA	815 / 357,647
B4	607	1,100	2 BR / 2 BA	1,100 / 357,647
C3	608	1,551	3 BR / 3 BA	1,551 / 357,647
B4	609	1,100	2 BR / 2 BA	1,100 / 357,647
A1	610	793	1 BR / 1 BA	793 / 357,647
A3	611	811	1 BR / 1 BA	811 / 357,647
A4	612	815	1 BR / 1 BA	815 / 357,647
B5	613	1,222	2 BR / 2 BA	1,222 / 357,647
B4	614	1,100	2 BR / 2 BA	1,100 / 357,647
C1	615	1,509	3 BR / 3 BA	1,509 / 357,647
B4	616	1,100	2 BR / 2 BA	1,100 / 357,647
A1	617	793	1 BR / 1 BA	793 / 357,647
A3	618	811	1 BR / 1 BA	811 / 357,647
A4	619	815	1 BR / 1 BA	815 / 357,647
B5	620	1,222	2 BR / 2 BA	1,222 / 357,647
BUILDING 7				
B4	701	1,100	2 BR / 2 BA	1,100 / 357,647
C2	702	1,533	3 BR / 3 BA	1,533 / 357,647
B4	703	1,100	2 BR / 2 BA	1,100 / 357,647
A1	704	793	1 BR / 1 BA	793 / 357,647
A2	705	796	1 BR / 1 BA	796 / 357,647
A4	706	815	1 BR / 1 BA	815 / 357,647
B4	707	1,100	2 BR / 2 BA	1,100 / 357,647
C3	708	1,551	3 BR / 3 BA	1,551 / 357,647
B4	709	1,100	2 BR / 2 BA	1,100 / 357,647
A1	710	793	1 BR / 1 BA	793 / 357,647
A3	711	811	1 BR / 1 BA	811 / 357,647
A4	712	815	1 BR / 1 BA	815 / 357,647
B5	713	1,222	2 BR / 2 BA	1,222 / 357,647

UNIT TYPE	UNIT #	UNIT Sq. Ft.	BED/BATH	UNDIVIDED INTEREST
<i>Building 7, continued</i>				
B4	714	1,100	2 BR / 2 BA	1,100 / 357,647
C1	715	1,509	3 BR / 3 BA	1,509 / 357,647
B4	716	1,100	2 BR / 2 BA	1,100 / 357,647
A1	717	793	1 BR / 1 BA	793 / 357,647
A3	718	811	1 BR / 1 BA	811 / 357,647
A4	719	815	1 BR / 1 BA	815 / 357,647
B5	720	1,222	2 BR / 2 BA	1,222 / 357,647
BUILDING 8				
B4	801	1,100	2 BR / 2 BA	1,100 / 357,647
C2	802	1,533	3 BR / 3 BA	1,533 / 357,647
B4	803	1,100	2 BR / 2 BA	1,100 / 357,647
A1	804	793	1 BR / 1 BA	793 / 357,647
A2	805	796	1 BR / 1 BA	796 / 357,647
A4	806	815	1 BR / 1 BA	815 / 357,647
B4	807	1,100	2 BR / 2 BA	1,100 / 357,647
C3	808	1,551	3 BR / 3 BA	1,551 / 357,647
B4	809	1,100	2 BR / 2 BA	1,100 / 357,647
A1	810	793	1 BR / 1 BA	793 / 357,647
A3	811	811	1 BR / 1 BA	811 / 357,647
A4	812	815	1 BR / 1 BA	815 / 357,647
B5	813	1,222	2 BR / 2 BA	1,222 / 357,647
B4	814	1,100	2 BR / 2 BA	1,100 / 357,647
C1	815	1,509	3 BR / 3 BA	1,509 / 357,647
B4	816	1,100	2 BR / 2 BA	1,100 / 357,647
A1	817	793	1 BR / 1 BA	793 / 357,647
A3	818	811	1 BR / 1 BA	811 / 357,647
A4	819	815	1 BR / 1 BA	815 / 357,647
B5	820	1,222	2 BR / 2 BA	1,222 / 357,647
BUILDING 9				
B4	901	1,100	2 BR / 2 BA	1,100 / 357,647
C2	902	1,533	3 BR / 3 BA	1,533 / 357,647
B4	903	1,100	2 BR / 2 BA	1,100 / 357,647
A1	904	793	1 BR / 1 BA	793 / 357,647
A2	905	796	1 BR / 1 BA	796 / 357,647
A4	906	815	1 BR / 1 BA	815 / 357,647
B4	907	1,100	2 BR / 2 BA	1,100 / 357,647
C3	908	1,551	3 BR / 3 BA	1,551 / 357,647
B4	909	1,100	2 BR / 2 BA	1,100 / 357,647
A1	910	793	1 BR / 1 BA	793 / 357,647
A3	911	811	1 BR / 1 BA	811 / 357,647
A4	912	815	1 BR / 1 BA	815 / 357,647
B5	913	1,222	2 BR / 2 BA	1,222 / 357,647
B4	914	1,100	2 BR / 2 BA	1,100 / 357,647
C1	915	1,509	3 BR / 3 BA	1,509 / 357,647
B4	916	1,100	2 BR / 2 BA	1,100 / 357,647
A1	917	793	1 BR / 1 BA	793 / 357,647
A3	918	811	1 BR / 1 BA	811 / 357,647
A4	919	815	1 BR / 1 BA	815 / 357,647
B5	920	1,222	2 BR / 2 BA	1,222 / 357,647
BUILDING 10				
B4	1001	1,100	2 BR / 2 BA	1,100 / 357,647
C2	1002	1,533	3 BR / 3 BA	1,533 / 357,647
B4	1003	1,100	2 BR / 2 BA	1,100 / 357,647

UNIT TYPE	UNIT #	UNIT SQ. FT.	BED/BATH	UNDIVIDED INTEREST
<i>Building 10, continued</i>				
A1	1004	793	1 BR / 1 BA	793 / 357,647
A2	1005	796	1 BR / 1 BA	796 / 357,647
A4	1006	815	1 BR / 1 BA	815 / 357,647
B4	1007	1,100	2 BR / 2 BA	1,100 / 357,647
C3	1008	1,551	3 BR / 3 BA	1,551 / 357,647
B4	1009	1,100	2 BR / 2 BA	1,100 / 357,647
A1	1010	793	1 BR / 1 BA	793 / 357,647
A3	1011	811	1 BR / 1 BA	811 / 357,647
A4	1012	815	1 BR / 1 BA	815 / 357,647
B5	1013	1,222	2 BR / 2 BA	1,222 / 357,647
B4	1014	1,100	2 BR / 2 BA	1,100 / 357,647
C1	1015	1,509	3 BR / 3 BA	1,509 / 357,647
B4	1016	1,100	2 BR / 2 BA	1,100 / 357,647
A1	1017	793	1 BR / 1 BA	793 / 357,647
A3	1018	811	1 BR / 1 BA	811 / 357,647
A4	1019	815	1 BR / 1 BA	815 / 357,647
B5	1020	1,222	2 BR / 2 BA	1,222 / 357,647
BUILDING 11				
B4	1101	1,100	2 BR / 2 BA	1,100 / 357,647
C2	1102	1,533	3 BR / 3 BA	1,533 / 357,647
B4	1103	1,100	2 BR / 2 BA	1,100 / 357,647
A1	1104	793	1 BR / 1 BA	793 / 357,647
A2	1105	796	1 BR / 1 BA	796 / 357,647
A4	1106	815	1 BR / 1 BA	815 / 357,647
B4	1107	1,100	2 BR / 2 BA	1,100 / 357,647
C3	1108	1,551	3 BR / 3 BA	1,551 / 357,647
B4	1109	1,100	2 BR / 2 BA	1,100 / 357,647
A1	1110	793	1 BR / 1 BA	793 / 357,647
A3	1111	811	1 BR / 1 BA	811 / 357,647
A4	1112	815	1 BR / 1 BA	815 / 357,647
B5	1113	1,222	2 BR / 2 BA	1,222 / 357,647
B4	1114	1,100	2 BR / 2 BA	1,100 / 357,647
B4	1116	1,100	2 BR / 2 BA	1,100 / 357,647
C1	1116	1,509	3 BR / 3 BA	1,509 / 357,647
A1	1117	793	1 BR / 1 BA	793 / 357,647
A3	1118	811	1 BR / 1 BA	811 / 357,647
A4	1119	815	1 BR / 1 BA	815 / 357,647
B5	1120	1,222	2 BR / 2 BA	1,222 / 357,647
BUILDING 12				
B4	1201	1,100	2 BR / 2 BA	1,100 / 357,647
C2	1202	1,533	3 BR / 3 BA	1,533 / 357,647
B4	1203	1,100	2 BR / 2 BA	1,100 / 357,647
A1	1204	793	1 BR / 1 BA	793 / 357,647
A2	1205	796	1 BR / 1 BA	796 / 357,647
A4	1206	815	1 BR / 1 BA	815 / 357,647
B5	1207	1,222	2 BR / 2 BA	1,222 / 357,647
B4	1208	1,100	2 BR / 2 BA	1,100 / 357,647
C3	1208	1,551	3 BR / 3 BA	1,551 / 357,647
B4	1210	1,100	2 BR / 2 BA	1,100 / 357,647
A1	1211	793	1 BR / 1 BA	793 / 357,647
A3	1212	811	1 BR / 1 BA	811 / 357,647
A4	1213	815	1 BR / 1 BA	815 / 357,647
B5	1214	1,222	2 BR / 2 BA	1,222 / 357,647

UNIT TYPE	UNIT #	UNIT Sq. Ft.	BED/BATH	UNDIVIDED INTEREST
<i>Building 12, continued</i>				
B4	1215	1,100	2 BR / 2 BA	1,100 / 357,647
C1	1215	1,509	3 BR / 3 BA	1,509 / 357,647
B4	1217	1,100	2 BR / 2 BA	1,100 / 357,647
A1	1218	793	1 BR / 1 BA	793 / 357,647
A3	1219	811	1 BR / 1 BA	811 / 357,647
A4	1220	815	1 BR / 1 BA	815 / 357,647
B5	1221	1,222	2 BR / 2 BA	1,222 / 357,647
BUILDING 13				
B4	1301	1,100	2 BR / 2 BA	1,100 / 357,647
C2	1302	1,533	3 BR / 3 BA	1,533 / 357,647
B4	1303	1,100	2 BR / 2 BA	1,100 / 357,647
A1	1304	793	1 BR / 1 BA	793 / 357,647
A2	1305	796	1 BR / 1 BA	796 / 357,647
A4	1306	815	1 BR / 1 BA	815 / 357,647
B5	1307	1,222	2 BR / 2 BA	1,222 / 357,647
B4	1308	1,100	2 BR / 2 BA	1,100 / 357,647
C3	1309	1,551	3 BR / 3 BA	1,551 / 357,647
B4	1310	1,100	2 BR / 2 BA	1,100 / 357,647
A1	1311	793	1 BR / 1 BA	793 / 357,647
A3	1312	811	1 BR / 1 BA	811 / 357,647
A4	1313	815	1 BR / 1 BA	815 / 357,647
B5	1314	1,222	2 BR / 2 BA	1,222 / 357,647
B4	1315	1,100	2 BR / 2 BA	1,100 / 357,647
C1	1316	1,509	3 BR / 3 BA	1,509 / 357,647
B4	1317	1,100	2 BR / 2 BA	1,100 / 357,647
A1	1318	793	1 BR / 1 BA	793 / 357,647
A3	1319	811	1 BR / 1 BA	811 / 357,647
A4	1320	815	1 BR / 1 BA	815 / 357,647
B5	1321	1,222	2 BR / 2 BA	1,222 / 357,647
BUILDING 14				
B4	1401	1,100	2 BR / 2 BA	1,100 / 357,647
C2	1402	1,533	3 BR / 3 BA	1,533 / 357,647
B4	1403	1,100	2 BR / 2 BA	1,100 / 357,647
A1	1404	793	1 BR / 1 BA	793 / 357,647
A2	1405	796	1 BR / 1 BA	796 / 357,647
A4	1406	815	1 BR / 1 BA	815 / 357,647
B4	1407	1,100	2 BR / 2 BA	1,100 / 357,647
C3	1408	1,551	3 BR / 3 BA	1,551 / 357,647
B4	1409	1,100	2 BR / 2 BA	1,100 / 357,647
A1	1410	793	1 BR / 1 BA	793 / 357,647
A3	1411	811	1 BR / 1 BA	811 / 357,647
A4	1412	815	1 BR / 1 BA	815 / 357,647
B5	1413	1,222	2 BR / 2 BA	1,222 / 357,647
B4	1414	1,100	2 BR / 2 BA	1,100 / 357,647
C1	1415	1,509	3 BR / 3 BA	1,509 / 357,647
B4	1416	1,100	2 BR / 2 BA	1,100 / 357,647
A1	1417	793	1 BR / 1 BA	793 / 357,647
A3	1418	811	1 BR / 1 BA	811 / 357,647
A4	1419	815	1 BR / 1 BA	815 / 357,647
B5	1420	1,222	2 BR / 2 BA	1,222 / 357,647
	352	357,647		357,647 / 357,647

*All Square footages shown are approximate
~ Breakdown on following page ~*

UNIT BREAKDOWN					
UNIT TYPE	UNIT AREA	NO. OF UNITS	TOTAL UNIT AREA	FRACTIONAL SHARE EACH	TOTAL FRACTIONAL SHARE
A1	793	39	30,927	793 / 357,647	30,927 / 357,647
A2	796	13	10,348	796 / 357,647	10,348 / 357,647
A3	811	26	21,086	811 / 357,647	21,086 / 357,647
A4	815	39	31,785	815 / 357,647	31,785 / 357,647
A5	849	16	13,584	849 / 357,647	13,584 / 357,647
A6	890	2	1,780	890 / 357,647	1,780 / 357,647
A7	895	6	5,370	895 / 357,647	5,370 / 357,647
A8	939	4	3,756	939 / 357,647	3,756 / 357,647
A9	1,040	4	4,160	1,040 / 357,647	4,160 / 357,647
B1	891	20	17,820	891 / 357,647	17,820 / 357,647
B2	908	12	10,896	908 / 357,647	10,896 / 357,647
B3	975	24	23,400	975 / 357,647	23,400 / 357,647
B4	1,100	78	85,800	1,100 / 357,647	85,800 / 357,647
B5	1,222	28	34,216	1,222 / 357,647	34,216 / 357,647
B6	1,505	2	3,010	1,505 / 357,647	3,010 / 357,647
C1	1,509	13	19,617	1,509 / 357,647	19,617 / 357,647
C2	1,533	13	19,929	1,533 / 357,647	19,929 / 357,647
C3	1,551	13	20,163	1,551 / 357,647	20,163 / 357,647
TOTAL		352	357,647		357,647 / 357,647

All Square footages shown are approximate.

EXHIBIT "C"

GARDENS OF BRIDGEHAMPTON, A CONDOMINIUM

ARTICLES OF INCORPORATION OF
GARDENS OF BRIDGEHAMPTON CONDOMINIUM ASSOCIATION, INC.



March 1, 2006

FLORIDA DEPARTMENT OF STATE
Division of Corporations

GARDENS OF BRIDGEHAMPTON CONDOMINIUM ASSOCIATION, INC.
8290 GATE PARKWAY WEST
JACKSONVILLE, FL 32216

The Articles of Incorporation for GARDENS OF BRIDGEHAMPTON CONDOMINIUM ASSOCIATION, INC. were filed on February 28, 2006, and assigned document number N06000002268. Please refer to this number whenever corresponding with this office.

Enclosed is the certification requested. To be official, the certification for a certified copy must be attached to the original document that was electronically submitted and filed under FAX audit number H06000053696.

A corporation annual report/uniform business report will be due this office between January 1 and May 1 of the year following the calendar year of the file/effective date year. A Federal Employer Identification (FEI) number will be required before this report can be filed. Please apply NOW with the Internal Revenue Service by calling 1-800-829-3676 and requesting form SS-4 or by going to their website at www.irs.ustreas.gov.

Please be aware if the corporate address changes, it is the responsibility of the corporation to notify this office.

Should you have questions regarding corporations, please contact this office at the address given below.

Loria Poole
Document Specialist
New Filings Section
Division of Corporations

Letter Number: 706A00014375

P.O BOX 6327 - Tallahassee, Florida 32314

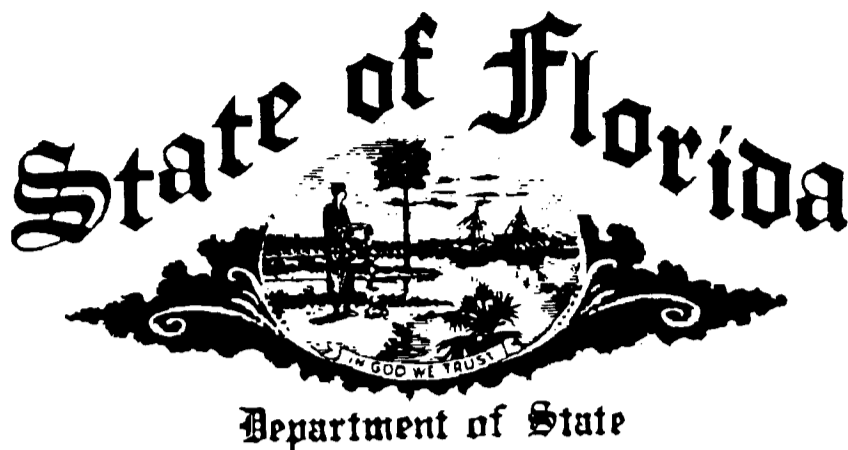

State of Florida
Department of State

I certify the attached is a true and correct copy of the Articles of Incorporation of GARDENS OF BRIDGEHAMPTON CONDOMINIUM ASSOCIATION, INC., a Florida corporation, filed on February 28, 2006, as shown by the records of this office.

I further certify the document was electronically received under FAX audit number H06000053696. This certificate is issued in accordance with section 15.16, Florida Statutes, and authenticated by the code noted below

The document number of this corporation is N06000002268.

Authentication Code: 706A00014375-030106-N06000002268-1/1

Given under my hand and the
Great Seal of the State of Florida,
at Tallahassee, the Capital, this the
First day of March, 2006



Sue M. Cobb
Sue M. Cobb
Secretary of State



State of Florida

Department of State

I certify from the records of this office that GARDENS OF BRIDGEHAMPTON CONDOMINIUM ASSOCIATION, INC. is a corporation organized under the laws of the State of Florida, filed on February 28, 2006.

The document number of this corporation is N06000002268.

I further certify that said corporation has paid all fees due this office through December 31, 2006, and its status is active.

I further certify that said corporation has not filed Articles of Dissolution.

I further certify that this is an electronically transmitted certificate authorized by section 15.16, Florida Statutes, and authenticated by the code, 706A00014375-030106-N06000002268-1/1, noted below.

Authentication Code: 706A00014375-030106-N06000002268-1/1

Given under my hand and the
Great Seal of the State of Florida,
at Tallahassee, the Capital, this the
First day of March, 2006



Sue M. Cobb
Sue M. Cobb
Secretary of State

**ARTICLES OF INCORPORATION
GARDENS OF BRIDGEHAMPTON CONDOMINIUM ASSOCIATION, INC.**

THE UNDERSIGNED INCORPORATOR, being a natural person competent to contract, for the purpose of forming a corporation not-for-profit under the laws of the State of Florida, does hereby adopt, subscribe and acknowledge the following Articles of Incorporation.

ARTICLE I. NAME

The name of the corporation shall be GARDENS OF BRIDGEHAMPTON CONDOMINIUM ASSOCIATION, INC. For convenience, the corporation shall be referred to in this instrument as the "Corporation."

ARTICLE II. PURPOSE AND POWERS

Section 1. Purpose: The purpose for which the Corporation is organized is to provide an entity for the operation and governance of Gardens of Bridgehampton, a Condominium (the "Condominium"), located upon lands in Duval County, Florida, said property being described in the duly recorded Declaration of Condominium applicable thereto.

The Corporation shall not be operated for profit and shall make no distribution of income to its members, directors or officers.

Section 2. Powers: The Corporation shall have all of the common-law and statutory powers of a corporation not-for-profit which are not in conflict with the terms of these Articles.

The Corporation shall have all of the powers and duties contemplated in the Declaration of Condominium and the Florida Condominium Act together with all of the powers and the duties reasonably necessary to operate the Condominium pursuant to the Declaration as it may be amended from time to time, and such other documents or agreements that may exist from time to time pertaining to the Condominium. The powers and duties, which the By-Laws may set forth in more detail, shall include, but shall not be limited to, the following specific powers and duties:

(a) To make and collect Assessments against members as Unit Owners to defray the costs, expenses and losses of the Condominium, and to make such other Special Assessments against Unit Owners as the Declaration of Condominium shall provide, and to enforce such levy of Assessments through a lien and the foreclosure thereof or by other action pursuant to the Declaration of Condominium.

(b) To use the proceeds of the Assessments in the exercise of its powers and duties, and as provided in the Declaration of Condominium.

(c) To maintain, repair, replace and operate the Condominium Property.

(d) To purchase insurance and enter into contracts for services, utilities and other purposes as may be deemed appropriate.

(e) To reconstruct improvements after casualty and further improve the Condominium Property.

(f) To make and amend reasonable rules and regulations.

(g) To perform such functions as may be specified in the Declaration of Condominium and the By-Laws.

(h) To enforce by legal means the provisions of the Florida Condominium Act, the Declaration of Condominium, these Articles, the By-Laws of the Corporation and such rules and regulations as may be promulgated.

(i) To employ personnel to perform the services required for proper operation of the Condominium.

(j) To lease, maintain, repair and replace the Common Elements as same are defined in the Declaration of Condominium.

(k) To acquire or enter into agreements acquiring leaseholds, memberships or other possessory or use interests in lands or facilities and to pay the rental, membership fees, operational, replacement and other expenses as Common Expenses.

(l) To purchase a Unit or Units of the Condominium for any purpose and to hold, lease, mortgage or convey such Units on terms and conditions approved by the Board of Directors.

(m) To exercise such other power and authority to do and perform every act and thing necessary and proper in the conduct of its business for the accomplishment of its purposes as set forth herein and as permitted by the applicable laws of the State of Florida.

(n) To contract for the management and maintenance of the Condominium Property and to authorize a management agent to assist the Corporation in carrying out its powers and duties by performing such

functions as the submission of proposals, collection of Assessments, and other sums due from Unit Owners, preparation of records, enforcement of rules and maintenance, repair and the replacement of the Common Elements with funds as shall be made available by the Corporation for such purposes. The Corporation and its officers shall, however, retain at all times the powers and duties granted by the Condominium documents and the Florida Condominium Act, including, but not limited to, the making of Assessments, promulgation of rules and execution of contracts on behalf of the Corporation.

(o) To bring suit as may be necessary to protect the Corporation's interests, the interests of the Corporation's Members, or the Condominium Property.

ARTICLE III. DEVELOPER

Gardens of Bridgehampton, LLC, a Delaware limited liability company, shall make and declare or has made and declared a certain Declaration of Condominium submitting to condominium ownership certain property described therein under the terms, covenants, and conditions expressed more fully therein; the Condominium is to be known as GARDENS OF BRIDGEHAMPTON, A CONDOMINIUM.

ARTICLE IV. TERM

The term for which this Corporation shall exist shall be perpetual unless terminated by another provision of the Declaration of Condominium of Gardens of Bridgehampton Condominium Association, Inc.

ARTICLE V. INCORPORATOR

The name and address of the incorporator of this Corporation is as follows:

LOUIS D. ZARETSKY, ESQ.
RITTER, ZARETSKY & LIEBER, LLP.
555 NE 15 STREET, STE 100
MIAMI, FLORIDA 33132

ARTICLE VI. OFFICERS

The officers of the Corporation shall be a President, one or more Vice Presidents, Secretary and Treasurer and such other officers as the Board of Directors may from time to time determine. The officers of this Corporation shall be elected for a term of one year, and until a successor shall be elected and qualified, by the Board of Directors at their annual meeting and in accordance with the provisions provided therefor in the By-Laws of the Corporation. Until transfer of the control of the Corporation to the Unit Owners other than the Developer has been accomplished, the officers need not be directors or members.

The names of the persons who shall serve as the first officers are:

Cassandra Capecchi	President
Holly Baker	Vice President
Louis Homsany	Secretary/Treasurer

ARTICLE VII. DIRECTORS

The affairs of the Corporation shall be managed by a Board of Directors composed of not less than three (3) directors. Until control of the Corporation is transferred to Unit Owners other than the Developer, the Developer shall be entitled to designate non-member directors to the extent permitted by the Florida Condominium Act. Except for non-member directors appointed by the Developer, all directors shall be elected at the annual membership meeting of the Corporation.

The first Board of Directors shall be comprised of three (3) persons who shall serve until their respective successors are elected (or designated) and qualified. The names and addresses of the members of the Board of Directors who shall serve as the first directors are:

CASSANDRA CAPECCHI
4770 Biscayne Boulevard
Miami, Florida 33137

HOLLY BAKER
4770 Biscayne Boulevard
Miami, Florida 33137

LOUIS HOMSANY
4770 Biscayne Boulevard
Miami, Florida 33137

ARTICLE VIII. BY-LAWS

The initial By-Laws of the Corporation shall be attached as an exhibit to the Declaration of Condominium for the Condominium and shall be adopted by the first Board of Directors.

ARTICLE IX. MEMBERS

Membership in the Corporation shall automatically consist of and be limited to all of the record owners of Units in the Condominium. Transfer of Unit ownership, either voluntary or by operation of law, shall terminate membership in the Corporation and said membership is to become vested in the transferee. If Unit ownership is vested in more than one person then all of the persons so owning said Unit shall be members eligible to hold office, attend meetings, etc., but the Owner(s) of each Unit shall only be entitled to one vote as a member of the Corporation. The manner of designating voting members and exercising voting rights shall be determined by the By-Laws.

ARTICLE X. AMENDMENTS

Amendments to these Articles of Incorporation shall be made in the following manner:

(a) The Board of Directors shall adopt a resolution setting forth the proposed amendment and, if there are members of the Corporation, the Board shall direct that it be submitted to a vote at a meeting of the members, which may be either the annual or a special meeting. If there are no members of the Corporation, the amendment shall be adopted by a vote of the majority of directors and the provisions for adoption by members shall not apply.

(b) Written notice setting forth the proposed amendment or a summary of the changes to be effected thereby shall be given to each member of record entitled to vote thereon within the time and in the manner provided in Article III, Section 2 of the By-Laws for the giving of notice of meetings of members. If the meeting is an annual meeting, the proposed amendment or such summary may be included in the notice of such annual meeting.

(c) At such meeting, a vote of the members entitled to vote thereon shall be taken on the proposed amendment. The proposed amendment shall be adopted upon receiving the affirmative vote of a majority of the votes of all members of the Corporation entitled to vote thereon.

No amendment to these Articles of Incorporation shall be made which affects any of the rights and privileges provided to the Developer in the Condominium documents without the written consent of the Developer.

ARTICLE XI. PRINCIPAL PLACE OF BUSINESS

The principal place of business of the Corporation shall be 8290 Gate Parkway West, Jacksonville, Florida 32216, or at such other place or places as may be designated from time to time.

ARTICLE XII. REGISTERED OFFICE AND AGENT

The street address of the initial registered office of the Corporation and the name of the initial registered agent at that address are:

LOUIS D. ZARETSKY, ESQ.
RITTER, ZARETSKY & LIEBER, LLP.
555 NE 15 STREET, STE 100
MIAMI, FLORIDA 33132

ARTICLE XIII. INDEMNIFICATION

The Corporation shall indemnify every director and every officer, his heirs, executors and administrators, against all loss, cost and expense reasonably incurred by him in connection with any action, suit or proceeding to which he may be made a party by reason of his being or having been a director or officer of the Corporation, including reasonable counsel fees, except as to matters wherein he shall be finally adjudged in such action, suit or proceedings to be liable for or guilty of gross negligence or willful misconduct. The foregoing rights shall be in addition to and not exclusive of all other rights to which such director or officer may be entitled.

~ signatures on following page ~

IN WITNESS WHEREOF, the subscribing Incorporator has hereunto set his hand and seal and caused these Articles of Incorporation to be executed this 28 day of Feb, 2006.

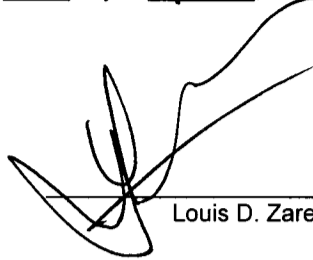

Louis D. Zaretsky

STATE OF FLORIDA
COUNTY OF ~~DUVAL~~ Dade

The foregoing instrument was acknowledged before me this 28 day of Feb, 2006, by Louis D. Zaretsky, being known to me to be the person who executed the foregoing Articles of Incorporation of GARDENS OF BRIDGEHAMPTON CONDOMINIUM ASSOCIATION, INC. who is personally known to me or has produced _____ as identification.

My Commission Expires: 6/02/07

(AFFIX NOTARY SEAL)



J. M. Grimes
Commission #DD218956
Expires: Jun 02, 2007
Bonded Thru
Atlantic Bonding Co., Inc.

(Signature)
Name: J.M. Grimes
(Legibly Printed)
Notary Public, State of Florida
DD 218956
(Commission Number, if any)

ACCEPTANCE OF DESIGNATION OF REGISTERED AGENT

The undersigned, having been named as registered agent and to accept service of process for GARDENS OF BRIDGEHAMPTON CONDOMINIUM ASSOCIATION, INC. hereby accepts the appointment as registered agent and agrees to act in such capacity. The undersigned further agrees to comply with the provisions of all statutes relating to the proper and complete performance of his duties and is familiar with and accepts the obligations of his position as registered agent.



Name: Louis D. Zaretsky
Registered Agent

STATE OF FLORIDA)
COUNTY OF MIAMI-DADE)

I HEREBY CERTIFY that on this 28 day of Feb, 2006, personally appeared before me, an officer duly authorized to administer oaths and take acknowledgments, LOUIS D. ZARETSKY, ESQ., to me known to be the individual described in and who executed the foregoing instrument as registered agent to the Articles of Incorporation of GARDENS OF BRIDGEHAMPTON CONDOMINIUM ASSOCIATION, INC., a Florida non-profit corporation, and he severally acknowledged to me that he signed and executed such instrument for the uses and purposes therein stated.

IN WITNESS WHEREOF, I have set my hand and official seal in the County and State aforesaid on the day and year last above written.



J. M. Grimes
Commission #DD218956
Expires: Jun 02, 2007
Bonded Thru
Atlantic Bonding Co., Inc.



Notary Public, State of Florida

My commission expires: 6/02/07

EXHIBIT "D"

GARDENS OF BRIDGEHAMPTON, A CONDOMINIUM

BY-LAWS OF
GARDENS OF BRIDGEHAMPTON CONDOMINIUM ASSOCIATION, INC.

BY-LAWS

OF

GARDENS OF BRIDGEHAMPTON CONDOMINIUM ASSOCIATION, INC.

A Florida Corporation Not for Profit

ARTICLE ONE

Organization

Section 1. The name of this organization shall be GARDENS OF BRIDGEHAMPTON CONDOMINIUM ASSOCIATION, INC.

Section 2. The organization may, by a vote of the Unit Owners, change its name.

ARTICLE TWO

Purposes

The following are the purposes for which this organization has been established:

Section 1. To serve the recreational and maintenance needs of the Owners of the Condominium Units constructed upon the real property described on Exhibit "A" of the Declaration of Condominium to which this Exhibit "D" is attached.

Section 2. To maintain, manage, operate, administer and improve the real property upon which the recreational facilities are to be constructed; and further, to maintain the facilities and improvements, including personal property, thereon.

Section 3. For the purposes set forth in the Articles of Incorporation of this organization and the Declaration Condominium of GARDENS OF BRIDGEHAMPTON, A CONDOMINIUM.

Section 4. For such other purpose as the Board Directors may from time to time deem necessary for the efficient operation of the recreational facilities and Common Elements and Limited Common Elements contemplated hereby.

ARTICLE THREE

Meetings of Membership

Section 1. Place: All meetings of the Association membership shall be held at the office of the Association or such other place as may be designated in the notice.

Section 2. Annual Meeting:

(a) The first Annual Meeting shall occur within one hundred (100) days of the recordation of the Declaration of Condominium and annually thereafter. All members of the Board of Directors to be elected by Unit Owners, other than the Developer, shall be elected by plurality vote. The Developer shall have the right to appoint all members of the Board of Directors, unless and until required otherwise by the provisions of the Declaration of Condominium and Florida Statutes.

(b) Subsequent to the first Annual Meeting, regular Annual Meetings shall be held in the month of November of each year upon date appointed by the Board of Directors. No meeting shall be held on a legal holiday. At least fourteen (14) days prior to the Annual Meeting, unless a Unit Owner waives, in writing, the right to receive notice of the Annual Meeting by mail, written notice including an agenda, shall be mailed by regular mail to each member of the Association at the address which the Developer initially identifies for that purpose. Where the Unit is owned by more than one person, the Association shall provide notice, for meetings and all other purposes, to the address initially identified by the Developer and thereafter, as one or more of the Unit Owners shall so advise the Association in writing, or if no address is given or the Unit Owners do not agree to the address provided on the deed of record. An officer of the Association or the manager or other person providing notice of the Association meeting shall provide an affidavit or United States Postal Service certificate of mailing, to be included in the official records of the Association, affirming that the notice was mailed or hand delivered in accordance herewith, to each Unit Owner at the address last furnished to the Association. Notice shall be posted in a conspicuous place on the condominium property at least fourteen (14) continuous days preceding the annual meeting. Upon notice to the Unit Owners, the Board shall, by duly adopted rule, designate a specific location on the condominium property upon which all notices of Unit Owners' meetings shall be posted.

(c) At the Annual Meetings, the membership of the Association shall elect, by plurality vote, a Board of Directors and transact such other business as may properly come before the meeting. The Directors so elected at the Annual Meeting shall constitute the Board Directors until the next Annual Meeting of the members of the Association and the election and qualification of their successors.

Section 3. Membership List: At least fifteen (15) days before every election of the Directors, a complete list of members entitled to vote at said election, arranged numerically by Condominium Units, shall be produced and kept for said fifteen (15) day period and during the election at the office of the Association and shall be open to examination by any member during such period.

Section 4. Special Meetings:

(a) Special Meetings of the members, for any purpose or purposes, unless otherwise prescribed by statute (including, but not limited to, the provisions of Chapter 718.112 (2) (e) and (j), Florida Statutes, regarding the percentage required to call certain special meetings, regarding budget and recall of Board Members), or Secretary at the request, in writing, of members holding not less than twenty five (25%) percent of the voting interest in the Association. Such request shall state the purpose, or purposes, of the proposed meeting.

(b) Written notice of a Special Meeting of members, stating time, place and object thereof, shall be mailed by regular mail to each member entitled to vote thereat, at such address as appears on the books of the Association, at least fourteen (14) days before such meeting. Also, written notice of any meeting at which non-emergency special assessments or at which amendments to rules regarding Units will be proposed, discussed or approved shall be mailed or delivered to the Unit Owners and posted conspicuously on the Condominium Property no less than fourteen (14) days prior to the meeting. Evidence of compliance with his fourteen (14) day notice shall be made by an Affidavit executed by the Secretary and filed among the official records of the Association.

(c) Business transaction at all Special Meetings shall be confined to the purposes stated in the notice thereof.

Section 5. Proxies: Votes may be cast in person or by proxy in accordance with applicable law. Proxies must be filed with the Secretary of the Association prior to the meeting. If more than one (1) person owns a Condominium Unit (such as husband and wife), all must sign the proxy for it to be valid.

Section 6. Quorum: The presence in person or representation by written proxy of the members holding at least fifty (50%) percent of the total voting interest in the Association shall be requisite to and shall constitute a quorum at all meetings of the members for the transaction of business, except as otherwise provided by statute, or by these By-Laws. If, however, such quorum shall not be present, the President, or in his absence, the Vice President; or in his absence, any other appropriate officer or director may adjourn the meeting to a time within fifteen (15) days thereof at the same place to be announced at the meeting by the person adjourning same and a notice of such new meeting to be posted conspicuously upon the Condominium Property forty eight (48) continuous hours preceding the meeting. The meeting shall continue to be adjourned in this manner until a quorum shall be present or represented. Notwithstanding anything contained herein to the contrary, at such new meeting or meetings (if additional meetings are necessary in order to obtain the reduced quorum as hereinafter provided), the presence in person or representation by written proxy of the members holding at least one-third (1/3) of the voting interest of the Association shall be requisite to and shall constitute a quorum at such new meetings; it being intended that, in the event a majority quorum cannot be obtained at any meeting of the members, the quorum requirement be reduced for the purposes of the new meeting or meetings to which the original meeting is adjourned only. At such new meeting or meetings, if necessary, at which a quorum (at least one-third (1/3) of the voting interest of the Association present in person or represented by proxy) exists, any business may be transacted which might have been transacted at the meeting originally called. Although any proxy shall be valid at the original meeting and any lawful adjourned meeting or meetings thereof, the Condominium Act shall control (in the event it limits the validity of proxies as it presently does for a period no longer than ninety (90) days after the date of the first meeting for which it was given). F.S. 718.112(2)(b)(2).

Section 7. Vote Required to Transact Business: When a quorum is present at any meeting, a majority of the Unit Owners total votes present in person or represented by written proxy (subject to the restrictions below) at such meeting shall decide any question brought before the meeting, unless the question is one upon which, by express provisions of the statutes of the Declaration of Condominium or by these By-Laws, a different vote is required, in which case such express provisions shall govern and control the voting on such issue. Notwithstanding the foregoing or anything to the contrary in these Bylaws, the use of proxies shall be restricted as follows: Limited proxies must be used for votes taken to waive or reduce reserves; to waive financial statement requirements; to amend the declaration, articles or bylaws; to elect board members in the case of recall; and for any other matter for which this chapter requires or permits a vote of the unit owners. General proxies may also be used for the purpose of obtaining a quorum.

Section 8. Right to Vote and Designation of Voting Member: If a Condominium Unit is owned by one person, his right to vote shall be established by the recorded title to the Unit. If a Condominium Unit is owned by more than one person, the person entitled to cast the vote for the Unit shall be designated in a certificate, signed by all of the recorded Owners of the Unit and filed with the Secretary of the Association. If a Condominium Unit is owned by a corporation, the officer or employee thereof entitled to cast the vote of the Unit for the corporation shall be designated in a certificate for this purpose, signed by the President or Vice President, attested to by the Secretary or Assistant Secretary of the corporation and filed with the Secretary of the Association. The person designated in such certificate who is entitled to cast the vote for a Unit shall be known as the "voting member." If such a certificate is not on file with the Secretary of the Association for a Unit owned by more than one person or by a corporation, the vote of the Unit owned by more than one person or by a corporation, the vote of the Unit concerned shall not be considered in determining the requirement for a quorum, or for any purpose requiring the approval of a person entitled to cast the vote for the Unit, except if said Unit is owned by a husband and wife. Such certificates shall be valid until revoked or until superseded by a subsequent certificate, or until change in the ownership of the Unit concerned. If a Condominium Unit is owned jointly by a husband and wife, the following three (3) provisions are applicable thereto:

(a) They may, but they shall not be required to, designate a voting member.

(b) If they do not designate a voting member, and if both are present at a meeting and are unable to concur in their decision upon any subject requiring a vote, they shall lose their right to vote on that subject at that meeting. (As provided herein, the vote of a Unit is not divisible.)

(c) Where they do not designate a voting member, and only one is present at a meeting, the person present may cast the Unit vote just as though he or she owned the Unit individually and without establishing the concurrence of the absent person.

Section 9. Waiver and Consent: Whenever the vote of a member at a meeting is required or permitted by any provision of the statutes or these By-Laws to be taken in connection with any action of the Association, the meeting and vote of members may be dispensed with if the members holding a majority of the Unit Owners total votes which would have been entitled to vote upon the action, if such meeting were held, shall consent in writing to such action being taken; however, notice of such action shall be given to all members unless all members approve such action.

Section 10. Order of Business: Other than the Annual Meeting, the proposed order of business at all meetings of the Association will be:

- (a) Determination of Quorum;
- (b) Proof of Notice of Meeting or Waiver of Notice;
- (c) Reading of Minutes of Prior Meeting;
- (d) Officers' Reports;
- (e) Committee Reports;
- (f) Unfinished Business;
- (g) New Business; and,
- (h) Adjournment.

The first order of business at the Annual Meeting shall be the collection of election ballots, as required by rule 61B-23.0021(10)(a), FAC.

Section 11. Election of Board: The members of the Board of Administration shall be elected by written ballot or voting machine. Except in the case of recall, proxies shall not be used in electing the Board of Administration, either in general elections or elections to fill vacancies caused by resignation, or otherwise, unless otherwise provided in Chapter 718, Florida Statutes. Limited proxies may be used to elect or replace board members in the event of recall. Not less than 60 days before a scheduled election, the Association shall mail or deliver, whether by separate Association mailing or included in another Association mailing or delivery including regularly published newsletters, to each Unit Owner entitled to vote, a first notice of the date of the election. Any Unit Owner or other eligible person desiring to be a candidate for the board of administration must give written notice to the Association not less than 40 days before a scheduled election. Together with the written notice and agenda, the Association shall then mail or deliver a second notice of the election meeting to all Unit Owners entitled to vote therein, together with a ballot which shall list all candidates. Upon request of a candidate, the Association shall include an information sheet, no larger than 8 1/2 inches by 11 inches, which must be furnished by the candidate not less than 35 days before the election, to be included with the mailing of the ballot, with the costs of mailing and copying to be borne by the Association. However, the Association has no liability for the contents of the information sheets prepared by the candidates. The division shall by rule establish voting procedures consistent with the provisions contained herein, including rules providing for the secrecy of ballots. Elections shall be decided by a plurality of those ballots cast. There shall be no quorum requirement; however, at least 20 percent of the eligible votes must cast a ballot in order to have a valid election of members of the Board of Administration. No Unit Owner shall permit any other person to vote his ballot, and any such ballots improperly cast shall be deemed invalid. A Unit Owner who needs assistance in casting the ballot for the reasons stated in Section 101.051, Florida Statutes, may obtain assistance in casting the ballot. Any Unit Owner violating this provision may be fined by the Association in accordance with Section 718.303, Florida Statutes. The regular election shall occur on the date of the annual meeting. Notwithstanding the provisions of this paragraph, an election and balloting are not required unless more candidates file notices of intent to run or are nominated than vacancies exist on the board.

Section 12. Unit Owner Participation: Unit Owners shall have the right to participate in meetings of Unit Owners with reference to all designated agenda items. However, the Association may adopt reasonable rules governing the frequency, duration and manner of Unit Owner participation. Any Unit Owner may tape record or videotape a meeting of the Unit Owners, subject to rules adopted by the Division.

ARTICLE FOUR

Voting

Section 1. The Owners(s) of each Condominium Unit shall be entitled to one (1) vote. If a Condominium Unit Owner owns more than one (1) Unit, he shall be entitled to vote for each Unit owned. The vote of a Condominium Unit shall not be divisible.

Section 2. For the election of Directors, voting shall be by secret ballot. When voting by ballot (for Director or otherwise), the Chairman of the meeting, immediately prior to the commencement of balloting, shall appoint a committee of three (3) members who will act as "Inspectors of Election" and who shall, at the conclusion of the balloting, certify in writing the results, and such certificate shall be annexed to the Minutes of the meeting.

ARTICLE FIVE

Board of Directors

Section 1. The business of this Association shall be governed by a Board of Directors consisting of three (3) persons. All Directors, other than the Developer or his designated agents, shall be members of the Association.

Section 2. The Directors to be chosen for the ensuing year shall be chosen at the Annual Meeting of this Association by plurality vote; and they shall serve for a term of one (1) year.

Section 3. The Board of Directors shall have the control and management of the affairs and business of this Association and shall have the right to establish reserves or Assessments for betterment of the Condominium Property. Said Board of Directors shall only act in the name of the Association when it shall be regularly convened by its Chairman and after due notice to all Directors of such meeting.

Section 4. All meetings of the Board of Directors of the Association shall be open to the members of the Association and notices of such meetings, stating the place and time thereof and including an identification of agenda items, shall be posted conspicuously, on the condominium property, at least forty eight (48) continuous hours prior to any such meeting to call the members' attention thereto provided, however, in the event of an emergency, said notice shall not be required. Any item not included on the notice may be taken up on an emergency basis by at least a majority plus one of the members of the Board of Administration. Such emergency action shall be noticed and ratified at the next regular meeting of the Board of Administration.

Section 5. The organizational meeting of a newly elected Board of Directors (at which meeting officers for the coming year shall be elected) shall be held within ten (10) days of the election of the new Board at such time and place as shall be fixed by the Chairman of the meeting at which they were elected.

Section 6. A majority of the members of the Board of Directors shall constitute a quorum, and the meetings of the Board of Directors shall be held regularly at such time and place as the Board of Directors shall designate.

Section 7. Each Director shall have one (1) vote, and such voting may not be by proxy.

Section 8. The Board of Directors may make such rules and regulations covering its meeting as it may, in its discretion, determine necessary.

Section 9. The Board of Directors may establish a schedule of regular meetings to be held at such time and place as the Board of Directors may designate. Notice of such regular meetings shall, nevertheless, be given to each Director personally or by mail, telephone or telegraph, at least five (5) days prior to the day named for such meeting.

Section 10. Special meetings of the Board of Directors may be called by the President, or, in his absence, by the vice president, or by a majority of the members of the Board of Directors, by giving five (5) days notice, in writing, to all of the members of the Board of Directors of the time and place of said meeting. All notices of Special Meetings shall state the purpose of the meeting.

Section 11. Before or at any meeting of the Board of Directors, any Director may waive notice of such meeting, and such waiver shall be deemed equivalent to the giving of notice. Attendance by a Director at any meeting of the Board, shall be a waiver of notice by him of the time and place thereof. If all the Directors are present at any meeting of the Board, no notice to Directors shall be required and any business may be transacted at such meeting, however, the notice required under Article Five, Section 4, shall still be posted.

Section 12. Vacancies in the Board of Directors shall be filled as follows:

(a) If the vacancy is for a Board member appointed by the Developer, the Developer shall have the right to designate the replacement Director.

(b) Any vacancy occurring on the board of directors prior to the expiration of a term, except in the case of a vacancy caused by recall, may be filled by the affirmative vote of the majority of the remaining directors, even if the remaining directors constitute less than a quorum, or by the sole remaining director.

Section 13. The President of the Association by virtue of his office shall be Chairman of the Board of Directors and preside at meetings of the membership. The removal process of Directors herein described shall not apply to Directors elected, appointed or designated by the Developer who may remove any such Director in its sole discretion and who shall thereafter designate the successive Director.

Section 14. A Director may be removed either with or without cause at any time by a vote of the majority of the Association's membership at any regular or special meeting of the membership of the Association or by agreement in writing by a majority of all voting interests; (except for the first Board of Directors and except as provided in Article Nine of these By-Laws) provided that before any Director is removed from office, he shall be notified in writing that a motion to remove him will be made prior to the meeting at which said motion is made, and such Director is given an opportunity to be heard at such meeting should he be present, prior to the vote of this removal.

Section 15. The first Board of Directors as designated by the Developers shall consist of:

CASSANDRA CAPECCHI
4770 Biscayne Boulevard
Miami, Florida 33137

HOLLY BAKER
4770 Biscayne Boulevard
Miami, Florida 33137

LOUIS HOMSANY
4770 Biscayne Boulevard
Miami, Florida 33137

who shall hold office and exercise all powers of the Board of Directors until the first membership meeting as set forth in Article Three, Section 2(a) of these By-Laws; provided any and all of said Directors shall be subject to replacement by the Developer.

Section 16. Power and Duties: The Board of Directors of the Association shall have the powers and duties necessary for the administration of the affairs of the Association and may do all such acts and things as are not prohibited by law or by the Declaration of Condominium, this Association's Articles of Incorporation, or these By-Laws, or directed to be exercised and done by Unit Owners. These powers shall specifically include, but shall not be limited to, the following:

(a) To exercise all powers specifically set forth in the Declaration of Condominium, this Association's Articles of Incorporation, these By-Laws, and in the Condominium Act, and all powers incidental thereto.

(b) To make and levy special and regular Assessments, collect said Assessments, and use and expend the Assessments to carry out the purposes and powers of the Association.

(c) To employ, dismiss and control the personnel necessary for the maintenance and operation of the project, and of the Common Elements and facilities, including the right and power to employ attorneys, accountants, contractors and other professional as the need arises.

(d) To make and amend regulations respecting the operation and use of the Common Elements

and Condominium Property and facilities, and the use and maintenance of the Condominium Units therein, and the recreational area and facilities.

(e) To contract for the management and maintenance of the Condominium Property and to authorize a management agent to assist the Association in carrying out its powers and duties by performing such functions as the submission of proposals, collection of Assessment, preparation of records, enforcement of rules and maintenance, repair and replacement of the Common Elements with funds as shall be made available by the Association for such purposes. The Association and its officers shall, however, retain at all times the powers and duties granted by the Condominium documents and the Condominium Act, including, but not limited to, the making of Assessment, promulgation of rules and execution of contracts on behalf of the Association.

(f) Designate one (1) or more committees which, to the extent provided in the resolution designating said committee, shall have the powers of the Board of Directors in the management and affairs and business of the Association, provided, however, that the powers of a committee shall be limited, and no committee shall be entitled to assume all the powers of the Board of Directors. Such committee(s) shall consist of at least three (3) members of the Association, one (1) of whom shall be a director. The committee of committees shall have such name or names as may be determined from time to time by the Board of Directors, and said committee(s) shall keep regular Minutes of their proceedings and report the same to the Board of Directors as required.

(g) To enter into and upon the Condominium Units when necessary and at as little inconvenience as practical in connection with the maintenance, care and preservation of Common Elements and Condominium owned personal property.

(h) To use and to expend the Assessment collected to maintain, care for and preserve the Condominium Units, the Common Elements, the Limited Common Elements over which the Association is obligated to maintain, care for and preserve, and the Condominium Property (other than the interiors of the Condominium Units which are to be maintained, cared for and preserved by the individual Condominium Unit Owners).

(i) To pay taxes and assessments levied and assessed against any real property the corporation might own and to pay for such equipment and tools, supplies and other personal property purchased for use in such maintained, care and preservation.

(j) The Association has an irrevocable right of access to enter each unit at any reasonable time when necessary for maintenance, repair or replacement of any common elements or of any portion of a unit to be maintained by the association pursuant to the declaration or as necessary to prevent damage to the common elements or to a unit or units.

(k) To repair and replace Common Element and Limited Common Element facilities, machinery and equipment.

(l) To insure and keep insured the Owners against loss from public liability and to carry such other insurance as the Board of Directors may deem advisable; and in the event of damage or destruction of property, real or personal, covered by such insurance, to use the proceeds for repairs and replacements, all in accordance with the provisions of the Declaration of Condominium.

(m) To review all complaints, grievances or claims of violations of the Declaration of Condominium, Exhibits thereto, the Condominium Act and the Rules and Regulations promulgated by the Association and to levy fines in accordance with the Condominium Act and establish a uniform procedure for determining whether such violations occurred and whether fines should be levied. Such procedure may be set forth in the Rules and Regulations promulgated by the Board of Directors. At a minimum, such Rules and Regulations shall provide that:

(1) The party against whom the fine is sought to be levied shall be afforded an opportunity for hearing, to be held before a committee of other unit owners, after reasonable notice of not less than fourteen (14) days and said notice shall include:

- a. A statement of the date, time and place of the hearing;
- b. A statement of the provisions of the declaration, association bylaws, or association rules which have allegedly been violated; and
- c. A short and plain statement of the matters asserted by the association.

(2) The party against whom the fine may be levied shall have an opportunity to respond, to present evidence, and to provide written and oral argument on all issues involved and shall have an opportunity at the hearing to review, challenge, and respond to any material considered by the Association.

(n) To collect delinquent assessments by suit or otherwise to abate nuisances and to enjoin or seek damages from Unit Owners for violations of the Declaration of Condominium, these By-Laws or Rules and Regulations adopted by the Board of Administration.

(o) To adopt hurricane shutter specifications which shall include color, styles, and other factors deemed relevant by the Board. All specifications adopted by the Board shall comply with the applicable building code. The Board shall not refuse to approve the installation or replacement of hurricane shutters conforming to the previously approved specifications by the Board. The installation, replacement and maintenance of such shutters in accordance with the procedures set forth herein shall not be deemed a material alteration to the Common Elements within the meaning of this section.

Section 17. Upon notice to the Unit Owners, the Board shall by duly adopted rule designate a specific location on the Condominium Property upon which all notices of Board meetings shall be posted.

ARTICLE SIX

Officers

Section 1. The principal officers of the Association shall be as follows:

President:	Cassandra Capecchi
Vice President:	Holly Baker
Secretary:	Louis Homsany

Section 2. The President shall preside at all membership meetings. He shall be a Director and shall, by virtue of his office, be Chairman of the Board of Directors. He shall present at each Annual Meeting of the Association an Annual Report of the work of the Association. He shall appoint all committees, temporary or permanent. He shall see to it that all books, reports and certificates, as required by law, are properly kept or filed. He shall be one of the officers who may sign the checks or drafts of the Association. He shall have such reasons as may be reasonably construed as belonging to the chief executive of any organization.

Section 3. The Vice President shall be a Director and shall, in the event of the absence or inability of the President to exercise his office, become acting President of the Association with all the rights, privileges and powers of said office.

Section 4. The Secretary shall:

- (a) Keep the Minutes and records of the Association in appropriate books.
- (b) File any certificate required by any statute, Federal or State.
- (c) Give and serve all notices to members of this Association.
- (d) Be the official custodian of the records and seal, if any, of this Association.
- (e) Be one of the officers required to sign the checks and drafts of the Association.
- (f) Present to the membership at any meetings any communications addressed to him as Secretary of the Association.
- (g) Submit to the Board of Directors any communications which shall be addressed to him as Secretary of the Association.
- (h) Attend to all correspondence of the Association and exercise all duties incident to the office of the Secretary.

Section 5. The Treasurer shall:

- (a) Have the care and custody of all monies belonging to the Association and shall be solely responsible for such monies or securities of the Association. He shall cause to be deposited in a regular business bank or trust company a sum not exceeding an amount authorized by the Board of Directors and the balance of the funds of the Association shall be deposited in a savings bank, except that the Board of Directors may cause such funds to be invested in such investments as shall be legal for a savings bank in the State of Florida.
- (b) Be one of the officers who shall be authorized to sign checks or drafts of the Association; no special fund may be set aside that shall make it unnecessary for the Treasurer to sign the checks issued upon it.
- (c) Render at stated periods as the Board of Directors shall determine a written account of the finances of the Association, and such report shall be physically affixed to the Minutes of the Board of Directors at such meeting.
- (d) All or a portion of the duties of the Treasurer may be fulfilled by a management company in the discretion of the Board of Directors.

Section 6. No officer of Director shall, for reason of his office, be entitled to receive any salary or compensation, but nothing herein shall be construed to prevent an officer of Director from receiving any compensation from the Association for duties other than as Director or officer.

ARTICLE SEVEN

Salaries

The Board of Directors shall hire and fix the compensation of any and all employees which they, in their discretion, may determine to be necessary in the conduct of the business of the Association. However, no member of the Board of Directors or an officer of the Association shall be paid any compensation for carrying out their duties.

ARTICLE EIGHT

Committees

All committees of this Association shall be appointed by the majority of the Board of Directors for whatever period of time is designated by said board of Directors.

ARTICLE NINE

Finances and Assessments

Section 1. Depositories: The funds of the Association shall be deposited in such banks and depositories as may be determined by the Board of Directors from time to time upon resolutions approved by the Board of Directors and shall be withdrawn only upon checks and demands for money signed by two (2) officers of the Association as may be designated by the Board of Directors. Obligations of the Association shall be signed by at least two (2) officers of the Association.

Section 2. Fiscal Year: The fiscal year for the Association shall begin on the first day of January each year; provided, however, that the Board of Directors is expressly authorized to change to a different fiscal year in accordance with the provisions and regulations from time to time prescribed by the Internal Revenue Code of the United States of America at such time as the Board of Directors deems it advisable.

Section 3. Determination of Assessment:

(a) The Board of Directors of the Association shall fix and determine from time to time the sum or sums necessary and adequate for the Common Expenses of the Condominium. Common Expenses shall include expenses for the operation, maintenance, repair or replacement of the Common Elements and the Limited Common Elements, costs of carrying out the powers and duties of the Association, all insurance premiums and expenses relating thereto, including fire insurance and extended coverage, and any other expenses designated as Common Expenses from time to time by the Declaration of the Association, or under the provisions of the Declaration of Condominium to which these By-Laws are attached. The Board of Directors is specifically empowered, on behalf of the Association to make and collect Assessments, and to lease, maintain, repair and replace the Common Elements and Limited Common Elements of the Condominium and recreation facilities. Funds for the payment of Common Expenses shall be assessed against the Unit Owners in the proportions and percentages of sharing Common Expenses as provided in the Declaration of Condominium. Said Assessments shall be payable monthly in advance unless otherwise ordered by the Board of Directors. Special Assessments, should such be required by the Board of Directors, shall be levied in the same manner as herein before proved for regular assessments, and shall be payable in the manner determined by the Board of Directors.

(b) When the Board of Directors has determined the amount of any Assessment, the Treasurer of the Association shall mail or present to each Unit Owner a statement of said Unit Owner's Assessment. All Assessments shall be payable to the Treasurer of the Association and, upon request, said Treasurer shall give a receipt for each payment made to him.

(c) The Board of Directors shall adopt an operating budget for each fiscal year.

Section 4. Application of Payments and Commingling of Funds: All funds shall be maintained separately in the Association's name. Reserve and operating funds of the Association shall not be commingled, except where such funds are used for investment purposes. All Assessment payments by a Unit Owner shall be applied as to interest, delinquencies, costs and attorneys' fees, other charges, expenses and advances, as provided herein and in the Declaration of Condominium, and general or Special Assessments, in such manner and amounts as the Board of Directors determines in its sole discretion. No managers or business entity required to be licensed or registered under Section 468.432, Florida Statutes, and no agent, employee, officer or director of the Association shall commingle any Association funds with the funds of any other condominium association or community association as defined in Section 468.431, Florida Statutes.

ARTICLE TEN

Minutes

Minutes of all meetings of the Association and the Board of Directors shall be kept in a businesslike manner and be made available for inspection by Unit Owners and Board members at all reasonable times.

ARTICLE ELEVEN

Compliance and Default

Section 1. If the Declaration of Condominium or these By-Laws so provides, the Association may levy a reasonable fine against a unit owner for failure of the unit owner to comply with any provision of the Declaration, these By-Laws or reasonable rule of the Association (other than the nonpayment of an Assessment). The Association, by direction of its Board of Directors, may notify the Unit Owner by written notice of said breach, transmitted by mail, and if such violation shall continue for a period of thirty (30) days from date of the notice, the Association, through its Board of Directors, shall have the right to treat such violation as an intentional, inexcusable and material breach of the Declaration, of the By-Laws and reasonable rules of the Association, and the Association may then, at its option, have the following elections:

- (a) An action at law to recover for its damage on behalf of the Association or on behalf of the other Unit Owners;
- (b) An action in equity for such equitable relief as may be necessary under the circumstances, including injunctive relief;
- (c) An action in equity to enforce performance on the part of the Unit Owner; or,
- (d) A fine which shall be imposed by the Board of Directors in an amount and manner set forth in the Rules and Regulations promulgated by the Board of Directors. Notwithstanding anything contained herein to the contrary, a fine shall not become a lien on the Unit.

Any remedy contained in the Declaration of Condominium, Exhibits thereto, the Condominium Act and/or the Rules and Regulations promulgated (including, but not limited to the foregoing) shall be cumulative and in addition to any and all other remedies provided by such documents or the law of the State of Florida.

Section 2. All Unit Owners shall be liable for the cost of any maintenance, repair or replacement rendered necessary by his act, neglect or carelessness, or by that of any member of his family, of his or their guests, employees, agents or lessees, but only to the extent that such expense is not met by the proceeds of insurance carried by the Association. Nothing herein contained, however, shall be construed so as to modify any waiver by an insurance company. Any rights or replacements required, as provided in this section, shall be charged to said Unit Owner as a specific item and the Association shall have a right to collect said charges.

Section 3. In any proceeding arising because of an alleged default by a Unit Owner, the Association shall be entitled to recover the costs of the proceeding and such reasonable attorney's fees as may be determined by the Court. In addition, the parties to a proceeding shall have any right to attorney's fees that may accrue under Section 718.303 and 718.125.

Section 4. The failure of the Association or of a Unit Owner to enforce any right, provision, covenant or condition which may be granted by the Condominium, documents shall not constitute a waiver of the right of the Association or Unit Owner to enforce such right, provisions covenant or condition of the future.

Section 5. In the event of any internal dispute arising from the operation of the Condominium among Unit Owners, the Association, and their agents and assigns, any party may apply for mandatory non-binding arbitration, in accordance with Section 718.1255, Florida Statutes. Venue for any such proceedings shall be in Duval County, Florida.

ARTICLE TWELVE

Indemnification

The Association shall indemnify every Director and every officer, their heirs, personal representatives and administrators, against all loss, cost and expense reasonably incurred by them in connection with any action, suite or proceedings to which they may be made a party by reason of their being or having been a Director and officer of the Association, including reasonable counsel fees to be approved by the Association, except as to matters wherein they shall be finally adjudged in such action, suit or proceeding to be liable for or guilty of gross negligence or willful misconduct. The foregoing rights shall be in addition to, and not exclusive of, all other rights to which such Director and officer may be entitled.

ARTICLE THIRTEEN

Liability Survives Termination of Membership

The termination of ownership in the Condominium shall not relieve or release any such former Owner or member from any liability or obligations incurred under or in any way connected with the Condominium during the period of such ownership and membership, or impair any rights or remedies which the Association may have against such former Owner and member arising out of or in any way connected with such ownership and membership and the covenants and obligations incident thereto.

ARTICLE FOURTEEN

Liens

Section 1. All liens against a Condominium Unit, other than for permitted mortgages, taxes or special Assessments, shall be satisfied or otherwise removed within thirty (30) days of the date the lien attaches. All taxes and Special Assessments upon a Condominium Unit shall be paid before becoming delinquent as provided in these Condominium documents or by law, whichever is sooner.

Section 2. A Unit Owner shall give notice to the Association of every lien upon his Unit, other than for permitted mortgages, taxes and Special Assessments, within five (5) days after the attaching of the lien.

Section 3. Unit Owners shall give notice to the Association of every suit or other proceedings which will or may affect title to his Unit or any part of the property, such notice to be given within five (5) days after the Unit Owner received notice thereof.

Section 4. Failure to comply with this Article Fourteen concerning liens will not affect the validity of any judicial sale.

Section 5. The Association may maintain a register of all permitted mortgages, and at the request of a mortgagee, the Association shall forward copies of all notices for unpaid Assessments or violations served upon a Unit Owner to said mortgagee. If a register is maintained, the Board of Directors of the Association may make such changes as it deems appropriate against the applicable Unit for supplying the information provided herein.

ARTICLE FIFTEEN

Amendments to the By-Laws

The By-Laws may be altered, amended or added to at any duly called meeting of the Unit Owners provided that:

- (a) Notice of the meeting shall contain a statement of the proposed amendment.
- (b) If the amendment has received the unanimous approval of the full Board of Directors, then it shall be approved upon the affirmative vote of the voting members casting a majority of the total votes of the Unit Owners present in person or by proxy at such meeting.
- (c) If the amendment has not been approved by the unanimous vote of the Board of Directors, then the amendment shall be approved by the affirmative vote of the voting members casting not less that two thirds (2/3) of the total votes of the Unit Owners present in person or by proxy at the meeting.

(d) Said amendment shall be recorded and certified as required by the Condominium Act. Notwithstanding anything above to the contrary, until one of the events in Article XXIII, Section 23.01 of the Declaration of Condominium occurs, these By-Laws may not be amended without a prior resolution requesting the said amendment from the Board of Directors.

(e) Except as otherwise provided in Sections 718.110(4) and (8), Florida Statutes, notwithstanding anything contained herein to the contrary, while the Developer is entitled to appoint a majority of the Board of Directors, the By-Laws may be amended by a majority of the Board of Directors, provided that such an Amendment shall not increase the proportion of common expenses nor decrease the ownership of Common Elements borne by the Unit Owners or change a Unit Owner's voting rights without the consent of the affected Unit Owners. Said Amendments need only be executed and acknowledged by the Association and the consent of the Unit Owners, the owner and holder of any lien encumbering a Unit in this Condominium, or any others, shall not be required.

ARTICLE SIXTEEN

Construction

Wherever the masculine singular form of the pronoun is used in these By-Laws, it shall be construed to mean the masculine, feminine or neuter, singular or plural, wherever the context so requires.

Should any of the covenants herein imposed be void or become unenforceable at law or in equity, the remaining provisions (or portions thereof) of this instruments shall nevertheless be and remain in full force and effect.

Headings are provided herein for convenience purposes only and shall not be construed for interpreting the meaning of any provisions of these By-Laws.

ARTICLE SEVENTEEN

Mandatory Arbitration

All internal disputes arising from the operation of the Condominium among the Unit Owners, Association and their guests and assigns, shall be subject to mandatory non-binding arbitration in accordance with Section 718.1255, Florida Statutes.

ARTICLE EIGHTEEN

Fidelity Bonds

The Association shall obtain and maintain adequate fidelity bonding of all persons who control or disburse funds of the Association. The insurance policy or fidelity bond must cover the maximum funds that will be in the custody of the Association or its management agent at any one time. As used in this section, the term "persons who control or disburse funds of the association" includes, but is not limited to, those individuals authorized to sign checks, and the president, secretary and treasurer of the Association. The Association shall bear the cost of bonding.

ARTICLE NINETEEN:

Certificates of Compliance

A Certificate of Compliance from a licensed electrical contractor or electrician may be accepted by the Association as evidence of compliance of the condominium units to the applicable fire and life safety code.

The foregoing was adopted as the By-Laws of GARDENS OF BRIDGEHAMPTON CONDOMINIUM ASSOCIATION, INC. at the first meeting of its Board of Directors.

Secretary

Approved:

President