

# KENSINGTON GARDENS UNIT 2B

A PART OF SECTION 27, TOWNSHIP 2 SOUTH, RANGE 28 EAST  
CITY OF JACKSONVILLE, DUVAL COUNTY, FLORIDA

### CAPTION

A part of Section 27, Township 2 South, Range 28 East, City of Jacksonville, Duval County, Florida, and being more particularly described as follows:

For a Point of Reference, commence at the corner common to Sections 22, 23, 26 and 27, of said Township and Range; thence South 01° 00' 47" East, along the dividing line between Section 26 and 27, a distance of 1332.20 feet, to a point on the Northerly line of a 40 foot right-of-way, as described and recorded in Official Records Volume 824, Page 384 of Public Records of said County; thence South 89° 51' 36" West, along last said line, 1911.57 feet to the Point of Beginning; thence continue South 89° 51' 36" West, along said Northerly line 300.03 feet; thence North 05° 47' 23" East, 352.85 feet; thence North 01° 49' 37" West, 180.36 feet to an intersection with a curve, concave Northerly and having a radius of 265.00 feet; thence Westerly along and around said curve, through a central angle of 07° 41' 38", an arc distance of 35.59 feet, said arc being subtended by a chord bearing and distance of North 79° 43' 26" West, 35.56 feet; thence North 01° 33' 00" East, 178.29 feet; thence North 28° 36' 16" West, 70.60 feet; thence North 13° 10' 30" West, 375.00 feet; thence South 84° 25' 48" East, 400.00 feet to a point on the Westerly line of Kensington Gardens Unit 2A, as recorded in Plat Book 44, Pages 41 through 41E of the Current Public Records of said County; thence South 15° 12' 57" West, along last said line 189.58 feet, to an angle point in said line; thence continue along said Westerly line of Kensington Gardens Unit 2A, South 06° 42' 50" East, 284.55 feet to a point on the Northerly right-of-way line St. Martins Drive South, said point being in a curve, said curve being concave Southeasterly and having a radius of 1075.00 feet; thence Southwesterly along the said Northerly right-of-way line of St. Martins Drive South along and around said curve, through a central angle of 00° 09' 32", an arc distance of 2.98 feet, said arc being subtended by a chord bearing and distance of South 71° 59' 59" West, 2.98 feet; thence continue along said Westerly line of Kensington Gardens Unit 2A, and a Southeasterly projection thereof, South 11° 40' 00" East, 255.33 feet; thence South 01° 35' 54" West, 387.08 feet to the Point of Beginning.

### ADOPTION AND DEDICATION

This is to certify that MJB - KENSINGTON ASSOCIATES, LTD., a Limited Partnership under the laws of the State of Florida, is the lawful owner of the lands described in the Caption hereon known as KENSINGTON GARDENS UNIT 2B, having caused the same to be surveyed and subdivided. This plat being made in accordance with said survey is hereby adopted as a true and correct plat of those lands. All rights-of-way, and easements for drainage, utilities, and sewers shown hereon are hereby irrevocably and without reservation dedicated to the City of Jacksonville, its successors and assigns.

The undersigned owner does hereby grant to the Jacksonville Electric Authority, and its successors, the J. E. A. easements shown hereon for use in its underground electric distribution system.

In witness whereof, MJB - KENSINGTON ASSOCIATES, LTD., has caused these presents to be signed by DAVID A. BINGEMANN, and with the authority of its General Partner, MJB - KENSINGTON, INC., in their names and with the corporate seal affixed. This 25th day of MARCH A.D., 1991.

Patricia Kelly  
Witness

Judith Barnett  
Witness

David A. Bingham  
DAVID A. BINGEMANN, PRESIDENT  
MJB - KENSINGTON, INC.  
AS GENERAL PARTNER OF  
MJB - KENSINGTON ASSOCIATES, LTD.

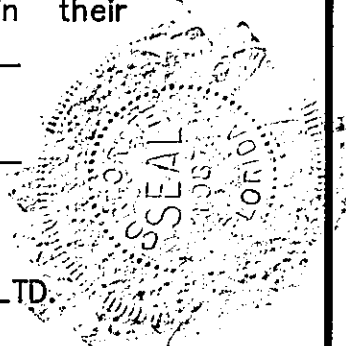

### STATE OF FLORIDA, COUNTY OF DUVAL

The foregoing instrument was acknowledged before me this 25th day of March A.D., 1991, by DAVID A. BINGEMANN, PRESIDENT, on behalf of MJB - KENSINGTON, INC., as General Partner of MJB - KENSINGTON ASSOCIATES, LTD., a Florida Limited Partnership.

My commission expires 9-29-91

Judith M. Johnson  
Notary Public State of Florida at Large

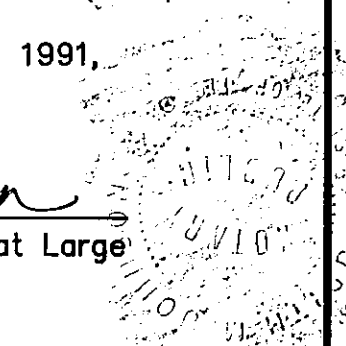

### DEDICATION OF MORTGAGEE

This is to certify that JACKSONVILLE FEDERAL SAVINGS BANK, being the mortgagee of the lands described in the foregoing Caption of this plat, does hereby join in and make itself a party to the the dedication of said lands and plat for the uses and purposes therein expressed by the owner thereof, and agrees that the mortgage shall be subordinated to said dedication.

In witness whereof, JACKSONVILLE FEDERAL SAVINGS BANK has caused these presents to be signed by its Senior Vice-President, by and with the authority of its Board of Directors, in its name and with its Corporate Seal affixed this 26th day of MARCH A.D., 1991.

Mary Jane Morgan  
Witness

William R. Thompson  
Witness

R. E. Brown  
R. E. BROWN  
SENIOR VICE PRESIDENT

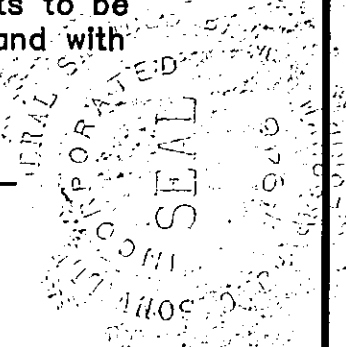

### STATE OF FLORIDA, COUNTY OF DUVAL

The foregoing instrument was acknowledged before me this 26th day of MARCH A.D., 1991, by R. E. Brown, Senior Vice President on behalf of JACKSONVILLE FEDERAL SAVINGS BANK

My commission expires 12/1/93

Mary Jane Morgan  
Notary Public State of Florida at Large

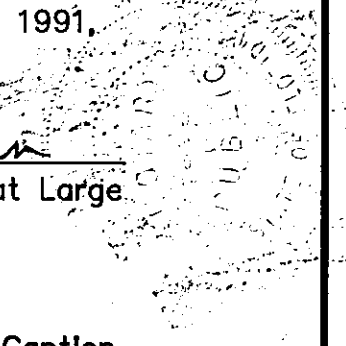

### DEDICATION OF MORTGAGEE

This is to certify that THOMAS D. BOROWY, being a mortgagee of the lands described in the foregoing Caption of this plat, does hereby join in and make himself a party to the dedication of said lands and plat for the uses and purposes therein expressed by the owner thereof, and agrees that the mortgage shall be subordinated to said dedication.

In witness whereof, THOMAS D. BOROWY, has caused these presents to be signed this 26th day of March A.D., 1991.

Linda C. Flad  
Witness

Michael W. Lauer  
Witness

Thomas D. Borowy  
THOMAS D. BOROWY

### STATE OF FLORIDA, COUNTY OF DUVAL

The foregoing instrument was acknowledged before me this 26th day of March A.D., 1991, by THOMAS D. BOROWY.

My commission expires November 16, 1991

Linda C. Flad  
Notary Public State of Florida at Large

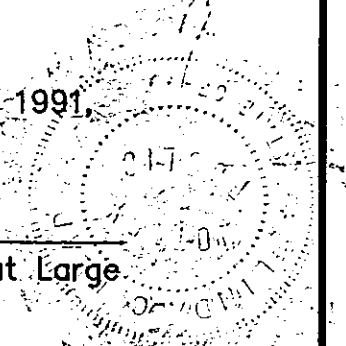

PREPARED BY  
SUNSHINE STATE SURVEYORS, INC.  
3131 ST. JOHNS BLUFF ROAD SOUTH  
JACKSONVILLE, FLORIDA 32216  
(904) 642-8550

### APPROVED

DATE: 4/16/91  
For Director of Public Works  
By: James E. Moore  
City Engineer

For General Council  
By: James A. Howard

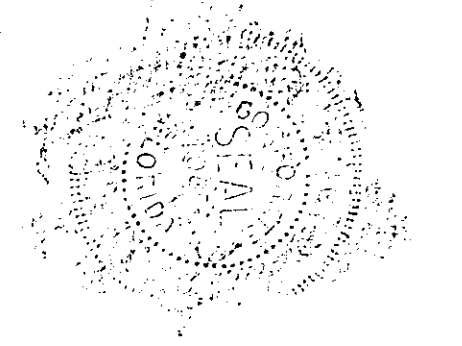
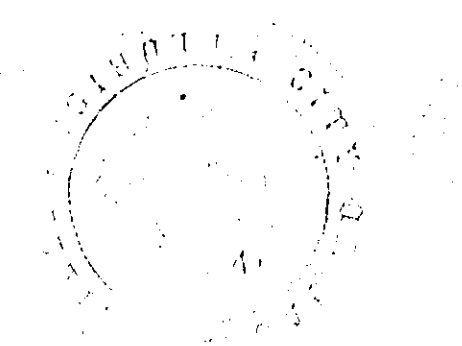

### APPROVED FOR RECORD

This is to certify that the above plat has been examined, accepted, and approved by the City of Jacksonville, Duval County, Florida, pursuant to City Ordinance No. 91-298-141 of said city, adopted by its Council, and accepted by its Mayor on this 20th day of May A.D., 1991.

James R. Kelly  
Mayor of the City of Jacksonville

Charles W. Kiedel  
Secretary to the Council, City of Jacksonville

### CLERK'S CERTIFICATE 91-0058932

This is to certify that this plat has been approved by the City Council of the City of Jacksonville, Florida, and submitted to me for recording, and is recorded in Plat Book 46, Pages 93, 93A of the Public Records of Duval County, Florida, this 13th day of June A.D., 1991.

Henry W. Cook  
Henry W. Cook, Clerk of the Circuit Court

Bridget G. DeVaughn  
Deputy Clerk

### DEVELOPER'S CERTIFICATE

This is to certify that MJB - KENSINGTON ASSOCIATES, LTD., has deposited with the City of Jacksonville sufficient collateral, in compliance with section 654.109 of the Municipal Code, in an amount equivalent to one hundred percent of all remaining costs for engineering and construction, including any required sidewalks, and costs of placing permanent control points, as guarantee that all required improvements will be completed in accordance with the plans and specifications approved by the City of Jacksonville.

Signed this 7th day of JUNE A.D., 1991.

David A. Bingham  
Director of Public Works

David A. Bingham  
DAVID A. BINGEMANN, PRESIDENT  
MJB - KENSINGTON, INC.  
AS GENERAL PARTNER OF  
MJB - KENSINGTON ASSOCIATES, LTD.

### SURVEYOR'S CERTIFICATE

This is to certify that the above plat is a correct representation of the lands surveyed, platted, and described in the above caption, that the survey was made under the undersigned's responsible direction and supervision, that the survey data complies with all of the requirements of Florida Statute 177, that the survey and legal description are accurate, and that the permanent reference monuments have been placed and permanent control points will be placed according to the laws of the State of Florida and the City of Jacksonville, Florida.

Signed and sealed this 22nd day of MARCH A.D., 1991.

W. Monroe Hazen, Jr.  
W. MONROE HAZEN, JR.  
REGISTERED LAND SURVEYOR No. 3398, FLORIDA

# KENSINGTON GARDENS UNIT 2B

A PART OF SECTION 27, TOWNSHIP 2 SOUTH, RANGE 28 EAST  
CITY OF JACKSONVILLE, DUVAL COUNTY, FLORIDA

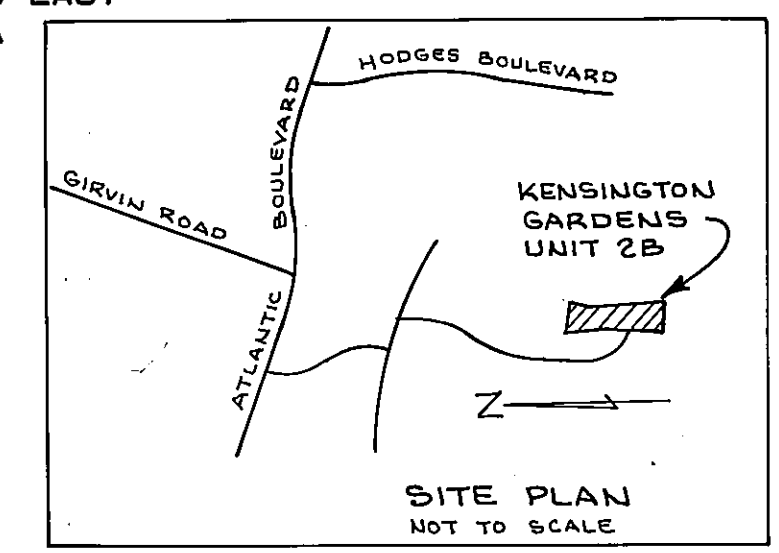
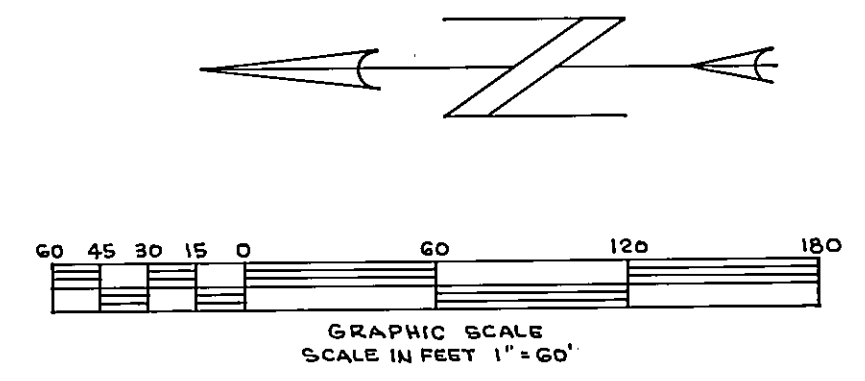

- 1.) ■ DENOTES PERMANENT REFERENCE MONUMENT.
- 2.) ○ DENOTES PERMANENT CONTROL POINT.
- 3.) BEARINGS SHOWN HEREON ARE BASED ON THE CENTERLINE OF THAT PORTION OF ATLANTIC BOULEVARD / STATE ROAD NO. 10, LYING BETWEEN P.T. STATION 290+91.5 AND P.C. STATION 322+77.15, ACCORDING TO D.O.T. RIGHT-OF-WAY MAPS, SECTION 72100-3176, BEING S 80° 55' 25" E.
- 4.) CI DENOTES TABLED CURVE DATA.
- 5.) CERTAIN EASEMENTS ARE FOR THE EXCLUSIVE USE OF JACKSONVILLE ELECTRIC AUTHORITY IN CONJUNCTION WITH ITS UNDERGROUND ELECTRIC DISTRIBUTION SYSTEM.
- 6.) EASEMENTS SHOWN HEREON ARE FOR DRAINAGE, UTILITIES, SEWERS AND CABLE TELEVISION, UNLESS NOTED OTHERWISE.
- 7.) NOTICE: THERE MAY BE ADDITIONAL RESTRICTIONS THAT ARE NOT RECORDED ON THIS PLAT THAT MAY BE FOUND IN THE PUBLIC RECORDS OF THIS COUNTY.
- 8.) O.R.V. DENOTES OFFICIAL RECORD VOLUME
- 9.) Δ = DELTA, R = RADIUS, A = ARC, C = CHORD, CB = CHORD BEARING

CURVE	DELTA	RADIUS	ARC	TANGENT	CHORD	CHORD BRG	CURVE	DELTA	RADIUS	ARC	TANGENT	CHORD	CHORD BRG
1	7°41'38"	265.00	35.59	17.82	35.56	N 79°43'26"W	25	4°54'20"	725.00	62.07	31.06	62.06	S 06°28'02"E
2	0°09'32"	1075.00	2.98	1.49	2.98	S 71°59'59"W	26	4°44'48"	725.00	60.06	30.05	60.04	S 11°17'36"E
3	1°40'32"	1050.00	30.70	15.35	30.70	S 70°55'46"W	27	2°38'06"	675.00	31.04	15.52	31.04	S 12°20'57"E
4	35°21'58"	240.00	148.14	76.52	145.80	S 87°46'29"W	28	5°16'13"	675.00	62.09	31.07	62.07	S 08°23'48"E
5	15°00'00"	250.00	65.45	32.91	65.26	N 04°10'00"W	29	1°05'41"	675.00	12.90	6.45	12.90	S 05°12'51"E
6	9°00'00"	700.00	109.96	55.09	109.84	N 09°10'00"W	30	86°02'54"	25.00	37.55	23.33	34.12	S 38°21'27"W
7	14°22'00"	700.00	175.52	88.22	175.06	N 06°29'00"W	31	25°43'55"	215.00	96.56	49.11	95.75	N 85°45'08"W
8	1°59'15"	1075.00	37.29	18.65	37.29	S 71°05'08"W	32	15°00'45"	265.00	69.44	34.92	69.24	N 88°55'22"E
9	105°14'30"	25.00	45.92	23.72	39.73	N 57°17'15"W	33	86°55'02"	25.00	37.92	23.69	34.39	S 55°07'31"E
10	2°46'20"	725.00	35.08	17.54	35.08	N 06°03'10"W	34	9°31'00"	225.00	37.37	18.73	37.33	S 06°54'30"E
11	5°32'52"	725.00	70.20	35.13	70.17	N 10°12'46"W	35	5°29'00"	225.00	21.53	10.77	21.52	S 00°35'30"W
12	0°40'48"	725.00	8.61	4.30	8.61	N 13°19'36"W	36	44°24'55"	25.00	19.38	10.21	18.90	S 25°32'28"W
13	1°35'50"	675.00	18.82	9.41	18.82	N 12°52'05"W	37	11°25'43"	45.00	8.98	4.50	8.96	S 42°02'04"W
14	5°33'35"	675.00	65.50	32.78	65.47	N 09°17'22"W	38	61°06'21"	45.00	47.99	26.56	45.75	S 05°45'02"W
15	3°02'51"	675.00	35.90	17.96	35.90	N 04°59'09"W	39	52°05'33"	45.00	40.91	21.99	39.52	S 50°49'55"E
16	46°32'06"	25.00	20.30	10.75	19.75	N 19°48'19"E	40	52°05'33"	45.00	40.91	21.99	39.52	N 77°04'32"E
17	20°33'02"	45.00	16.14	8.16	16.05	N 32°47'51"E	41	50°52'51"	45.00	39.96	21.41	38.66	N 25°35'20"E
18	59°37'58"	45.00	46.84	25.79	44.75	N 07°17'39"W	42	41°13'50"	45.00	32.38	16.93	31.69	N 20°28'00"W
19	49°52'46"	45.00	39.18	20.93	37.95	N 62°03'01"W	43	44°24'55"	25.00	19.38	10.21	18.90	N 18°52'28"W
20	46°23'48"	45.00	36.44	19.29	35.45	S 69°48'43"W	44	12°48'34"	275.00	61.48	30.87	61.35	N 03°04'17"W
21	44°56'46"	45.00	35.30	18.61	34.40	S 24°08'26"W	45	2°11'26"	275.00	10.51	5.26	10.51	N 10°34'17"W
22	47°21'42"	45.00	37.19	19.73	36.14	S 22°00'34"E	46	81°45'30"	25.00	35.67	21.64	32.72	N 29°12'45"E
23	42°30'41"	25.00	18.55	9.72	18.13	S 24°25'49"E	47	1°30'52"	1025.00	27.09	13.55	27.09	N 70°50'56"E
24	0°50'23"	725.00	10.63	5.31	10.63	S 03°35'40"E							

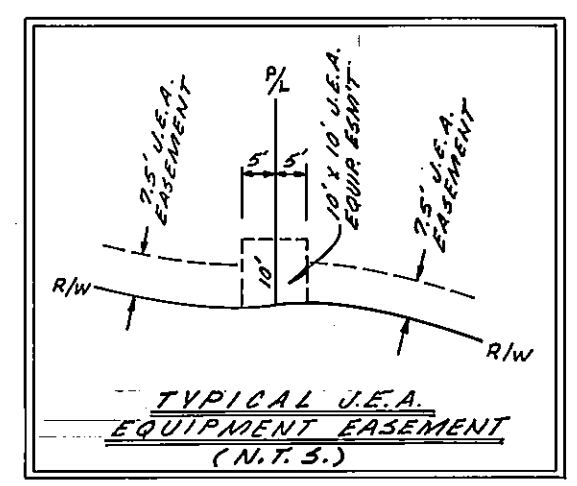
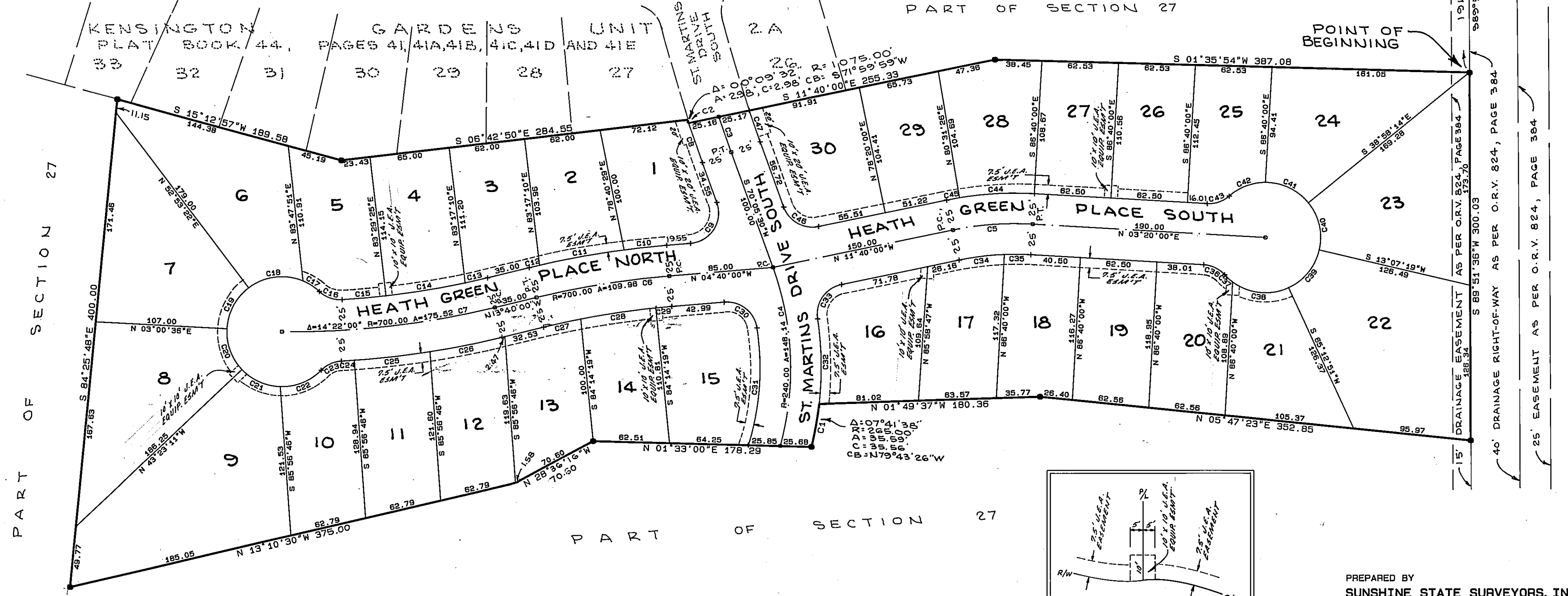

PREPARED BY  
**SUNSHINE STATE SURVEYORS, INC.**  
3131 ST. JOHNS BLUFF ROAD SOUTH  
JACKSONVILLE, FLORIDA 32216  
(904) 642-8550